

INSTINCT POWERPLAY™

---



CONFORMS TO SAFETY REQUIREMENTS  
CONFORME AUX EXIGENCES DE SÉCURITÉ  
ENTSPRICHT DEN SICHERHEITSANFORDERUNGEN  
CUMPLE CON LOS REQUISITOS DE SEGURIDAD

## REGISTER / ENREGISTRER / REGISTRA / REGISTRIERE

Registering your bike is the official way for us to welcome you into the Rocky Mountain family. It's also an important step in activating your bike's warranty. If you ever have an issue, we'll be able to handle your case efficiently and get you back riding as soon as possible. It's easy and only takes a few minutes.

**Register your bike:** [bikes.com/register](https://bikes.com/register)

L'enregistrement de votre vélo marque votre entrée officielle dans la famille Rocky Mountain, et c'est une étape importante pour en activer la garantie. Ainsi, en cas de problème, nous pourrions le régler efficacement pour vous faire remonter en selle aussitôt que possible. L'enregistrement est facile et ne prend que quelques minutes.

**Enregistrer votre vélo :** [bikes.com/register](https://bikes.com/register)

La procedura di registrazione della tua bicicletta è il modo ufficiale di accoglierti nella famiglia Rocky Mountain. È inoltre una tappa importante per attivare la garanzia della tua bicicletta. Nel caso in cui si verificasse un problema, potremo gestire il tuo caso in maniera efficiente e farti risalire in sella il più presto possibile. La procedura di registrazione è semplice e richiede solo alcuni minuti.

**Registra la tua bicicletta:** [bikes.com/register](https://bikes.com/register)

Wenn du dein Bike registrierst, können wir dich offiziell in der Rocky Mountain Familie willkommen heißen. Es ist auch ein wichtiger Schritt für die Aktivierung der Garantie deines Bikes. Solltest du irgendwann ein Problem haben, können wir deinen Fall effizient bearbeiten und dich schnellstmöglich wieder auf dein Bike bringen. Es ist einfach und dauert nur ein paar Minuten.

**Registrierte dein Bike:** [bikes.com/register](https://bikes.com/register)



<b>ENGLISH</b>	Register	2
	Quickstart	4
	Introduction	8
	Warning	9
	Getting to know your bike	11
	Geometry & Sizing	12
	Dropper Seatpost Fitment	16
	Specification and Dimensions	18
	Shock Bearing & Hardware	19
	Suspension Setup	20
	Critical Dimensions	24
	Parts List & Exploded View	26
	Images	32
	Rlding the bike	34
	Assistance Adjustment	36
	Battery	38
Rider Screens	42	
Reset	44	
Service	46	
General maintenance	48	
Warranty information	51	

<b>DEUTSCH</b>	Schnellstart	106
	Einleitung	110
	Warnungen	111
	Lerne dein bike kennen	113
	Geometrie & Größen	114
	Geometrietabelle	116
	Passung von vario-sattelstützen	118
	Spezifikationen und abmessungen	120
	Lagerbruchsens und hardware	121
	Suspensionsanordnung	123
	Wichtige Abmessungen	126
	Explosionszeichnung Teilleiste	128
	Blider	134
	Fahrt	136
	Das bike fahren	137
	Einstellung der unterstützung	138
Akku	140	
Fahrerbildschirme	144	
Zurücksetzen	146	
Service	148	
Wartung	150	
Garantieinformationen	153	

<b>FRANÇAIS</b>	Guide de démarrage rapide	55
	Introduction	59
	Avertissements	60
	Survol de votre vélo	62
	Géométrie et taille	63
	Ajustement des tiges de selle télescopiques	67
	Spécifications et dimensions	69
	Quincaillerie	70
	Configuration suspension	72
	Guide des dimensions	75
	Vue explosé et pièces	77
	Images	83
	Utilisation du vélo	85
	Réglage de l'assistance	87
	Batterie	89
	Écrans du riders	93
Réinitialisation	95	
Entretien	97	
Service	98	
Entretien générale	99	
Garantie	102	

<b>ITALIANO</b>	Avvio rapido	157
	Introduzione	161
	Avertimenti	162
	Conoscere la tua bicicletta	164
	Gemetria e dimensioni	165
	Montaggio reggiselle telescopico	169
	Specifiche e dimensioni	171
	Shock Bearing and Hardware	172
	Configurazione delle sospensioni	174
	Dimensioni critiche	177
	Vista Explosa & Elenco parti	179
	Immagini	185
	Uso della bicicletta	187
	Regolazione assistenza	189
	Batteria	191
	Schermate di guida	195
Reimpostazione	197	
Interventi	199	
Servizio	200	
Manutenzione generale	201	
Garanzia	203	



## QUICKSTART

### Connect the Jumbotron

In order to comply with shipping regulations, the power source must be disconnected in transit. Locate and connect the main power (battery) source to the motor.

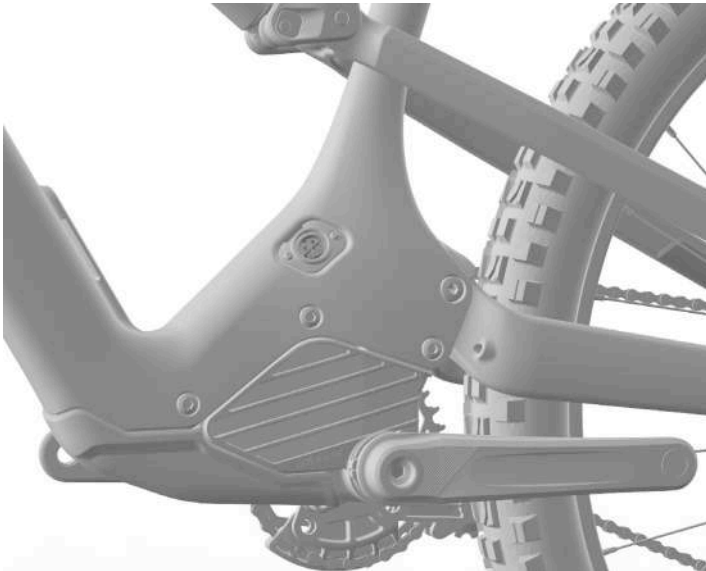

## QUICKSTART

### Charge the battery

The battery must be shipped with approximately 50% charge. Please charge your bike to 100% before its first use. NOTE THE ORIENTATION OF THE CONNECTOR. Failure to align the connector can result in permanent damage.



## QUICKSTART

### Turn the bike on

Hold the power button on the Jumbotron for 2 seconds to power up the bike.



### Set up Your Bike

Upon its first activation, the bike will prompt the rider to initialize its settings. This step can be skipped, and you can ride it immediately by pressing ⚡. You can re-enter the main menu any time by holding ⚡.

### Remote & Jumbotron buttons

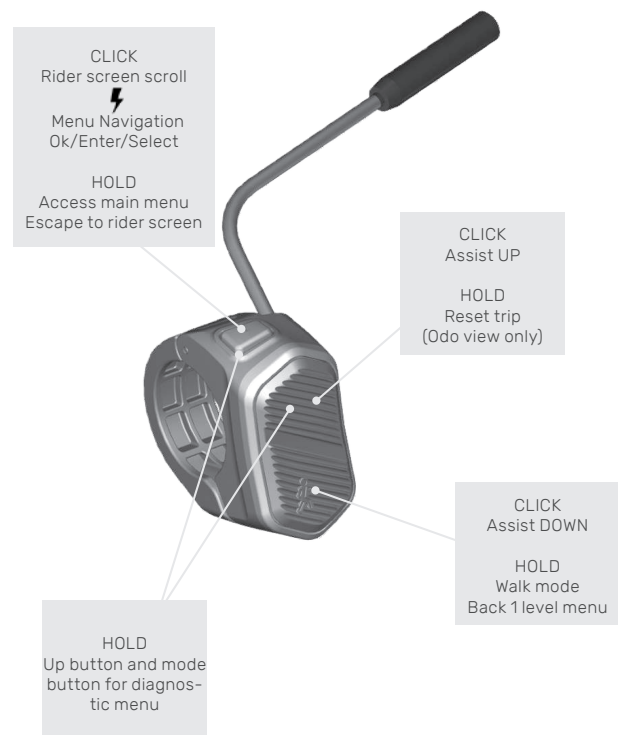
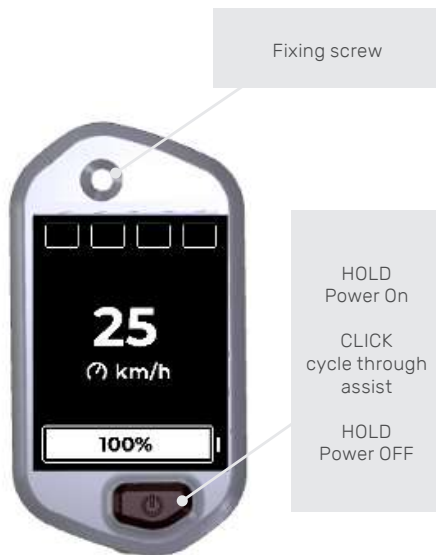

## QUICKSTART



### How to Access Menu

You can enter the main menu any time by holding . To escape, select the BACK icon, or hold .

### How to Access Diagnostics

You can enter the diagnostic menu any time by holding both  and the assist UP button. To escape, select the BACK icon, or hold .



### How to Navigate Menu

Within a menu, you can navigate using the remote assist UP and assist DOWN buttons; use the  button to confirm commands. To escape, select the BACK icon, or hold .

### Calibrate the system

The Dymate S4 Lite drive system uses chain tension to measure rider input. It is recommended to calibrate the system before its first use, and then after roughly 75kms (45 miles). Hold the  to enter the main menu, select calibration and follow the prompts.

### How to Navigate Menu

Within a menu, you can navigate using the remote assist UP and assist DOWN buttons; use the  button to confirm commands. To escape, select the BACK icon, or hold .

## KID MODE

All Powerplay™ electric bikes are equipped with a power and speed limiter, as well as a child lock. Please see the RIDING THE BIKE section of this manual for more information on how to activate and adjust these settings.

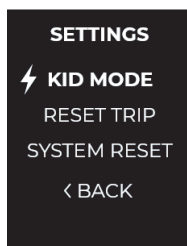

### Read the Manual

Finally, and most importantly, read the manual included with the bicycle, or find it online at [support.bikes.com](http://support.bikes.com).

## INTRODUCTION

Your Instinct, electrified. The Instinct Powerplay™ SL packs a punch in a lightweight package. Powered by our all new Dyname S4 Lite drive system, we've designed a bike that rides like a trail bike but with the power to explore further than ever before. Built around our mid-high pivot suspension system, the frame has seen a complete overhaul with updated geometry, and suspension kinematics, improving ride feel and offering plenty of frame adjustments.

This manual contains important safety, maintenance, and user information. Please make sure to read it carefully and understand it thoroughly before your first ride on your new Rocky Mountain Instinct Powerplay™ SL bicycle. This material applies only to the specific platform you have chosen and should be used in conjunction with your Rocky Mountain Owner's Manual, which is included with your bike. Please read the Owner's Manual before your first ride. If you do not have a copy of the Owner's Manual, you can get it from your nearest authorized Rocky Mountain dealer or online, on your bike model's product page.

## SHREDIQUETTE

### Users

Always be courteous to other trail users. Use extra caution around domestic animals, such as dogs and horses. Give other trail users right-of-way in all situations, during both climbing and descending.

The Instinct Powerplay™ SL models are designed for trail riding in approved areas. The intended use is for riding more difficult terrain that includes moderate jumps and technical features. These models are not designed for extreme forms of riding that include extreme jumping; or downhill grades on rough trails at speeds more than 40 km/h (25 mph); or a combination thereof. These models are not intended for large drop-offs, jumps, or launches from wooden structures, or features that require hard landings and harsh obstacles.

### Trail

Only ride your Instinct Powerplay™ SL on trails and paths sanctioned for bicycle and Class 1 e-bike use. Follow all local laws and regulations. As for all trail users, care should be taken to avoid impacts on the trail or environment. Do not skid on or modify trails.

### Public Roads

Before riding your Rocky Mountain Instinct Powerplay™ SL bicycle please inform yourself of all applicable legal requirements and regulations in your country, state, or province. There may be restrictions on riding your Powerplay™ bicycle on public roads, cycling paths, and/or trails. There may also be applicable helmet and light requirements, age restrictions or license or insurance requirements. Rocky Mountain does not, and will not, make any promise, representation, or warranty regarding the use of your Powerplay™ bicycle. As laws and regulations regarding electric bicycles vary by country and/or state and province and are constantly changing, please make sure to obtain the latest information. You should also regularly see your Authorized Rocky Mountain Bicycles Dealer for updated information.

### Safety and Visibility

Before riding your Rocky Mountain Instinct Powerplay™ SL bicycle, please ensure that all visibility and safety equipment included with your Powerplay bicycle is installed to ensure compliance with legal requirements and regulations in your country, state, or province.

If a bell is included with your Rocky Mountain Instinct Powerplay™ SL bicycle (France, UK, Australia & New Zealand), it is mandatory to have it installed on your Powerplay™ bicycle before use.

## WARNINGS

### Power

Your Instinct Powerplay™ SL bicycle features a powerful pedal assist when force is applied to the pedals. Familiarize yourself with your bike's ride and pedal assist characteristics in safe and flat surroundings before riding it off road.

### Instant start

Your Instinct Powerplay™ SL bicycle features "Instant Start" technology, which uses a sophisticated torque sensing circuit to deliver smooth, instant, natural feeling power. This circuit is very sensitive, so care must be taken to ensure the bike does not accelerate from a stop in an unexpected or uncontrolled manner.

### Use caution on trails

Your Instinct Powerplay™ SL bicycle accelerates more quickly and handles differently than traditional non-assist bicycles. Use appropriate caution on trails and be aware of your bike's unique handling and acceleration characteristics.

### Keep your fingers away

Do not place your fingers or tools near the Drive unit. Maintenance and repair of the drive unit should only be performed by an Authorized Rocky Mountain Service Centre.



### Do not modify

Do not modify the Instinct Powerplay™ SL Drive unit or any components directly connected to the drive unit. Maintenance and repair of the drive unit should only be performed by an Authorized Rocky Mountain Service Centre. Any attempt to modify the Instinct Powerplay™ SL Drive unit may result in serious personal injury or death and will immediately void the bicycle's warranty.

## WARNINGS

Do not attach a child carrier, trailer, or similar accessory to a composite or carbon fiber part or component, either directly or indirectly. For example, do not attach a triangle to a rear axle when the rear triangle is made of composite or carbon fiber. Likewise, do not attach a trailer to a composite or carbon seatpost or a child carrier to a composite or carbon fork. Either may potentially apply unusual forces on your bicycle frame or component which could result in damage and cause a complete failure, with the risk of serious injury or death. If you have previously attached an accessory to a composite or carbon fiber part or component, do not ride until you have had your authorized Rocky Mountain Dealer conduct a careful safety inspection. Before riding with kids on your bicycle, please inform yourself of all applicable legal requirements and regulations in your country and state or province. There may be restrictions on riding your bicycle with certain or any accessory(ies). This is especially true for electric and pedal-assist bicycles.

### WARNING 1

As with all mechanical components, EPAC is subjected to wear and high stresses. Different materials and components may react to wear or stress fatigue in different ways. If the design life of a component has been exceeded, it may suddenly fail possibly causing injuries to the rider. Any form of crack scratches or change of colouring in highly stressed areas indicate that the life of the component has been reached and it should be replaced.

### WARNING 2

For composite components impact damage may be invisible to the user, the manufacturer shall explain the consequences of impact damage and that in the event of an impact; composite components should either be returned to the manufacturer for inspection or destroyed and replaced.

### WARNING 3

Do not expose the bicycle to prolonged direct sunlight or excessive heat, such as inside a parked car or near a heat source such as a radiator. Excessive heat may degrade the material properties of components and parts such as batteries, composite parts such as handlebars, crankarms, and other items made of composite materials, and various plastics components that contribute to the integrity of the complete bicycles.

### WARNING 4

The maximum permissible total payload (rider plus luggage, and the empty weight of the EPAC) is 130kg for the Carbon Instinct Powerplay SL, and 140Kg for the Alloy version.

### WARNING 5

Failure to follow the warnings in this section may result in damage to the components on your bicycle and will void your warranty, but, most importantly, may result in serious personal injury or death. If your bicycle exhibits any signs of damage, do not use it and immediately bring it to your Rocky Mountain Bicycles Retailer for inspection.

### WARNING 6

In the event of a crash or improper assembly, the handlebar and handlebar controls may be compromised and the rider's response to steering and braking safely may be adversely affected.

### WARNING 7

Never inflate a tire beyond the lower of the two values of the maximum pressure marked on the tire's sidewall and the maximum pressure marked on the rim that the tire is installed on. Exceeding the recommended maximum pressure may blow the tire off the rim, which could cause damage to the bike and injury to the rider and bystanders.

## GETTING TO KNOW YOUR BIKE



### TECHNICAL DETAILS

- The Instinct Powerplay™ SL is built around our all new Dyname S4 Lite drive system. Featuring a completely new frame design with new tube profiles, the Instinct Powerplay SL's frame is lighter, and added adjustability compared to it's predecessor for a more optimized rider fit.
- The new Dyname S4 Lite drive unit will have you racing up the climbs with up to 65Nm of peak torque, and up to 550 watts of peak power output. At a cadence of 80 RPM, the motor can offer up to 500 Watts of power, whenever you need it.
- Built around our patented external torque sensor, the Dyname S4 Lite system reads the tension that is being applied directly to the chain and removes unwanted lag time to give an instantaneous and natural response when the power is applied. Equipped with our all new light and slim 480 Wh battery, the new Dyname S4 Lite system offers over 90% of the range and vertical that our Dyname 4.0 system offers (testing done in Ludicrous, Boost +2).
- The Dyname S4 Lite is equipped with the Jumbotron display screen, seamlessly integrated into the top tube to show all key data and information in a convenient, easy to see location. The screens can be navigated through using the handlebar remote or the buttons on the Jumbotron itself.
- Revised Mid-High Pivot kinematics feature sensitivity paired with increased support throughout the travel, with a goal of increasing support and comfort on those short and long rides.
- Offered in a wide range of frame and wheel sizes. The XS frame is equipped with 27.5" front and rear wheels. The SM-MD-LG-XL frames are equipped with 29" front and rear wheels. These sizes are also mullet compatible with the use of a specific MX suspension linkage.
- The RIDE-4™ adjustment system allows riders to quickly fine-tune their geometry with a single Allen key.
- All frames are equipped with reach adjust headsets to fine tune the reach. Installed on the frame is a 0mm / neutral headset. In the small parts box added with every frameset and complete bicycle, there is an additional set of 5mm headset cups that can be used to make reach adjustments.
- Sealed bearings at the shock eyelet dramatically improve shock sensitivity (aftermarket shock compatible) while bearing shields throughout the frame help prevent contamination from gnarly trail conditions or post-ride wash stations.
- Our Smoothlink suspension features common, easy to service bearings paired with durable pivot design.
- Fully enclosed internal routing on our carbon and alloy models, thanks to our integrated cable guide sleeve, allow for easy cable and hose installation, including moto-style brake setups.
- The frames have extensive rubber protection to both reduce noise and prevent contact abrasion.

## GEOMETRY & SIZING

The Instinct Powerplay™ SL is a size-specific frame design that features many details that improve the fit and geometry for each rider.

### Wheel size

- The XS frame is equipped with 27.5" wheels front and back.
- The XS frame is not compatible with 29" wheels, or MX compatible.
- The SM, MD, LG, and XL are equipped with 29" wheels front and back.
- SM, MD, LG, and XL are mullet/MX compatible by swapping out the suspension linkage.

### Reach-Adjust Headsets

All frames are equipped with reach adjust headsets to fine tune the reach. Installed on the frame is a 0mm / neutral headset. In the small parts box added with every frameset and complete bicycle, there is an additional set of 5mm headset cups that can be used to make reach adjustments. When reviewing the geometry chart with the 5mm offset cups installed, simply add, or subtract 5mm from the Reach, Top Tube Length, and Wheelbase measurements to match the orientation of the cups. For installation instructions, please see the Frame Features section.

Carbon headset 0mm



Carbon headset 5mm



Alloy headset 0mm



Alloy headset 5mm



### Frame Sizing

This chart is a rough guide only. Rider proportions, riding style, and personal preferences all factor in choosing the correct bike size. Generally, shorter reach bikes tend to have a more dynamic, lively feel. Longer bikes tend to have a more stable, muted feel. Rocky Mountain always recommends test riding and professional bike fitting at an authorized dealer.

CM	147.5	150	152.5	152.5	155	157.5	160	162.5	165	167.5	170	172.5	175	177.5	180	183	185.5	188	190.5	193	195.5	198		
FT-IN	4'7"	4'8"	4'9"	5'0"	5'1"	5'2"	5'3"	5'4"	5'5"	5'6"	5'7"	5'8"	5'9"	5'10"	5'11"	6'	6'1"	6'2"	6'3"	6'4"	6'5"	6'6"		
	XS				SM				MD				LG				XL							
XS	[Red bar spanning from 147.5 to 157.5 cm]																							
SM	[Red bar spanning from 152.5 to 170 cm]																							
MD	[Red bar spanning from 160 to 177.5 cm]																							
LG	[Red bar spanning from 170 to 188 cm]																							
XL	[Red bar spanning from 180 to 198 cm]																							

## GEOMETRY & SIZING

### RIDE-4 Adjustment

The RIDE-4™ adjustment system allows riders to quickly fine-tune their geometry with a single 5-mm Allen key. Four configurations are possible thanks to a pair of rotating chips. Please see the geometry chart for how each position affects the geometry. For adjustment instructions, please see the Frame Features section.

#### READY FOR ANY TRAIL

The RIDE-4™ adjustment system allows you to quickly fine-tune your geometry and suspension with a single 5-mm Allen key.

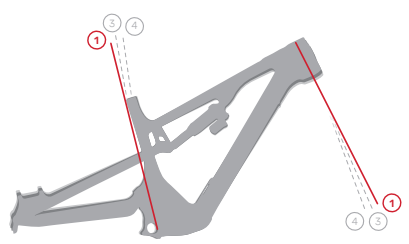
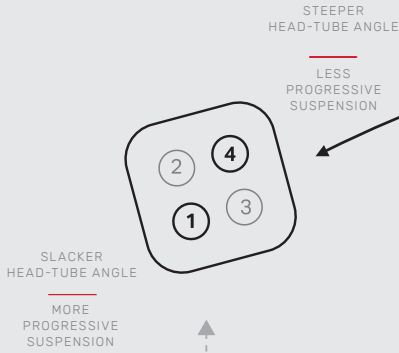

#### Position 1



The lower bottom bracket and progressive suspension increase stability at higher speeds. Recommended for more aggressive trail riding

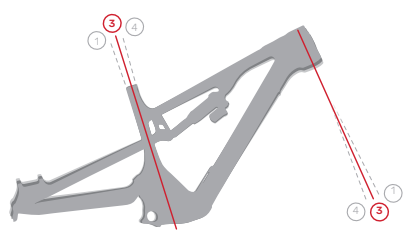

#### Position 3



This position offers a balanced blend of geometry and suspension performance to cater to a wide variety of trails

#### Position 4



The higher bottom bracket and linear suspension allow for better pedal clearance, a more supportive initial suspension rate, and a position on the bike better suited for climbing.

## GEOMETRY & SIZING

FRAME SIZE		XS	SM	MD	LG	XL
<b>Wheel size</b>		<b>27.5</b>			<b>29</b>	
Head Tube Angle (deg)		63.5	63.5	63.5	63.5	63.5
Seat Tube Angle (deg)		76.4	77.0	76.5	76.5	76.5
Seat Tube Length (mm)		355.0	365.0	410.0	440.0	470.0
Top Tube Length (mm)		542.0	567.0	599.0	627.0	659.0
Head Tube Length (mm)		105.0	105.0	110.0	125.0	135.0
Rear Center (mm)	Position 1 - Slack	433.0	442.0	442.0	452.0	452.0
Bottom Bracket Drop (mm)		24.2	38.8	38.8	38.7	38.8
Standover Height (mm)		775.0	785.0	809.0	808.0	807.0
Wheelbase (mm)		1157.0	1205.0	1232.0	1274.0	1308.0
Reach (mm)		399.0	425.0	450.0	475.0	505.0
Stack (mm)		590.0	618.0	622.0	636.0	645.0
Head Tube Angle (deg)		63.7	63.7	63.7	63.7	63.7
Seat Tube Angle (deg)		76.6	77.2	76.7	76.7	76.7
Seat Tube Length (mm)		355.0	365.0	410.0	440.0	470.0
Top Tube Length (mm)		541.0	567.0	599.0	627.0	659.0
Head Tube Length (mm)		105.0	105.0	110.0	125.0	135.0
Rear Center (mm)	Position 2	430.0	440.0	440.0	450.0	450.0
Bottom Bracket Drop (mm)		17.0	32.0	32.0	32.0	32.0
Standover Height (mm)		780.0	790.0	813.0	813.0	813.0
Wheelbase (mm)		1154.0	1203.0	1230.0	1272.0	1306.0
Reach (mm)		405.0	430.0	455.0	480.0	510.0
Stack (mm)		586.0	614.0	618.0	632.0	641.0

## GEOMETRY & SIZING

FRAME SIZE		XS	SM	MD	LG	XL
Wheel size		27.5			29	
Head Tube Angle (deg)		64.0	64.0	64.0	64.0	64.0
Seat Tube Angle (deg)		77.0	77.5	77.0	77.0	77.0
Seat Tube Length (mm)		355.0	365.0	410.0	440.0	470.0
Top Tube Length (mm)		540.0	566.0	598.0	626.0	658.0
Head Tube Length (mm)		105.0	105.0	110.0	125.0	135.0
Rear Center (mm)	Position 3 - Neutral	430.0	440.0	440.0	450.0	450.0
Bottom Bracket Drop (mm)		17.0	32.0	32.0	32.0	32.0
Standover Height (mm)		780.0	790.0	813.0	813.0	813.0
Wheelbase (mm)		1154.0	1203.0	1230.0	1272.0	1306.0
Reach (mm)		405.0	430.0	455.0	480.0	510.0
Stack (mm)		586.0	614.0	618.0	632.0	641.0
<hr/>						
Head Tube Angle (deg)		64.2	64.2	64.2	64.2	64.2
Seat Tube Angle (deg)		77.2	77.7	77.2	77.2	77.2
Seat Tube Length (mm)		355.0	365.0	410.0	440.0	470.0
Top Tube Length (mm)		540.0	566.0	597.0	625.0	657.0
Head Tube Length (mm)		105.0	105.0	110.0	125.0	135.0
Rear Center (mm)	Position 3 - Neutral	429.0	439.0	439.0	449.0	449.0
Bottom Bracket Drop (mm)		14.1	29.2	29.1	29.1	29.0
Standover Height (mm)		782.0	792.0	816.0	815.0	815.0
Wheelbase (mm)		1153.0	1202.0	1229.0	1271.0	1305.0
Reach (mm)		407.0	432.0	457.0	482.0	512.0
Stack (mm)		585.0	612.0	617.0	630.0	639.0

## DROPPER SEATPOST FITMENT

Dropper seatposts have play an important role in bike fit and comfort. Below you will find the critical dimensions and measurements that will guide you in the OEM post configuration as well as some of the possible options if an aftermarket dropper seatpost is installed.

The chart shows seatpost fitment with the seatpost travel fully extended. This allows you to determine what the lowest or highest position your seatpost can be set at for the correct height in a seated pedalling position. The chart will also help guide you in determining the size seatpost to install if the OEM one isn't the desired size. Please note that the dimension listed is from the center of the BB to the top of the OEM saddle. Crankset length can influence the seated fit and should also be considered if that component is changed.

How to use the chart:

1. Measure your current saddle height from the center of the bottom bracket to the top of the saddle right above the seatpost.
2. Choose your desired post model and amount of post travel/drop and frame.
3. Ensure that your measurement falls between the minimum and maximum insertion length listed in the chart.

Example: I measured 795mm on my current bike. If I choose a OneUp V3, 210mm travel option, on a LG Carbon frame, I can see that I can fit this combination of post travel and frame size as the minimum and maximum measurements possible are 725mm to 855mm.

POST MODEL	POST TRAVEL	FRAME SIZE	CARBON					ALLOY				
			XS	SM	MD	LG	XL	XS	SM	MD	LG	XL
X Fusion Manic		Seat Tube Length	355	365	410	440	470	355	365	410	440	470
		Minimum Insertion	100	100	100	100	100	100	100	100	100	100
		Maximum Insertion	220	230	275	305	335	220	230	275	305	335
	125	Minimum saddle height	541	547	592	622	652	541	547	592	622	652
	125	Maximum saddle height	623	633	678	708	738	623	633	678	708	738
	150	Minimum saddle height	605	605	617	647	677	605	605	617	647	677
	150	Maximum saddle height	687	697	742	772	802	687	697	742	772	802
	170	Minimum saddle height	649	649	649	667	697	649	649	649	667	697
	170	Maximum saddle height	701	711	756	786	816	701	711	756	786	816
	190	Minimum saddle height	702	702	702	702	717	702	702	702	702	717
190	Maximum saddle height	734	744	789	819	849	734	744	789	819	849	
2025 Fox Transfer	120	Minimum saddle height	556	566	611	641	671	556	566	611	641	671
	120	Maximum saddle height	646	656	701	731	761	646	656	701	731	761
	150	Minimum saddle height	619	619	642	672	702	619	619	642	672	702
	150	Maximum saddle height	711	721	766	796	826	711	721	766	796	826
	180	Minimum saddle height	684	684	684	701	731	684	684	684	701	731
	180	Maximum saddle height	776	786	831	861	891	776	786	831	861	891
	210	Minimum saddle height	749	749	749	749	761	749	749	749	749	761
	210	Maximum saddle height	841	851	896	926	956	841	851	896	926	956
	240	Minimum saddle height	819	819	819	819	819	819	819	819	819	819
	240	Maximum saddle height	911	921	966	996	1026	911	921	966	996	1026

POST MODEL	POST TRAVEL	FRAME SIZE	CARBON					ALLOY				
			XS	SM	MD	LG	XL	XS	SM	MD	LG	XL
<b>2020-2024 Race Face Turbine R Fox Transfer</b>	125	Minimum saddle height	572	573	618	648	678	572	573	618	648	678
	125	Maximum saddle height	664	674	719	749	779	664	674	719	749	779
	150	Minimum saddle height	626	626	643	673	703	626	626	643	673	703
	150	Maximum saddle height	718	728	773	803	833	718	728	773	803	833
	175	Minimum saddle height	683	683	683	698	728	683	683	683	698	728
	175	Minimum saddle height	775	785	830	860	890	775	785	830	860	890
	200	Minimum saddle height	739	739	739	739	754	739	739	739	739	754
	200	Maximum saddle height	781	791	836	866	896	781	791	836	866	896
<b>OneUp V3 Dropper</b> *Travel can be reduced by up to 20mm, in 10 mm increments.	120	Seat Tube Length	550	560	605	635	665	550	560	605	635	665
	120	Minimum Insertion	650	660	705	735	765	650	660	705	735	765
	150	Maximum Insertion	595	595	635	665	695	595	595	635	665	695
	150	Minimum saddle height	700	710	755	785	815	700	710	755	785	815
	180	Maximum saddle height	660	660	665	695	725	660	660	665	695	725
	180	Minimum saddle height	750	760	805	835	865	750	760	805	835	865
	210	Maximum saddle height	725	725	725	725	755	725	725	725	725	755
	210	Minimum saddle height	800	810	855	885	915	800	810	855	885	915
<b>Reverb AXS</b> *Min post insertion is 80mm, however frame requires 100mm	125	Minimum saddle height	593	600	645	675	705	593	600	645	675	705
	125	Maximum saddle height	710	720	765	795	825	710	720	765	795	825
	150	Minimum saddle height	643	643	670	700	730	643	643	670	700	730
	150	Maximum saddle height	760	770	815	845	875	760	770	815	845	875
	170	Minimum saddle height	683	683	690	720	750	683	683	690	720	750
	170	Maximum saddle height	800	810	855	885	915	800	810	855	885	915

## SPECIFICATIONS AND DIMENSIONS

### Reach-Adjust Headset

All frames are equipped with reach adjust headsets to fine tune the reach. Installed on the frame is a 0mm / neutral headset. In the small parts box added with every frameset and complete bicycle, there is an additional set of 5mm headset cups that can be used to make reach adjustments.

The Carbon Instinct Powerplay™ SL frame uses drop-in style, oval headset cups. No tools are required to remove and install the cups in the frame. Cup alignment is automatically achieved due to the keyed, oval shape of the cups and headtube. The cups feature an integrated o-ring around the outside of the cup to keep them secured in the frame and reduce movement that can lead to noise. The headsets for the carbon frames are manufactured by FSA and are the No.85-1 model. They use standard FSA assembly parts such as bearings and races to ensure that replacing wear items are a painless process.

The Alloy Instinct Powerplay™ SL frame uses press-in style, oversized headset cups. Specialized headset installation tools are required to remove and install the cups in the frame. Cup alignment must be carefully managed to achieve proper alignment due to the non-keyed shape of the cups and headtube. The cups feature an alignment mark on the outside face to align them in the frame. Aligning a long straight edge ruler along this mark and the length of the top tube (upper cup) or downtube (lower cup) is the easiest way to ensure proper cup alignment. The headsets for the alloy frames are manufactured by FSA and are the HS-RM-01 model. They use standard FSA assembly parts such as bearings and races to ensure that replacing wear items are a painless process.

### Instinct Powerplay SL Carbon Headset

QTY	ITEM	PART NUMBER	DESCRIPTION
N/A	Headset	14100078000013	FSA Part Number   No.85-1 0mm Offset Headset, complete
N/A	Headset	1194001	RMB Part Number   No.85-1 0mm Offset Headset, complete
1	Headset Cup Set	141-0079000011	FSA Part Number   No.85-1 5mm Offset cups only
1	Headset Cup Set	1194002	RMB Part Number   No.85-1 5mm Offset cups inc. O-rings
1	Rubber O-Ring	160-7042	FSA Top Cap Inner Rubber O-Ring
1	Top Cap	161-4430	FSA 5.3mm Top Cap inc. rubber seal
1	Split Race	160-7626	FSA 1 1/8" Headset Compression Ring
1	Bearing	160-6465	FSA Stainless ACB 1 1/8" 36°x45° Bearing
1	Bearing	160-67400E	FSA Stainless ACB 1.5" 36°x45° Bearing
1	Crown Race	160-5536	FSA 1.5" Crown Race

### Instinct Powerplay SL Alloy Headset

QTY	ITEM	PART NUMBER	DESCRIPTION
N/A	Headset	1194003	RMB ZS56   66 0mm Offset Headset, complete
N/A	Headset Cup Set	1194004	RMB Upper ZS56   5mm Offset Cup Set
1	Rubber O-Ring	160-7042	Top Cap Inner Rubber O-Ring
1	Top Cap	161-4430	FSA 5.3mm Top Cap inc. rubber seal
1	Split Race	160-7626	FSA 1 1/8" Headset Compression Ring
1	Bearing	160-6465	FSA Stainless ACB 1 1/8" 36°x45° Bearing
1	Bearing	160-67400E	FSA Stainless ACB 1.5" 36°x45° Bearing
1	Crown Race	160-5536	FSA 1.5" Crown Race

## SHOCK BEARING EYELET AND HARDWARE

Your frame is equipped with cartridge bearings in the rear eyelet, allowing for better small-bump compliance. These bearings are carried by cups that have a very firm press fit into the shock shaft. If you have your shock serviced, we highly recommend removing these components, as suspension service centres cannot guarantee they will be returned.

The forward shock hardware is a standard kit provided by the shock manufacturer. Please see the chart below for technical information on all shock hardware, diagrams for reference, and instructions for removing the bearing eyelet system.



**Assembly** Instinct Powerplay SL rear shock bearing eyelet

**Dimensions** 40 x 8mm (Width x Hardware Diameter)

ITEM NUMBER	QTY	ITEM	PART NUMBER	DESCRIPTION
N/A	1	SHOCK BEARING EYELET KIT	1811007	8 x 40mm Shock Bearing Eyelet Kit
6	2	Bearing	1801010	ENDURO 688 LLU MAX 16X8X5
17	2	Bearing Cup	1800031	BEARING EYELET FOR 16X8X5 BRG
71	1	Sleeve	1807028	BEARING EYELET CENTRE SLEEVE
18	2	Bearing Spacer	1800032	EYELET BEARING SPACER, T:6.3, FOR 40 MM LINK WIDTH

**Assembly** Instinct Powerplay SL Forward Shock Hardware

**Dimensions** 25 x 8mm (Shock Pin Width x Hardware Diameter)

ITEM NUMBER	QTY	ITEM	PART NUMBER	DESCRIPTION
N/A	1	Fox Complete Kit	803-03-328	FOX Mounting Hardware - 9 Piece AL 8mm x 25mm/0.984
N/A	1	RockShox Complete Kit	11.4118.091.816	RockShox, Shock Hardware, 8 X 25.0mm

**Pro Tip:** Fox Complete Kit is compatible with Rock Shox shocks eyelets. Remove the teflon bushing from the Rock Shox eyelet before installing the Fox kit.

## SHOCK BEARING EYELET AND HARDWARE

### Bearing Eyelet Removal

#### To remove the system, follow these steps

- Use the Rocky Mountain Bearing Eyelet Tool Kit (Part# 1810031)
- Install the top hat piece on one side of the bearing eyelet
- Next, install one of the cup removal tools over the bearing cup with the top hat piece installed.
- Thread the M8 screw snugly against the top hat piece.
- Install the other cup removal tool over the other bearing cup.
- Thread the M8 screw all the way in until it starts pushing on the other side. It is contacting the inside of the top hat piece.
- Keep threading until one of the cups is full pushed out.
- Next insert the drift tool through the shock eyelet and rest it firmly against the bearing cup that is still pressed in the shock eyelet.
- Gently, but firmly, hammer the drift tool until the bearing cup is fully removed from the shock eyelet.

#### If you do not have the Rocky Mountain Bearing Eyelet Tool Kit, use a blind bearing puller:

- Use a blind bearing puller (8 mm extension) to remove both bearings. Install the top hat piece on one side of the bearing eyelet
- Remove the centre sleeve.
- Use the blind bearing puller (10 mm extension) to remove the empty cups.

*NOTE: the inner diameter of the cups is 11 mm, which means the 12 mm extension won't fit (So don't force it); Use the 10 mm extension.*

To install new cups, use a bearing press or vice with soft jaws installed, making sure to press on the outer edge of the cups, and don't forget the centre spacer sleeve between the cups.

## SUSPENSION SETUP

Before changing your shock settings, it's important to educate yourself about the various adjustments that can be made.

### Spring Adjustment

Depending on the shock model, you may need to adjust the coil spring rate or air pressure to achieve the recommended sag for the Instinct Powerplay™ SL. Consult the spring chart below for recommendations on coil spring rates and air pressures.

### Rebound

Rebound adjustment controls how quickly your suspension returns to full extension after it hits a bump. Too much rebound control, and the fork or shock will move too slowly, sinking deeper and deeper into its travel under repeated hits, which will feel harsh. Too little, and the suspension can spring back too quickly, causing a loss of traction and control.

Low Speed Rebound (LSR) refers to low fork or shock speed, not trail speed. This adjustment affects rebound rate in the first portion of the travel. For the sake of bracketing, we can assume from 0% to 40% travel.

High Speed Rebound (HSR) refers to high fork or shock speed, not trail speed. This adjustment affects rebound rate in the second portion of the travel. For the sake of bracketing, we can assume from 40% to 100% travel.

## SUSPENSION SETUP

### Compression

Compression adjustment controls how quickly your suspension moves into its travel as it hits a bump. Too much compression control and the fork or shock will move too slow and the force of the impact will rely too much on the tire and your body to absorb the movement. Too little compression and the fork or shock will move too quickly making the bike feel sluggish and unresponsive.

Low speed compression (LSC) refers to low fork or shock speed, not trail speed. It controls rider weight shifts, pumping through terrain, G-outs, and other slow inputs. Too much LSC will result in a harsher ride feel; too little LSC will result in a ride feel that's too soft and unresponsive. LSC is effective throughout the entire range of travel.

High speed compression (HSC) refers to high fork or shock speed, not trail speed. It controls the ability to absorb large impacts such as square edge rocks and bottom outs. Too much HSC will result in a harsher ride feel when riding fast, rough trails with many large bumps; too little HSC will result in not enough support when hitting those large bumps and might result in using all your suspension travel.

### Hydraulic Bottom Out

Hydraulic Bottom Out (HBO) refers to the bottom out resistant that some shocks can provide in combination with an external adjuster. This affects the last 20% of the shock travel and it used for large impacts where the bike can bottom out.

Please see below tables for all OEM shock configurations for the Instinct Powerplay SL. Due to the large number of shocks compatible with the Instinct Powerplay SL, we cannot provide setup guides for models outside of the OEM specifications.

### Suspension Tips and Tricks

When tuning your suspension, write down your settings so you can refer to them later. Better yet, use an online spreadsheet on your phone!

Removing the shock on the Instinct Powerplay™ SL with its Smoothlink suspension design is easy but can require a few tips and tricks. Here's a step-by-step guide on removal. For installation, simply follow the instructions in reverse. Be sure to note the torque values included in the SOP section of this manual.

1. Shift down to the small cog on the cassette and lock the derailleur cage open if possible.
2. Remove wheel.
3. Make sure the frame areas between the seat tube and link are clear of debris and clean.
4. Remove forward shock bolt.
  - a. Remember to support the rear triangle once the forward shock hardware is removed, and gently extend it back until the seatstay bridge contacts the seat tube.
5. Remove rear shock bolt.
  - a. If required, you can remove the Ride4 chips on both sides of the link.
6. Remove shock
  - a. The bearing eyelet spacers on each side will fall away, so be sure that you place a hand below the bearing eyelet area to catch these.

## SUSPENSION SETUP

### 2025 INSTINCT POWERPLAY SL FOX FLOAT X AIR SHOCK

SHOCK DIMENSIONS

SM - MD - LG - XL = 230 X 57.5MM

SHOCK TUNE

0.4 SPACER, CS40, RL40, LMF, REZI B40

NOTES

INCREASE PRESSURE BY 10PSI | 0.7BAR FOR SM \*COUNT CLICKS FROM CLOSED: 0 CLICKS = CLOSED\*

RIDER WEIGHT	PRESSURE	SHOCK SAG	LSR	HBO	LSC	HSC
100lbs   45kg	120psi   8.3bar		10		9 - Open	
110lbs   50kg	130psi   9bar		10		9	
120lbs   55kg	140psi   9.7bar		10 - 9		8 - 9	
130lbs   59kg	150psi   10.3bar		9		8	
140lbs   64kg	160psi   11bar		9 - 8		7 - 8	
150lbs   68kg	170psi   11.7bar		8		7	
160lbs   73kg	180psi   12.4bar	SM - XL 17 - 20mm	8 - 7	Not Available	6 - 7	Not Available
170lbs   77kg	190psi   13.1bar		7		6	
180lbs   82kg	200psi   13.8bar		7 - 6		5 - 6	
190lbs   86kg	210psi   14.5bar		6		5	
200lbs   91kg	220psi   15.2bar		6 - 5		4 - 5	
210lbs   95kg	230psi   15.9bar		5		4	
220lbs   100kg	240psi   16.5bar		5 - 4		3 - 4	
230lbs   105kg	250psi   17.2bar		4		3	
240lbs   109kg	260psi   17.9bar		4 - 3		2 - 3	
250lbs   114kg	270psi   18.6bar		3		2	

### 2025 INSTINCT POWERPLAY SL FOX FLOAT AIR SHOCK

SHOCK DIMENSIONS

XS = 210 X 52.5MM

SHOCK TUNE

0.2 SPACER, CL, RM, CMF

NOTES

INCREASE PRESSURE BY 10PSI | 0.7BAR FOR SM \*COUNT CLICKS FROM CLOSED: 0 CLICKS = CLOSED\*

RIDER WEIGHT	PRESSURE	SHOCK SAG	LSR	HBO	LSC	HSC
100lbs   45kg	120psi   8.3bar		10			
110lbs   50kg	130psi   9bar		10			
120lbs   55kg	140psi   9.7bar		10 - 9			
130lbs   59kg	150psi   10.3bar		9			
140lbs   64kg	160psi   11bar		9 - 8			
150lbs   68kg	170psi   11.7bar		8			
160lbs   73kg	180psi   12.4bar	XS 15 - 18mm	8 - 7	Not Available	Start Open Adjust to preference	Not Available
170lbs   77kg	190psi   13.1bar		7			
180lbs   82kg	200psi   13.8bar		7 - 6			
190lbs   86kg	210psi   14.5bar		6			
200lbs   91kg	220psi   15.2bar		6 - 5			
210lbs   95kg	230psi   15.9bar		5			
220lbs   100kg	240psi   16.5bar		5 - 4			
230lbs   105kg	250psi   17.2bar		4			
240lbs   109kg	260psi   17.9bar		4 - 3			
250lbs   114kg	270psi   18.6bar		3			

## SUSPENSION SETUP

### 2025 INSTINCT POWERPLAY SL ROCKSHOX SUPER DELUXE AIR SHOCK

SHOCK DIMENSIONS SM - MD - LG - XL = 230 X 57.5MM | BC EDITION = 230 X 60MM SHOCK TUNE MD - LG - XL = 0 NEG 1 POS TOKEN - REBOUND 25 - COMP 30 - LOCKOUT 4 SM = 0 NEG 0 POS TOKENS - REBOUND 25 - COMP 26 - LOCKOUT 4

NOTES INCREASE PRESSURE BY 10PSI | 0.7BAR FOR SM \*COUNT CLICKS FROM CLOSED: 0 CLICKS = CLOSED\*

RIDER WEIGHT	PRESSURE	SHOCK SAG	LSR	HBO	LSC	HSC
100lbs   45kg	120psi   8.3bar		11 - 12			
110lbs   50kg	130psi   9bar		10 - 11			
120lbs   55kg	140psi   9.7bar		9 - 11			
130lbs   59kg	150psi   10.3bar		8 - 9	Start at neutral setting (3rd position)		
140lbs   64kg	160psi   11bar		8 - 10	Adjust 1 click at a time to achieve desired bottom-out feeling.		
150lbs   68kg	170psi   11.7bar	SM - XL	6 - 7	The optional Hydraulic Bottom Out kicks in to restrict the flow of oil within the last 20% of travel, offering a soft hydraulic cushion that reduces harsh bottom out.	Start at neutral setting (3rd position)	Start at neutral setting (3rd position)
160lbs   73kg	180psi   12.4bar	17 - 20mm	6 - 7		Adjust 1 click at a time to achieve desired support on low shaft speed movements, such as pumping through roller, preloading for a jump or drop, or more support while climbing.	Adjust 1 click at a time to achieve desired support on high shaft speed movements, such as square edge hits, rocky terrain, and large drops.
170lbs   77kg	190psi   13.1bar	BC Edition	5 - 6			
180lbs   82kg	200psi   13.8bar	18 - 21mm	5 - 6			
190lbs   86kg	210psi   14.5bar		4 - 5			
200lbs   91kg	220psi   15.2bar		4 - 5			
210lbs   95kg	230psi   15.9bar		3 - 4			
220lbs   100kg	240psi   16.5bar		2 - 3			
230lbs   105kg	250psi   17.2bar		2 - 3			
240lbs   109kg	260psi   17.9bar		1 - 2			
250lbs   114kg	270psi   18.6bar		1 - 2			

### 2025 INSTINCT POWERPLAY SL ROCKSHOX DELUXE AIR SHOCK

SHOCK DIMENSIONS XS = 210 X 52.5MM | BC EDITION = 210 X 55MM SHOCK TUNE MD - LG - XL = 0 NEG 1 POS TOKENS, PROGRESSIVE REB-LOW COMP TUNE, 320LB LOCKOUT SM = 0 NEG 0 POS TOKENS, PROGRESSIVE REB-L1 COMP TUNE, 320LB LOCKOUT XS = 0 NEG 0 POS TOKENS, PROGRESSIVE REB-LOW COMP TUNE, 320LB THRESHOLD

NOTES INCREASE PRESSURE BY 10PSI | 0.7BAR FOR SM \*COUNT CLICKS FROM CLOSED: 0 CLICKS = CLOSED\*

RIDER WEIGHT	PRESSURE	SHOCK SAG	LSR	HBO	LSC	HSC
100lbs   45kg	120psi   8.3bar		10			
110lbs   50kg	130psi   9bar		10			
120lbs   55kg	140psi   9.7bar		10 - 9			
130lbs   59kg	150psi   10.3bar		9			
140lbs   64kg	160psi   11bar		9 - 8			
150lbs   68kg	170psi   11.7bar	XS	8			
160lbs   73kg	180psi   12.4bar	15 - 18mm	8 - 7			
170lbs   77kg	190psi   13.1bar	BC Edition	7	Not Available	Start Open Adjust to preference	Not Available
180lbs   82kg	200psi   13.8bar	16 - 19mm	7 - 6			
190lbs   86kg	210psi   14.5bar		6			
200lbs   91kg	220psi   15.2bar		6 - 5			
210lbs   95kg	230psi   15.9bar		5			
220lbs   100kg	240psi   16.5bar		5 - 4			
230lbs   105kg	250psi   17.2bar		4			
240lbs   109kg	260psi   17.9bar		4 - 3			
250lbs   114kg	270psi   18.6bar		3			

## CRITICAL DIMENSIONS

ITEM NUMBER	CATEGORY	ITEM	DIMENSION	PART NUMBER	DESCRIPTION
1	Headset	Carbon Frame Headset	FSA No.85-1 0mm Offset		FSA No.85-1 0mm Offset Headset, complete. See Headset chart for information
		Carbon Frame Headset Cup Set	FSA No.85-1 5mm Offset		FSA No.85-1 5mm Offset cups only. See Headset chart for information
		Alloy Frame Headset	FSA ZS56 66 0mm Offset		FSA RMB ZS56 66 0mm Offset Headset, complete. See Headset chart for information
		Alloy Frame Headset Cup Set	FSA ZS56 66 5mm Offset		FSA RMB ZS56 66 5mm Offset cups only. See Headset chart for information
2	Fork	Fork Travel	150mm		Compatible with 160mm
		Fork Offset	27.5"   XS = 37mm		
			29"   SM - MD - LG - XL = 42 - 44mm		
		Maximum Axle to Crown Height	27.5"   XS = 557.6mm		
			29"   SM - MD - LG - XL = 575mm		
3	Shock	Shock Size	XS = 210 x 52.5mm		XS frames are compatible with 210 x 55mm shocks. This increases rear wheel travel to 150mm.
			SM - MD - LG - XL = 230 x 57.5mm		SM - MD - LG - XL frames are compatible with 230 x 60mm shocks. This increases rear wheel travel to 150mm.
		Shock Tune	See Description		Refer to Shock Setup chart for tune information
		Forward Shock Hardware	25 x 8mm		See Shock Hardware chart for information
		Rear Shock Hardware	40 x 8mm	1811007	Requires custom bearing eyelet hardware. See Shock Hardware chart for information
	Approved Shock Fitment	See Description		All Fox rear shock models. All RockShox rear shock models. All Cane Creek Shock models. Other rear shock manufacturers' models may fit, but will require fitment on frame to check clearances at full extension and compression.	
4	Seatpost	Seat Tube Inner Diameter	30.9mm		
		Seat Tube Outer Diameter	34.9mm		
		Seat Tube Minimum Insertion	100mm		
			XS = 220mm		
			SM = 230mm		
		Seat Tube Machined Ream Depth	MD = 275mm		For seatpost fitment information, refer to the seatpost fitment section in this manual
	(Identical on Carbon & Alloy)	LG = 305mm			
		XL = 335mm			

## CRITICAL DIMENSIONS

ITEM NUMBER	CATEGORY	ITEM	DIMENSION	PART NUMBER	DESCRIPTION
		Chainring Size Range	34T		Instinct Powerplay SL bikes are only compatible with 34 tooth chainrings.
		OEM Chainring Size   Chain Length	27.5"   XS = 34T   122L 29"   SM - MD = 34T   122L 29"   LG - XL = 34T   124L		
5	Crankset	Lower Chain Guide Kit	See Description	1995026	Bashguard bracket with idler, 2025 Instinct Powerplay SL
		Chain Guide	See Description	1995013	Motor Output Chainguide, 2025 Instinct Powerplay SL
		Bashguard	2-Bolt Custom Mount		2-Bolt mounting pattern to fit Instinct Powerplay SL bashguards only
		Bottom Bracket	PressFit BB92		Remove the bottom bracket's inner plastic sleeve to install.
		Chainline	51mm		Compatible Rocky Mountain Ratchet Spider assembly only.
7	Brake	Maximum Rotor Diameter	223mm		
		Maximum Rotor Thickness	2.0mm		
8	Wheel	Wheel Size	XS = 27.5" SM - MD - LG - XL = 29"		XS is only compatible with 27.5" wheels. MX compatible on all sizes with dedicated link (Link C   1815087)
		Maximum Tire Width	2.5"   63mm		
9	Rear Hub	Hub Spacing	12 x 148mm		
		Rear Axle	12 x 1.0 x 173mm	3222000	Diameter 12mm x Thread Pitch 1.0mm x Length 173mm
		Complete Hanger Kit	See Description	1812002	Includes Hanger, nut, and washer. For individual parts see exploded diagram
		UDH   Transmission	See Description		Frame is UDH and Eagle Transmission compatible.

## FASTENER TORQUE SPECIFICATIONS

Correct tightening torque of threaded fasteners is very important to your safety. Always tighten fasteners to the correct torque. In case of a conflict between the instructions in this manual and information provided by a component manufacturer, consult with your dealer or the manufacturer's customer service representative for clarification. Bolts that are too tight can stretch and deform. Bolts that are too loose can move and fatigue. Either mistake can lead to a sudden failure of the bolt.

Always use a correctly calibrated torque wrench to tighten critical fasteners on your bike. Carefully follow the torque wrench manufacturer's instructions on the correct way to set and use the torque wrench for accurate results.

### EXPLODED VIEW

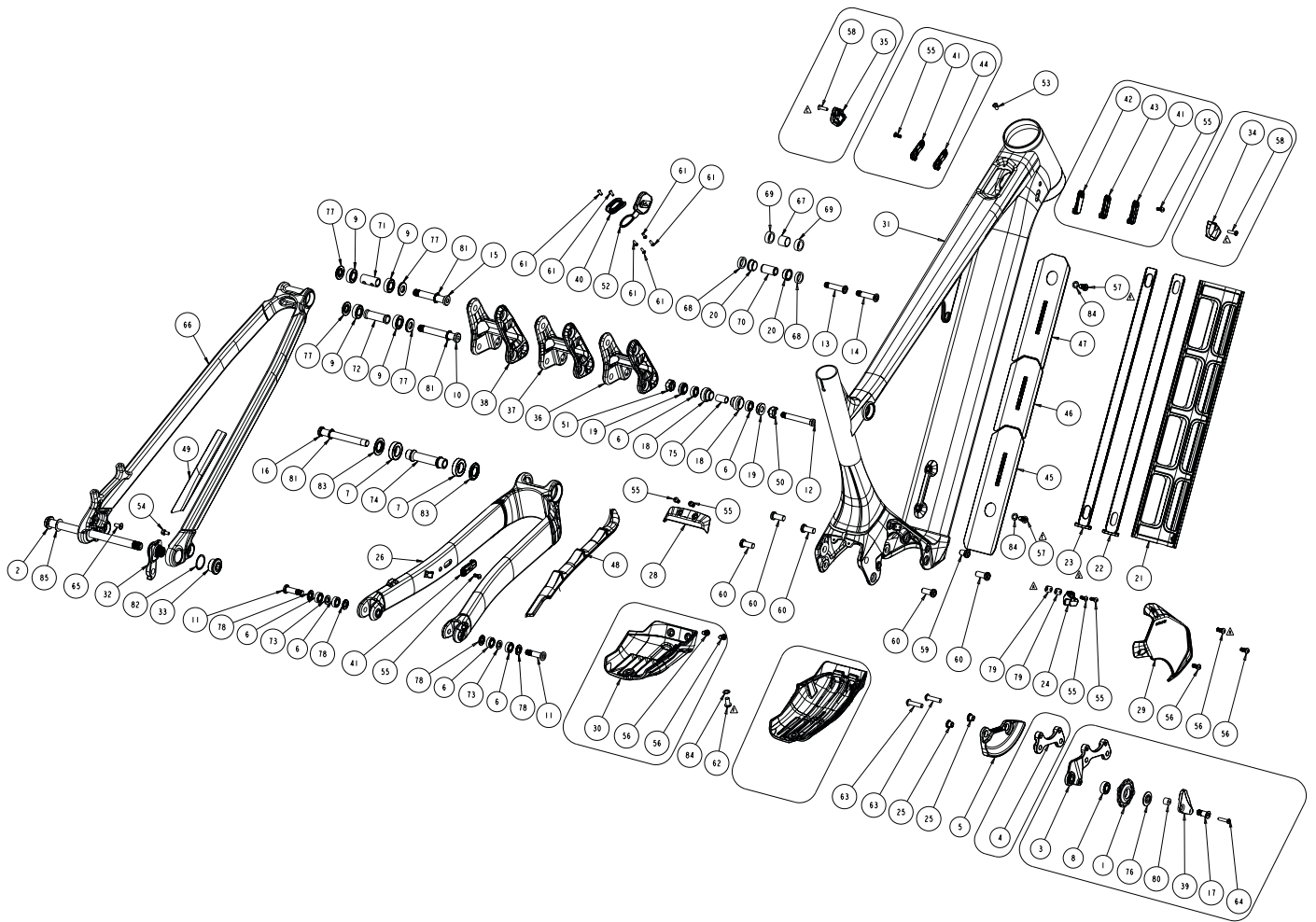

## SMALL PARTS KITS LIST

2025 INSTINCT POWERPLAY SL CARBON ALLOY							
# LIST	P1	QTY	ITEM	PART NO.	SUPPLIER	REVISION	DESCRIPTION
37	1	LINK		1815085 1095002	ZCA013		<b>2025 INSTINCT PP LINK 29"</b> MY25 INSTINCT POWERPLAY - LINK B
36	1	LINK		1815086 1095001	ZCA013		<b>2025 INSTINCT PP LINK 27.5"</b> MY25 INSTINCT POWERPLAY - LINK A
38	1	LINK		1815087 1095003	ZCA013		<b>2025 INSTINCT PP MULLET LINK</b> MY25 INSTINCT POWERPLAY - LINK C
32	1	HANGER		1812002 1092003	PTW047		<b>2022 HANGER KIT 12 x1.0</b> MY22 REAR DER. HANGER, M12X1, UDH COMPATIBLE
33	1	HANGER NUT		1801008	PTW047		RMB UDH HANGER NUT, 7075_T6, HARD BLACK ANODIZED
82	1	WASHER		1801009	PTW047		WASHER, 20X24X0.5MM, 304 SS
16	1	BOLT		1815088 1805154	PTW047		<b>2025 INSTINCT PP PIVOT BOLT KIT</b> BOLT, MAIN PIVOT, 10 MM OD, M10x1.25, 86 MM L, 6 MM HEX
10	1	BOLT		1801004	PTW047		LINK BOLT, LOWER, M10X1.0, L:70.5, 6MM HEX
15	1	BOLT		1804058	PTW047		UPPER LINK BOLT, M10x1.0, L:59.4
11	2	BOLT		1801007	PTW047		ALTITUDE DROPOUT BOLT, M8X1.0, L:30, 6MM HEX
71	1	SLEEVE		1800008	PTW047		TT BEARING SLEEVE, ID:10, OD:14, L:29
72	1	SLEEVE		1800010	PTW047		SS BEARING SLEEVE, ID:10, OD:14, L:41, NECKED
74	1	SLEEVE		1805156	PTW047		SLEEVE, MAIN PIVOT, 10MM ID, 52.5 MM L
73	2	SLEEVE		1800040	PTW047		DROPOUT BEARING SLEEVE, OD:14, ID:8, T:1.8, 6061 ALU
77	4	SPACER		1800009	PTW047		LINK BEARING SPACER, OD:22, ID:10, T:2.5
78	4	SPACER		1800039	PTW047		DO BEARING SPACER, OD:16, ID:8, T:1.75, 6061 ALU
81	3	WASHER		1800019	PTW047		WASHERID: 10.2, OD: 15.5, T:1
83	2	WASHER		1805155	PTW047		WASHER, MAIN PIVOT, 15MM ID, 27.5MM OD, 2.5MM T
11	2	BOLT		1814055 1801007	PTW047		<b>DROPOUT PIVOT BOLT KIT</b> ALTITUDE DROPOUT BOLT, M8X1.0, L:30, 6MM HEX
6	6	BEARING		1815089 1801010	ZCA013		<b>2025 INSTINCT PP PIVOT BEARING KIT</b> ENDURO 688 LLU MAX 16X8X5
9	4	BEARING		1807042			ENDURO 6900 2RS MAX 22X10X6
7	2	BEARING		1805159			ENDURO 6902 LLU MAX 28X15X7
12	1	BOLT		1815090 1802008	PTW047		<b>2025 INST PP AL SHOCK BOLT KIT</b> RIDE 4 BOLT, M8 x 1, OD: 8 mm, L:56, 5 mm Hex
14	1	BOLT		1804057			SHOCK BOLT, M8X1.0, L:35, 5mm HEX
12	1	BOLT		1815091 1802008	PTW047		<b>2025 INST PP CR SHOCK BOLT KIT</b> RIDE 4 BOLT, M8 x 1, OD: 8 mm, L:56, 5 mm Hex
13	1	BOLT		1803026			SHOCK BOLT, M8X1.0, L:36.5, 5mm hex
6	2	BEARING		1811007 1801010	ZCA013		<b>SHOCK BEARING EYELET KIT 2021</b> ENDURO 688 LLU MAX 16X8X5
75	1	SLEEVE		1807028	PTW047		BEARING EYELET CENTRE SLEEVE
18	2	BRG CUP		1800031	PTW048		BEARING EYELET FOR 16X8X5 BRG
19	2	BRG SPACER		1800032	PTW049		EYELET BEARING SPACER, T:6.3, FOR 40 MM LINK WIDTH
2	1	AXLE, REAR		1812007 3222000	PTW047		<b>AXLE KIT BOOST 12X1.0</b> REAR AXLE 12X1.0 L:173MM, HARD BLACK ANODIZE
85	1	WASHER		3227006	PTW047		WASHER, 12x19x0.5MM, 304 SS
34	1	HT PORT COVER		1815092 1803012	PTW047		<b>**** 2025 INST PP HT PANEL KIT (NEW)</b> 2023 SLAYER CARBON HT PORT COVER, RIGHT
35	1	HT PORT COVER		1803013	PTW047		2023 SLAYER CARBON HT PORT COVER, LEFT
58	2	SCREW		1805077-BK	PTW048		C'SUNK SOCKET SCREW, M4X16, STAINLESS STEEL, BLACK

## SMALL PARTS KITS LIST

		<b>1815093</b>	<b>ZCA013</b>	<b>POWERPLAY ALLOY FRAME HT CABLE PORT KIT</b>
55	3 SCREW	1804060		M4X0.7, 10MM, 2.5 HEX, BUTTON HEAD, SS, BLACK
41	3 PORT COVER	1093011		ALLOY CABLE PORT COVER DOUBLE HOLE
42	1 PORT COVER	1093012		ALLOY CABLE PORT COVER BLANK
43	1 PORT COVER	1093013		ALLOY CABLE PORT COVER SINGLE 4mm HOLE
44	1 PORT COVER	1093014		ALLOY CABLE PORT COVER SINGLE 5mm HOLE
		<b>1815094</b>		<b>ALLOY POWERPLAY FRAME CS CABLE PORT KIT STD SIZE</b>
41	1 PORT COVER	1093011		ALLOY CABLE PORT COVER DOUBLE HOLE
55	1 SCREW	1804060		M4X0.7, 10MM, 2.5 HEX, BUTTON HEAD, SS, BLACK
		<b>1812010</b>	<b>PTW047</b>	<b>RIDE 4 THREADED CHIP KIT</b>
50	1 RIDE 4 CHIP	1802009	PTW047	RIDE 4 CHIP, NO THREAD.
51	1 RIDE 4 CHIP	1802010	PTW047	RIDE 4 CHIP, THREADED, M8 x 1.
		<b>1815095</b>	<b>ZCA013</b>	<b>2025 INSTINCT PP PROTECTION KIT XS/SM</b>
48	1 PROTECTOR	1705006		2025 INSTINCT POWERPLAY CHAINSTAY PROTECTOR
49	1 PROTECTOR	3702021		SEATSTAY PROTECTOR, TRIMMED
45	1 PROTECTOR	1705003		DOWNTUBE PROTECTOR - A - 2025 INSTINCT POWERPLAY
46	2 PROTECTOR	1705004		DOWNTUBE PROTECTOR - B - 2025 INSTINCT POWERPLAY
		<b>1815096</b>	<b>ZCA013</b>	<b>2025 INSTINCT PP PROTECTION KIT MD/LG/XL</b>
48	1 PROTECTOR	1705006		2025 INSTINCT POWERPLAY CHAINSTAY PROTECTOR
49	1 PROTECTOR	3702021		SEATSTAY PROTECTOR, TRIMMED
45	1 PROTECTOR	1705003		DOWNTUBE PROTECTOR - A - 2025 INSTINCT POWERPLAY
46	1 PROTECTOR	1705004		DOWNTUBE PROTECTOR - B - 2025 INSTINCT POWERPLAY
47	1 PROTECTOR	1705005		DOWNTUBE PROTECTOR - C - 2025 INSTINCT POWERPLAY
		<b>1815097</b>		<b>2025 INSTINCT PP BB COVER SM/MD/LG/XL</b>
27	1 COVER	1995005		BOTTOM BRACKET COVER, CO-MOLDED, 2025 IPP
62	1 SCREW	1805170		SCREW, BUTTON HEAD, 18-8 SS, RAW STAINLESS, M6X1.0, 12MM LENGTH
84	1 WASHER	1805172		WASHER, 6x10x0.5MM, 304 SS
		<b>1815098</b>		<b>2025 INSTINCT PP BB COVER XS</b>
30	1 COVER	1995018		FOR X-SMALL ONLY, BOTTOM BRACKET COVER, 2025 INSTINCT POWERPLAY
62	1 SCREW	1805170		SCREW, BUTTON HEAD, 18-8 SS, RAW STAINLESS, M6X1.0, 12MM LENGTH
84	1 WASHER	1805172		WASHER, 6x10x0.5MM, 304 SS
56	2 SCREW	1804063		LOW PROFILE SOCKET HEAD SCREW, M5X10, STAINLESS STEEL, BLACK
		<b>1815099</b>		<b>2025 INSTINCT PP MAIN PIVOT COVER</b>
28	1 COVER	1995016		MAIN PIVOT COVER, 2025 INSTINCT POWERPLAY
55	2 SCREW	1804060		M4X0.7, 10MM, 2.5 HEX, BUTTON HEAD, SS, BLACK
		<b>1815100</b>	<b>PTW047</b>	<b>UDH STOP SCREW KIT M4X8</b>
54	1 SCREW	1802012		UDH STOP SCREW M4X8
		<b>1814050</b>	<b>ZCA013</b>	<b>5M OFFSET HEAD SET CUPS KIT CR BIKES</b>
1	HEAD SET CUP	1194002	PUS105	FSA 5MM OFFSET OVAL CUPS W/ORING CR BIKES
		<b>1814051</b>	<b>ZCA013</b>	<b>5M OFFSET HEAD SET CUPS KIT AL BIKES</b>
1	HEAD SET CUP	1194004	PUS105	FSA 5MM OFFSET CUPS AL BIKES
		<b>1814052</b>	<b>ZCA013</b>	<b>OVAL OFFSET HEADSET KIT CR BIKES</b>
1	HEADSET	1194001	PUS105	FSA NO.85 1.5" OMM OFFSET OVAL CUPS STAINLESS
		<b>1814053</b>	<b>ZCA013</b>	<b>OFFSET HEADSET KIT AL BIKES</b>
1	HEADSET	1194003	PUS105	FSA ZS56   66 OMM OFFSET HS STAINLESS STEEL
		<b>1815101</b>		<b>2025 INSTINCT PP BASH GUARD KIT</b>
5	1 BASH GUARD PLATE	1995028		BASH GUARD PLATE - 2025 INSTINCT POWERPLAY
25	2 CHAINRING BOLT	1805173		CHAINRING BOLT, CUSTOM, M8 X 0.75, LENGTH 6MM

## SMALL PARTS KITS LIST

		<b>1815102</b>		<b>2025 INSTINCT PP CHAIN GUIDE KIT W/BASH GUARD</b>
5	1 BASH GUARD PLATE	1995028		BASH GUARD PLATE - 2025 INSTINCT POWERPLAY
4	1 BASH GUARD BRACKET	1995027		BASH GUARD BRACKET, WITHOUT IDLER - 2025 INSTINCT POWERPLAY
63	2 SCREW	1805171		SCREW, BUTTON HEAD, 18-8 SS, BLACK, M6X1.0, 25MM LENGTH
25	2 CHAINRING BOLT	1805173		CHAINRING BOLT, CUSTOM, M8 X 0.75, LENGTH 6MM
		<b>1815103</b>		<b>2025 INSTINCT PP CHAIN GUIDE KIT W/ BASH GUARD &amp; IDLER</b>
3	1 BASH GUARD BRACKET	1995026		BASH GUARD BRACKET, WITH IDLER - 2025 INSTINCT POWERPLAY
17	1 BOLT, M8X18	1807126		BOLT M8 X 18MM CUSTOM. 6061 HARD BLACK ANO.
39	1 PLATE	1094020		REAPER POWERPLAY LOWER PULLEY PLATE
64	1 SCREW, M4X20	1809011		C'SUNK SOCKET SCREW, M4x20mm, STAINLESS STEEL 316
80	1 SPACER	3399006		LOWER CHAIN GUIDE SPACER
1	1 11T COG	1347012	REV B	11T COG, FOR 19mm BEARING
8	1 BEARING	1807036		ENDURO 698 LLU 19X8X6
76	1 SPACER	1347013		CHAINSTAY PULLEY GUIDE SPACER,
5	1 BASH GUARD PLATE	1995028		BASH GUARD PLATE - 2025 INSTINCT POWERPLAY
63	2 SCREW	1805171		SCREW, BUTTON HEAD, 18-8 SS, BLACK, M6X1.0, 25MM LENGTH
25	2 CHAINRING BOLT	1805173		CHAINRING BOLT, CUSTOM, M8 X 0.75, LENGTH 6MM
		<b>1998024</b>		<b>CHAIN STAY PULLEY KIT</b>
1	1 11T COG	1347012	REV B	11T COG, FOR 19mm BEARING
8	1 BEARING	1807036		ENDURO 698 LLU 19X8X6
76	1 SPACER	1347013		CHAINSTAY PULLEY GUIDE SPACER,
		<b>1815104</b>	<b>PTW047</b>	<b>2025 INSTINCT POWERPLAY SL UPPER CHAIN GUIDE KIT</b>
24	1 CHAIN GUIDE	1995013		MOTOR OUTPUT CHAIN GUIDE, 2025 INSTINCT POWERPLAY
55	2 SCREW	1804060		M4X0.7, 10MM, 2.5 HEX, BUTTON HEAD, SS, BLACK
79	2 SPACER	1805191		CHAINGUIDE SPACER, 0.5MM, 304 STAINLESS STEEL, 2025 IPP
		<b>1815105</b>	<b>PTW047</b>	<b>2025 INSTINCT POPWERPLAY BATTERY BOLT KIT</b>
57	2 SCREW	1804065		M6 X 14MM, LOW BUTTON HEAD SCREW, SS, BLACK COATED
84	1 WASHER	1805172		WASHER, 6x10x0.5MM, 304 SS
		<b>1815106</b>	<b>PTW047</b>	<b>2025 INSTINCT POWERPLAY CHARGE PORT KIT</b>
40	1 PLATE	1995015		CHARGE PORT PLATE, 2025 INSTINCT POWERPLAY
52	1 RUBBER CAP	1995014		CHARGE PORT RUBBER CAP, 2025 INSTINCT POWERPLAY
61	6 SCREW	1805160		SCREW, BUTTON HEAD, 18-8 SS, BLACK, M3X0.5, L:8MM
		<b>1815107</b>	<b>PTW047</b>	<b>2025 INSTINCT PP SL ALLOY CABLE FLUTE XS/SM</b>
21	1 CABLE GUIDE	1995006		DOWNTUBE CABLE GUIDE FLUTE - 2025 INSTINCT POWERPLAY
22	1 CABLE GUIDE	1995007		DOWNTUBE CABLE GUIDE WEDGE - 2025 INSTINCT POWERPLAY
		<b>1815114</b>	<b>PTW047</b>	<b>2025 INSTINCT PP SL ALLOY CABLE FLUTE MD/LG/XL</b>
21	1 CABLE GUIDE	1995006		DOWNTUBE CABLE GUIDE FLUTE - 2025 INSTINCT POWERPLAY
23	1 CABLE GUIDE	1995048		DOWNTUBE CABLE GUIDE WEDGE - SLIM - 2025 IPP
		<b>1815108</b>	<b>PTW047</b>	<b>2025 INSTINCT POWERPLAY SL DRIVE SIDE MOTOR COVER</b>
29	1 COVER	1995017		DS COVER, 2025 INSTINCT POWERPLAY
56	3 SCREW	1804063		LOW PROFILE SOCKET HEAD SCREW, M5X10, STAINLESS STEEL, BLACK
		<b>1815109</b>	<b>PTW047</b>	<b>2025 INSTINCT POWERPLAY SL MOTOR MOUNT BOLT KIT</b>
60	5 SCREW	1805158		MOTOR MOUNTING SCREW, M8x1.25, 18 MM L, 304 SS, BUTTON HEAD
59	1 SCREW	1805157		MOTOR MOUNTING SCREW, M8x1.25, 10 MM L, 304 SS, BUTTON HEAD

## PARTS LIST AND ASSEMBLY INSTRUCTIONS

#	QTY	ITEM	PART NO.	DESCRIPTION	SUPPLIER	TORQUE(Nm)	INSTALLATION NOTES
1	1	11T COG	1347012	11T COG, FOR 19mm BEARING	OVERTOP		
2	1	AXLE, REAR	3222000	REAR AXLE 12X1.0 L:173MM, HARD BLACK ANODIZE	OVERTOP		10 Grease axle shaft and threads
3	1	BASH GUARD BRACKET	1995026	BASH GUARD BRACKET, WITH IDLER - 2025 INSTINCT POWERPLAY	SHING FONG		
4	1	BASH GUARD BRACKET	1995027	BASH GUARD BRACKET, WITHOUT IDLER - 2025 INSTINCT POWERPLAY	SHING FONG		
5	1	BASH GUARD PLATE	1995028	BASH GUARD PLATE - 2025 INSTINCT POWERPLAY	CREATE THINK		
6	6	BEARING	1801010	ENDURO 688 LLU MAX 16X8X5	ABI		Grease bearing race faces before installation
7	2	BEARING	1805159	ENDURO 6902 LLU MAX 28X15X7	ABI		Grease bearing race faces before installation
8	1	BEARING	1807036	ENDURO 698 LLU 19X8X6	ABI		Grease bearing race faces before installation
9	4	BEARING	1807042	ENDURO 6900 2RS MAX 22X10X6	ABI		Grease bearing race faces before installation
10	1	BOLT	1801004	LINK BOLT, LOWER, M10X1.0, L:70.5, 6MM HEX	OVERTOP		10 Grease axle shaft, Loctite 243 (blue) on threads
11	2	BOLT	1801007	ALTITUDE DROPOUT BOLT, M8X1.0, L:30, 6MM HEX	OVERTOP		10 Grease axle shaft, Loctite 243 (blue) on threads
12	1	BOLT	1802008	RIDE 4 BOLT, M8 x 1, OD: 8 mm, L:56, 5 mm Hex	OVERTOP		10 Grease axle shaft, Loctite 243 (blue) on threads
13	1	BOLT	1803026	SHOCK BOLT, M8X1.0, L:36.5, 5mm hex	OVERTOP		10 Grease axle shaft, Loctite 243 (blue) on threads
14	1	BOLT	1804057	SHOCK BOLT, M8X1.0, L:35, 5mm HEX	OVERTOP		10 Grease axle shaft, Loctite 243 (blue) on threads
15	1	BOLT	1804058	UPPER LINK BOLT, M10x1.0, L:59.4	OVERTOP		10 Grease axle shaft, Loctite 243 (blue) on threads
16	1	BOLT	1805154	BOLT, MAIN PIVOT, 10 MM OD, M10x1.25, 86 MM L, 6 MM HEX	OVERTOP		14 Grease axle shaft, Loctite 243 (blue) on threads
17	1	BOLT, M8X18	1807126	BOLT M8 X 18MM CUSTOM. 6061 HARD BLACK ANO.	OVERTOP		8 Grease axle shaft, Loctite 243 (blue) on threads
18	2	BRG CUP	1800031	BEARING EYELET FOR 16X8X5 BRG	OVERTOP		
19	2	BRG SPACER	1800032	EYELET BEARING SPACER, T:6.3, FOR 40 MM LINK WIDTH	OVERTOP		
20	2	BUSHING, FOX	N/A	FOX_IGUS_BUSHING			
21	1	CABLE GUIDE	1995006	DOWNTUBE CABLE GUIDE FLUTE - 2025 INSTINCT POWERPLAY	CREATE THINK		
22	1	CABLE GUIDE	1995007	DOWNTUBE CABLE GUIDE WEDGE - 2025 INSTINCT POWERPLAY	CREATE THINK		
23	1	CABLE GUIDE	1995048	DOWNTUBE CABLE GUIDE WEDGE - SLIM - 2025 IPP	CREATE THINK		USE ONLY FOR ALLOY FT SIZE X-SMALL & SMALL
24	1	CHAIN GUIDE	1995013	MOTOR OUTPUT CHAIN GUIDE, 2025 INSTINCT POWERPLAY	CREATE THINK		
25	2	CHAINRING BOLT	1805173	CHAINRING BOLT, CUSTOM, M8 X 0.75, LENGTH 6MM	OVERTOP		
26	1	CHAINSTAYS	SEE TABLE	CHAINSTAYS - MY25 INSTINCT POWERPLAY	MK (RANBOW)		
27	1	COVER	1995005	BOTTOM BRACKET COVER, CO-MOLDED, 2025 IPP	CREATE THINK		
28	1	COVER	1995016	MAIN PIVOT COVER, 2025 INSTINCT POWERPLAY	CREATE THINK		
29	1	COVER	1995017	DS COVER, 2025 INSTINCT POWERPLAY	CREATE THINK		
30	1	COVER	1995018	FOR X-SMALL ONLY, BOTTOM BRACKET COVER, 2025 INSTINCT POWERPLAY	CREATE THINK		
31	1	FRONT TRIANGLE	SEE TABLE	FRONT TRIANGLE - MY25 INSTINCT POWERPLAY	MK (RANBOW)		
32	1	HANGER	1092003	MY22 REAR DER. HANGER, M12X1, UDH COMPATIBLE	OVERTOP		
33	1	HANGER NUT	1801008	RMB UDH HANGER NUT, 7075_T6, HARD BLACK ANODIZED	OVERTOP		20 Apply loctite 243 (Blue) on hanger's external threads only
34	1	HT PORT COVER	1803012	2023 SLAYER CARBON HT PORT COVER, RIGHT	OVERTOP		
35	1	HT PORT COVER	1803013	2023 SLAYER CARBON HT PORT COVER, LEFT	OVERTOP		
36	1	LINK	1095001	MY25 INSTINCT POWERPLAY - LINK A	MK (RANBOW)		
37	1	LINK	1095002	MY25 INSTINCT POWERPLAY - LINK B	MK (RANBOW)		
38	1	LINK	1095003	MY25 INSTINCT POWERPLAY - LINK C	MK (RANBOW)		DO NOT ORDER, DO NOT INCLUDE
39	1	PLATE	1094020	REAPER POWERPLAY LOWER PULLEY PLATE	OVERTOP		
40	1	PLATE	1995015	CHARGE PORT PLATE, 2025 INSTINCT POWERPLAY	CREATE THINK		
41	3	PORT COVER	1093011	ALLOY CABLE PORT COVER DOUBLE HOLE	CREATE THINK		
42	1	PORT COVER	1093012	ALLOY CABLE PORT COVER BLANK	CREATE THINK		
43	1	PORT COVER	1093013	ALLOY CABLE PORT COVER SINGLE 4mm HOLE	CREATE THINK		
44	1	PORT COVER	1093014	ALLOY CABLE PORT COVER SINGLE 5mm HOLE	CREATE THINK		
45	1	PROTECTOR	1705003	DOWNTUBE PROTECTOR - A - 2025 INSTINCT POWERPLAY	CREATE THINK		
46	1	PROTECTOR	1705004	DOWNTUBE PROTECTOR - B - 2025 INSTINCT POWERPLAY	CREATE THINK		
47	1	PROTECTOR	1705005	DOWNTUBE PROTECTOR - C - 2025 INSTINCT POWERPLAY	CREATE THINK		
48	1	PROTECTOR	1705006	2025 INSTINCT POWERPLAY CHAINSTAY PROTECTOR	CREATE THINK		
49	1	PROTECTOR	3702021	SEATSTAY PROTECTOR, TRIMMED	VELO		
50	1	RIDE 4 CHIP	1802009	RIDE 4 CHIP, NO THREAD.	OVERTOP		
51	1	RIDE 4 CHIP	1802010	RIDE 4 CHIP, THREADED, M8 x 1.	OVERTOP		
52	1	RUBBER CAP	1995014	CHARGE PORT RUBBER CAP, 2025 INSTINCT POWERPLAY	CREATE THINK		
53	1	SCREW	1800024-BK	C'SUNK SOCKET SCREW, M4x10MM, 10.9 STEEL, BLACK	OVERTOP		1 Apply grease on screw threads
54	1	SCREW	1802012	UDH STOP SCREW M4X8	OVERTOP		2 Apply loctite 243 (Blue) on screw threads
55	7	SCREW	1804060	M4X0.7, 10MM, 2.5 HEX, BUTTON HEAD, SS, BLACK	OVERTOP		1 Apply grease on screw threads
56	5	SCREW	1804063	LOW PROFILE SOCKET HEAD SCREW, M5X10, STAINLESS STEEL, BLACK	OVERTOP		2 Apply grease on screw threads
57	2	SCREW	1804065	M6 X 14MM, LOW BUTTON HEAD SCREW, SS, BLACK COATED	OVERTOP		4 Dry installation
58	2	SCREW	1805077-BK	C'SUNK SOCKET SCREW, M4X16, STAINLESS STEEL, BLACK	OVERTOP		1 Apply grease on screw threads
59	1	SCREW	1805157	MOTOR MOUNTING SCREW, M8x1.25, 10 MM L, 304 SS, BUTTON HEAD	OVERTOP		10 Apply Loctite 243 (blue) on screw threads
60	5	SCREW	1805158	MOTOR MOUNTING SCREW, M8x1.25, 18 MM L, 304 SS, BUTTON HEAD	OVERTOP		14 Apply Loctite 243 (Blue) on screw threads
61	6	SCREW	1805160	SCREW, BUTTON HEAD, 18-8 SS, BLACK, M3X0.5, L:8MM	OVERTOP		0.5 Apply grease on screw threads
62	1	SCREW	1805170	SCREW, BUTTON HEAD, 18-8 SS, RAW STAINLESS, M6X1.0, 12MM LENGTH	OVERTOP		4 Dry installation
63	2	SCREW	1805171	SCREW, BUTTON HEAD, 18-8 SS, BLACK, M6X1.0, 25MM LENGTH	OVERTOP		8 Apply loctite 243 (Blue) on screw threads
64	1	SCREW, M4X20	1809011	C'SUNK SOCKET SCREW, M4x20mm, STAINLESS STEEL 316	OVERTOP		2 Apply loctite 243 (Blue) on screw threads
65	1	SCREW, M5X12	1807152	C'SUNK SOCKET SCREW, M5-0.8x12mm. STAINLESS BLACK	OVERTOP		2 Apply loctite 243 (Blue) on threads
66	1	SEATSTAYS	SEE TABLE	SEATSTAYS - MY25 INSTINCT POWERPLAY	MK (RANBOW)		
67	1	SHOCK BUSHING	N/A	SHOCK BUSHING, ID:12.7mm, OD:15mm, L:12.7mm, STEEL			
68	2	SHOCK REDUCER	N/A	FOX STD REDUCER FOR 25MM PIN			
69	2	SHOCK REDUCER	N/A	SRAM STD REDUCER FOR 25MM PIN			
70	1	SHOCK, PIN	N/A	SHOCK PIN: ID:8 x 25 mm LONG; ALUMINUM			
71	1	SLEEVE	1800008	TT BEARING SLEEVE, ID:10, OD:14, L:29	OVERTOP		
72	1	SLEEVE	1800010	SS BEARING SLEEVE, ID:10, OD:14, L:41, NECKED	OVERTOP		
73	2	SLEEVE	1800040	DROPOUT BEARING SLEEVE, OD:14, ID:8, T:1.8, 6061 ALU	OVERTOP		

## PARTS LIST AND ASSEMBLY INSTRUCTIONS

74	1 SLEEVE	1805156 SLEEVE, MAIN PIVOT, 10MM ID, 52.5 MM L	OVERTOP	Grease bearing contact surfaces before installation
75	1 SLEEVE	1807028 BEARING EYELET CENTRE SLEEVE	OVERTOP	
76	1 SPACER	1347013 CHAINSTAY PULLEY GUIDE SPACER,	OVERTOP	
77	4 SPACER	1800009 LINK BEARING SPACER, OD:22, ID:10, T:2.5	OVERTOP	
78	4 SPACER	1800039 DO BEARING SPACER, OD:16, ID:8, T:1.75, 6061 ALU	OVERTOP	
79	2 SPACER	1805191 CHAINGUIDE SPACER, 0.5MM, 304 STAINLESS STEEL, 2025 IPP	OVERTOP	
80	1 SPACER	3399006 LOWER CHAIN GUIDE SPACER	SHING FONG	
81	3 WASHER	1800019 WASHERID: 10.2, OD: 15.5, T:1	OVERTOP	
82	1 WASHER	1801009 WASHER, 20X24X0.5MM, 304 SS	OVERTOP	
83	2 WASHER	1805155 WASHER, MAIN PIVOT, 15MM ID, 27.5MM OD, 2.5MM T	OVERTOP	
84	3 WASHER	1805172 WASHER, 6x10x0.5MM, 304 SS	OVERTOP	
85	1 WASHER	3227006 WASHER, 12x19x0.5MM, 304 SS	OVERTOP	

## IMAGES

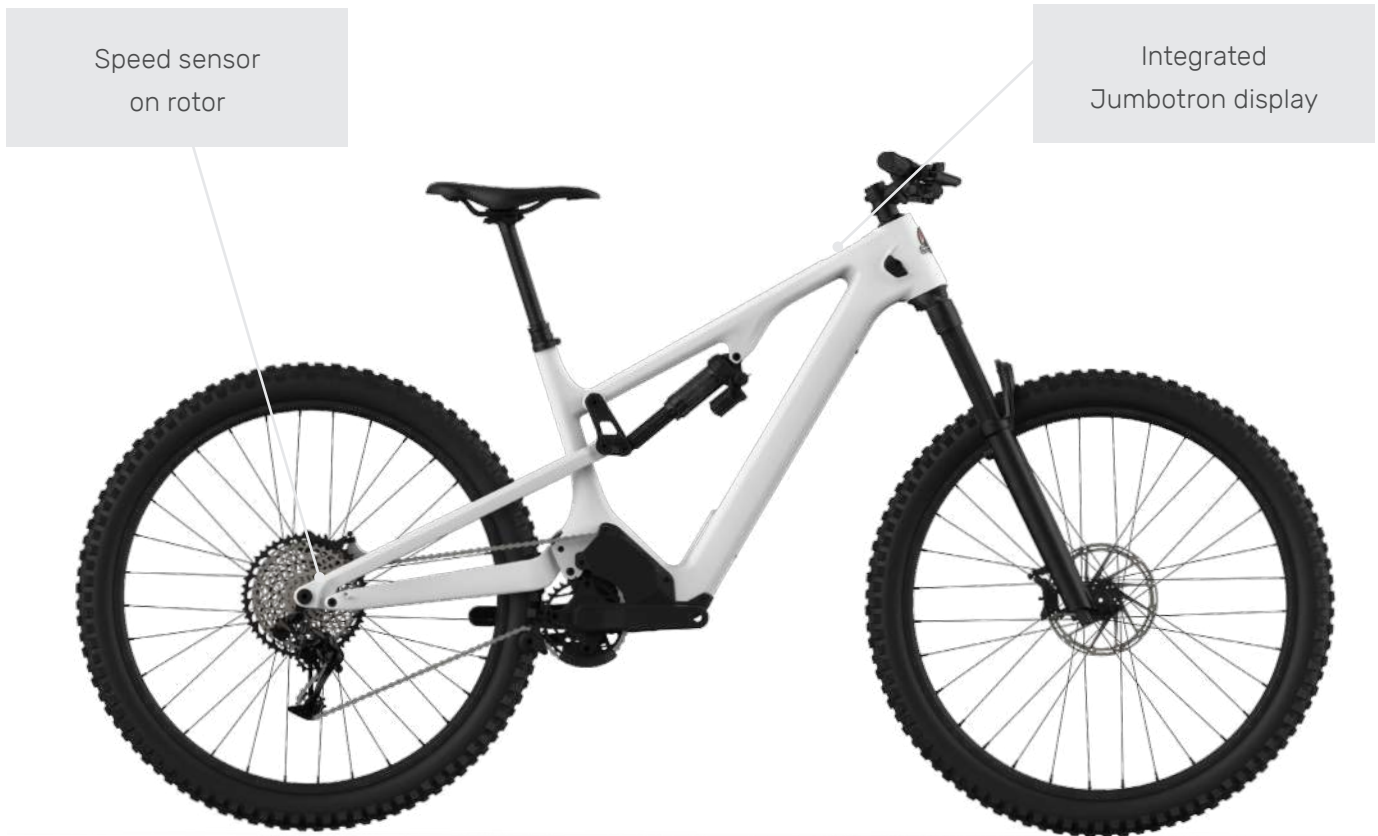

## JUMBOTRON

The Jumbotron display is the communication centre of your Powerplay™ bike. It serves to operate the system, display information and diagnose and repair issues. Firmware updates will be carried out through the USB module and computer as required.



## RIDER CONTROLS

### TMI (Thumb - Machine Interface, aka the remote)



## DISPLAY



## RIDING THE BIKE

### Warning

Make sure the brakes are applied before putting any pressure on the pedals, or even resting your foot on the pedals. The Powerplay™ Drive uses a sophisticated torque sensing circuit to deliver smooth, instant, natural feeling power. This circuit is very sensitive, so you must be careful to ensure the bike does not accelerate away from you when stopped.

### Power ON

To power up the Powerplay™ Drive, use the button on the Jumbotron to turn the bike on, by holding it for 2 seconds.

Note: The Powerplay™ Drive will always power up in the second lowest assistance mode. The rider can then increase the assistance using the remote, or the Jumbotron.

### Power levels

The Powerplay™ Drive provides several levels of power assistance:

#### Level 1: Eco

This is the lowest power setting, used for maximum battery life and rider input.

#### Level 2: Trail

This level balances assistance and battery life for all around trail riding .

#### Level 3: Trail+

This level gives the rider sufficient boost for an exciting ride, and good speed to get you to the downhills, without leaving the battery drained.

#### Level 4: Ludicrous

For maximum speed and assistance, this level delivers a huge amount of power to the rear wheel. Note that prolonged use of Ludicrous Mode will drain the battery relatively quickly.

To change assist levels, use the remote (up or down button) or click the button on the Jumbotron.

NOTE: THE RIDER CAN CUSTOMIZE BOTH THE POWER SETTINGS OF ALL 4 MODES, AS WELL AS THE MOTOR BOOST (TORQUE SENSITIVITY) IN THE MAIN MENU. HOLD  TO ACCESS.

### RIDING THE BIKE

The Dynamx S4 Lite system features an adjustable Kid Mode which allows you to set a speed and power limit on your Instinct Powerplay SL bike. To activate the KID MODE, hold the ⚡ button on the micro-remote and access the settings.

#### MENU Child Lock

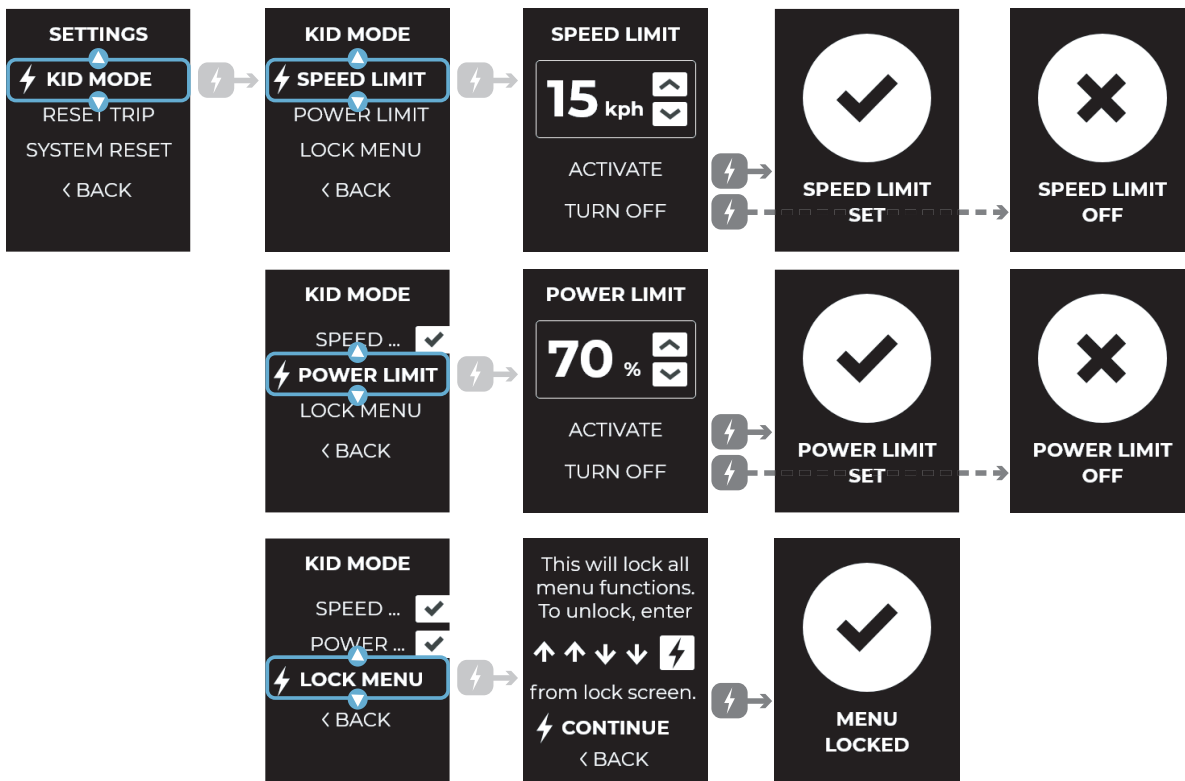

#### Once Locked



Pressing menu button brings up menu locked screen. \*Page times out after 5 seconds if no code is entered

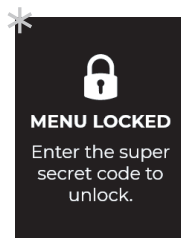

#### Unlock Sequence



If this sequence is entered, "menu unlocked" is displayed and normal menu functions return



## ASSISTANCE ADJUSTMENT

Assist levels can be adjusted at the start or at any time during the ride. The Dymene S4 Lite system can hold 3 different assistance maps in its memory: a default FACTORY map, and two customizable tunes. The rider can select between the maps depending on how they want the drive system to react.

### Select Tune

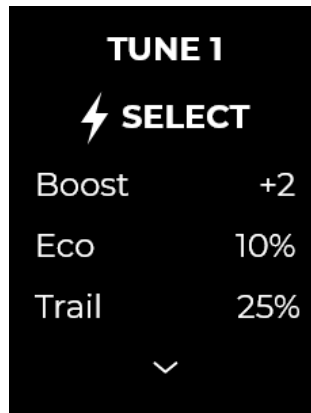
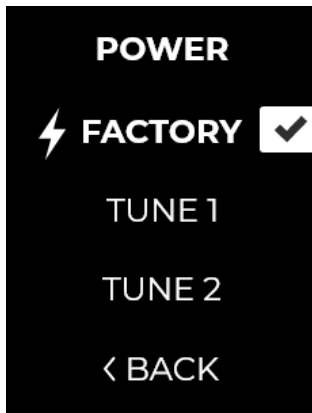

### Adjust Tune

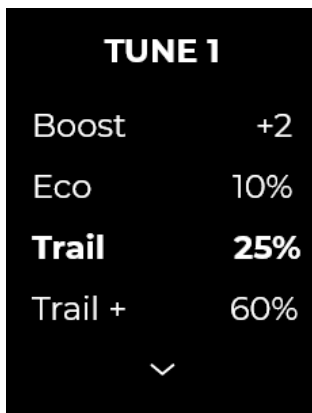
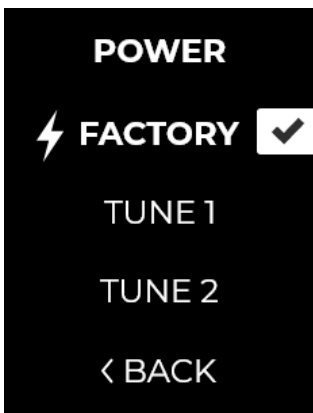

#### 2 adjustable parameters

•Boost: How the motor responds to rider input (torque sensitivity, or % boost)

•Assistance power: % of available power for each of the 4 assistance levels

## ASSISTANCE ADJUSTMENT

### Motor boost

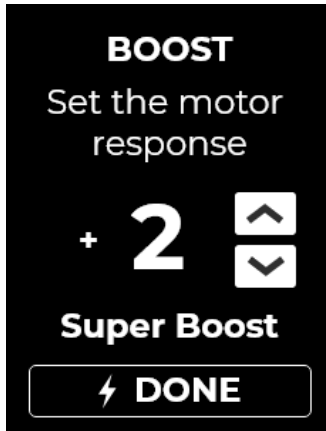

#### Adjust from +2 to -2

- +2** Very little effort required from the rider. Maximum boost, minimum battery range: BRAAAAAAP
- 0** Balanced performance, good response and battery range
- 2** Significant pedalling input required from rider, maximized battery range, best workout.

### Assistance power

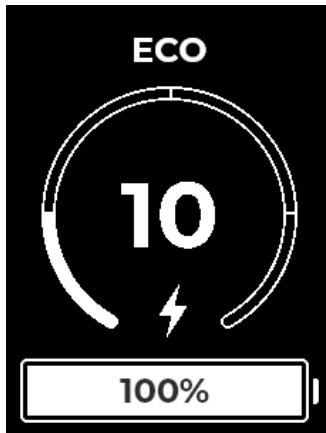

#### Adjust from 1% to 100%

For each of the 4 assistance modes (Eco, Trail, Trail +, Ludicrous), you can select the power output. It represents a percentage of the peak available power.

You cannot adjust the power of a high assistance mode to be lower than a lower assistance mode, e.g., Trail mode cannot be adjusted lower than Eco mode.

## BATTERY

The Instinct Powerplay SL features proprietary controls, motors, and battery components. Some of these components are sensitive and require extra care. We want to ensure that you have the most information possible. Please take note of the following updated details related to the Rocky Mountain Powerplay™ battery, recharging and care. Failure to follow the instructions and guidelines in this section may result in damage of electrical components on your bike and will void your warranty. More importantly, failure to follow the instructions may result in serious personal injury or death.

### General

- The batteries used in all Rocky Mountain Powerplay™ devices have all the required certifications and a Battery Management System (BMS) that provides multiple levels of fail-safes to prevent hazards. Despite these safety measures, a charged battery that has reached extreme temperatures or a charging port that has sustained damage can be dangerous, leading to electrical shock, fire, or injury.
- If your battery or charger shows any signs of damage, do not use it, and immediately bring your bike to your authorized Rocky Mountain retailer for inspection.
- The battery and drive unit, along with other proprietary Powerplay™ components, should only be serviced by mechanics that have gone through Rocky Mountain Powerplay™ training.
- Do not allow any small, sharp, and/or metallic objects to come in contact with the battery or the battery's recharging socket.
- Do not modify, open, or disassemble the battery or charger.
- Never clean an Powerplay™ with a high-pressure washer or submerge the bike in water. Rain and normal washing will not cause a problem.
- Undamaged batteries will not release fluids or gases. However, in the event of damage, battery fluid can cause skin irritation and burns, and battery gases can be released and irritate the airways. In the event of skin or eye contact with any fluids or gases from the battery, immediately flush with water and seek medical assistance.
- When transporting the bike on a car, if the battery is removed, ensure all connections are covered to avoid contamination from road grit, water and salt.
- If a battery fire occurs, do not attempt to directly extinguish it with water. You can use water to extinguish materials surrounding the battery, but not the chemical cells themselves. To properly extinguish a burning battery, use a Class ABC or BC fire extinguisher. Sand can also be used to smother the fire effectively. If possible, without exposing yourself to any personal risk of injury, bring any heated or ignited battery or complete bike outside to prevent the fire from spreading. If the battery is connected to a charger, the first action should be to unplug the charger or cut the power from the grid.

### Charging

- Only use the dedicated Powerplay™ chargers for any Powerplay™ battery.
- Do not leave the charger in direct sunlight, especially during recharging.

### To recharge the battery

1. Find the charge port on your Instinct Powerplay SL bike and open the recharging port cover.
2. Note the shape of the charging cable connector, and orient it correctly to the charge port on the bike.  
Connect the charger to the Powerplay™ bike.
3. Plug the charger into an electrical source. The LED on the charger will illuminate red to indicate charging .



### BATTERY

4. When the battery is nearing its full charge, it the system will slow the charging rate down to top up and balance the cells. The charger may alternate between "charging (red)" and "full (green)" led, at 30 second intervals, for 30 minutes. If the LED remains green for more than 5 minutes, the battery is fully charged. It is not necessary to disconnect the charger immediately after the recharge is complete; however you should not leave the bike connected to the charger for a period longer than 12 hours.

#### NOTES:

1. Do not confuse this end of charge situation with a system fault, which will trigger a rapid blinking of the charger.
  2. This end of charge state represents the final 3% of battery charging. You can disconnect the charger at any time if you are satisfied with the battery level.
- Recharge your Powerplay™ bike in an open area with clear access to an outside exit.
  - As with all bikes and equipment with lithium-ion batteries, it is recommended to only recharge the bike under supervision.
  - If the battery reaches 50 °C (122 °F), the recharge will be stopped until the battery temperature drop to 45 °C (113 °F). If the battery drop to 0 °C (32 °F), the recharge will be stopped until the battery temperature rises to 3 °C(37.4 °F).
  - Recharging time will vary depending on remaining energy in the battery.

• Recharging time is as follows:

480 Wh	4A Charger	2A Charger
Time to charge from 0–80%	1h55	4h00
Time to charge from 0–95%	2h20	4h40
Total charge time from 0–100%	2h35	5h05

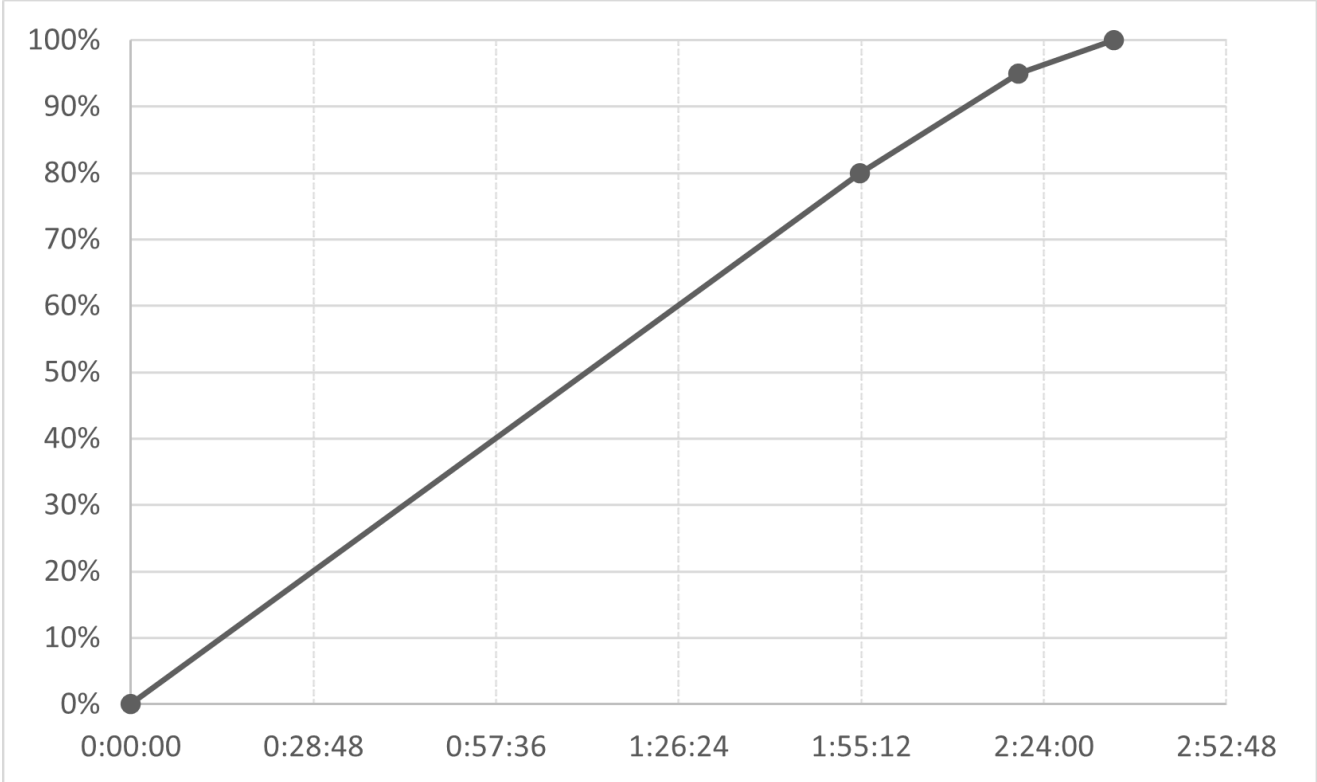

## BATTERY

### Storage

- To store your Instinct Powerplay SL bike, keep it in a secure place that is not exposed to extreme temperatures (above 30 °C (86 °F), or below -20 °C (-4 °F)), or excessive sunlight, humidity, or condensation. If you believe that the bike has been stored in the conditions listed above, please cease usage, and contact your authorized Rocky Mountain dealer.
- Storing a fully depleted battery for a prolonged period will cause damage and diminish its capacity. It is recommended to disconnect the battery prior to long term storage that exceeds 2 weeks. It is also recommended to recharge your battery to at least 75% capacity whenever possible, to avoid damage from deep discharge over prolonged periods and thereby voiding your warranty.
- If you store your bike for long periods of time, you must recharge the battery periodically, at least once every three months, to maintain its capacity. Failure to do so may cause damage to the battery, and a loss of its capacity. A good way to manage storage recharging is to set calendar reminders in your computer or mobile device.
- The best practice to maintain the optimum battery capacity over time is to store the bike at temperatures between 10 °C (50 °F) and 25 °C (77 °F) and relative humidity below 65%.
- After 1 month of storage, the battery will enter a protection mode. To revive the battery, please plug it to the charger.

### Battery functionality

- The battery will function in cold weather, though at a diminished capacity. Expect 70% of full capacity at -10 °C (14 °F). It is recommended to warm up a cold bike prior to use.
- If the battery reaches 65 °C (149 °F), it will shut itself down for protection until it drops below 60 °C (140 °F). If the battery reaches -20 °C (-4 °F), it will shut itself down for protection until it warms up to at least -15 °C (5 °F)
- When the remaining battery capacity is low, the Powerplay™ drive will progressively reduce power output to maximize its range.
- Please note that lithium-ion batteries gradually lose capacity depending on age and use. A dramatic decrease in capacity may be a sign that the battery is reaching the end of its lifespan and must be replaced. Please visit your authorized Rocky Mountain retailer for battery replacement. Under normal use, you can expect:

#### **480 Wh**

Will operate at 80% of full capacity after 500 full charging cycles (0% to 100% charge).

## BATTERY

### Battery LED

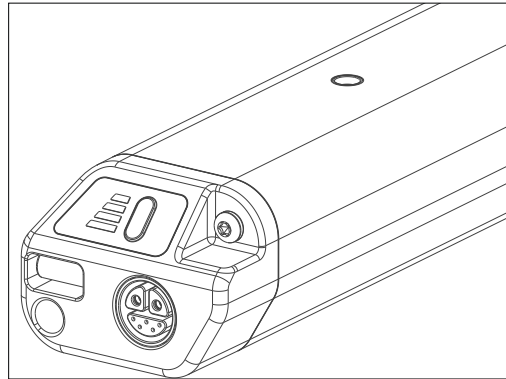

### Battery Level Indication

- **Fast press the capacity button**  
Press the capacity button less than 1 second when power on.

BATTERY CAPACITY LED INDICATION (LED 4,3,2,1)	Remaining battery charge
● ● ● ●	100%-75%
● ● ● ●	74,9%-50%
● ● ● ●	49,9%-25%
● ● ● ●	24,9%-0%

### During charging

- **Charging-in-progress Indication**

BATTERY CAPACITY LED INDICATION (LED 4,3,2,1)	Remaining battery charge
● ● ● ●	100%-75%
● ● ● ●	74,9%-50%
● ● ● ●	49,9%-25%
● ● ● ●	24,9%-0%

● : No light

● : Static light

● :Blinking

## RIDER SCREENS

Depending on the selection, the screen will display one type of information, while still showing critical data. This screen shows race appropriate information like speed, cadence, assist level and boost level, all on one screen.

### Race Screens

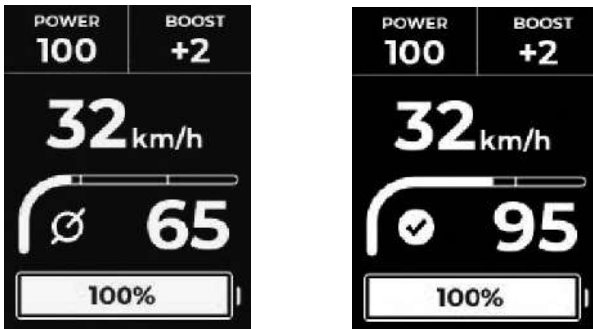

### Speed View

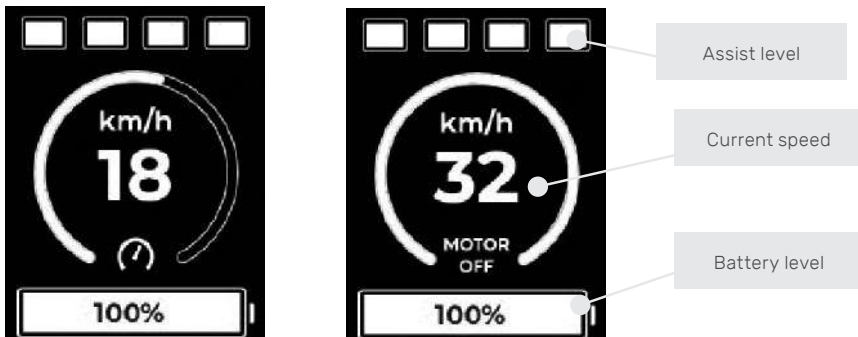

### Battery View

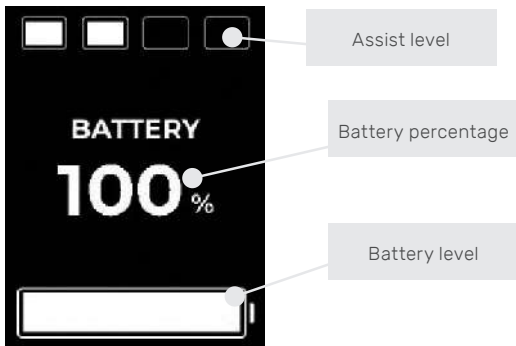

## RIDER SCREENS

### Assist View

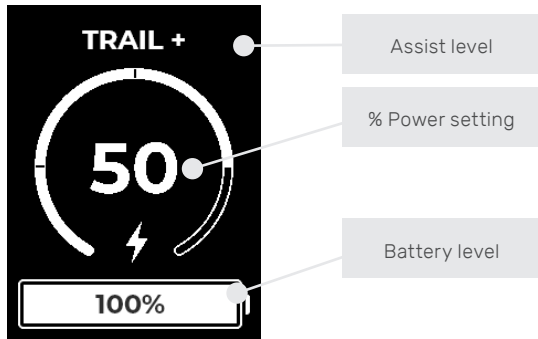

### Cadence View

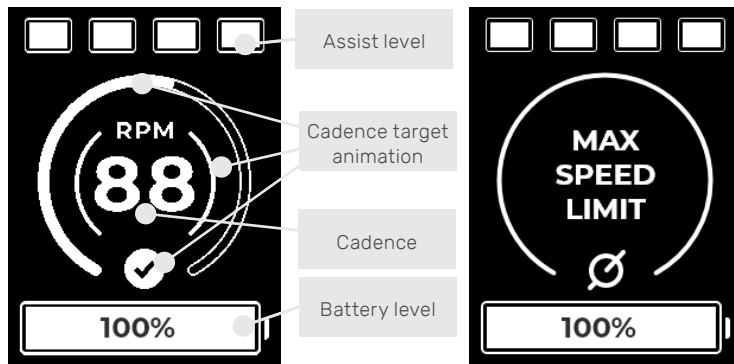

Note that cadence is interpreted through motor RPM, and is an estimate. That also means that when the motor is stopped (ex: above max speed), there is no cadence reading.

### Odo / Trip View

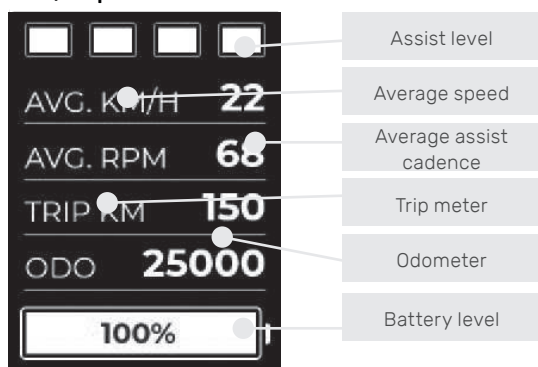

## RESET

The rider can always reset the trip information (average speed, average cadence, distance), as well as restore the Dynamex system to original factory settings.

### Trip reset

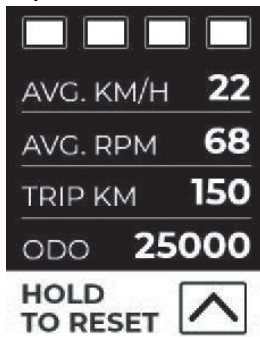

In the odometer view, hold the UP button on the TMI or

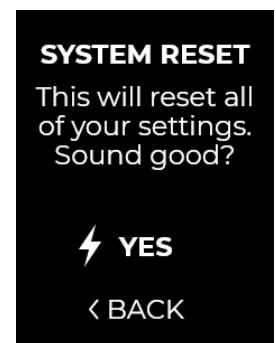
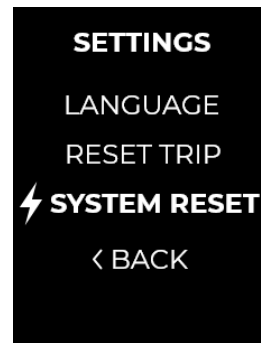

From any rider screen, enter the main menu by HOLDING ⚡. Go to Settings – System reset.

### Walk Mode

The Powerplay™ has a Walk Mode you can use should the need arise. The Powerplay™ Drive is able to assist the bike at a walking speed. On the remote, push and hold the Down button. The bike will slowly power up the climb as you push it.

⚠ The Walk Mode may not be used while a rider is on the bike. The Walk Mode may be used only when walking alongside the bike.

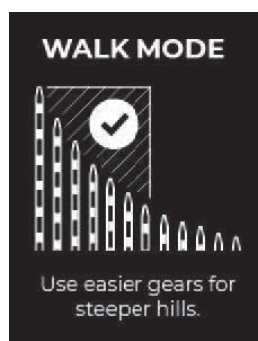

**Power OFF**

To power down the Powerplay™ Drive, hold the button on the Jumbotron. If the bike is left idle for 10 minutes, it will automatically shut itself off to conserve battery life.

**Prompt**

Appears after holding the Power button for 0.5 second.

**Shut Down**

Appears after holding the Power button for 2.5 seconds.

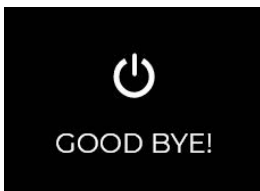
**NOTES****Damage to remote**

In the event the remote is damaged and stops working, the rider can continue to use the bike and cycle through the assist modes using the Jumbotron.

*NOTE: The menus and adjustments are not accessible via the Jumbotron, without the remote.*

**Range**

The distance over which the battery will power the drive system varies depending on several factors, such as assist level and boost mode selected, ambient temperature, acceleration, wind resistance, poor maintenance, battery age, hilly and rough terrain, and/or rider weight.

**Riding tips**

- The Dyname S4 Lite delivers smooth, natural feeling power to the rear wheel and works best under these circumstances.
- Use a smooth, consistent pedal stroke, rather than "mashing" the pedals.
- Shift often, to maintain a cadence between 80 and 120 RPM for optimal motor efficiency, yielding high torque and maximum battery performance. Use the cadence view on the Jumbotron, which informs the rider when they are pedalling in the efficient zone.
- When shifting gears, care should be taken:
  - Ease off pedalling pressure prior to shifting to avoid stressing the chain.
  - Do not shift multiple gears at once.

## SERVICE

### Diagnostics and repair

The Jumbotron can display error messages, as well as prompt the rider with instruction for repairing the system in some cases.

#### Example

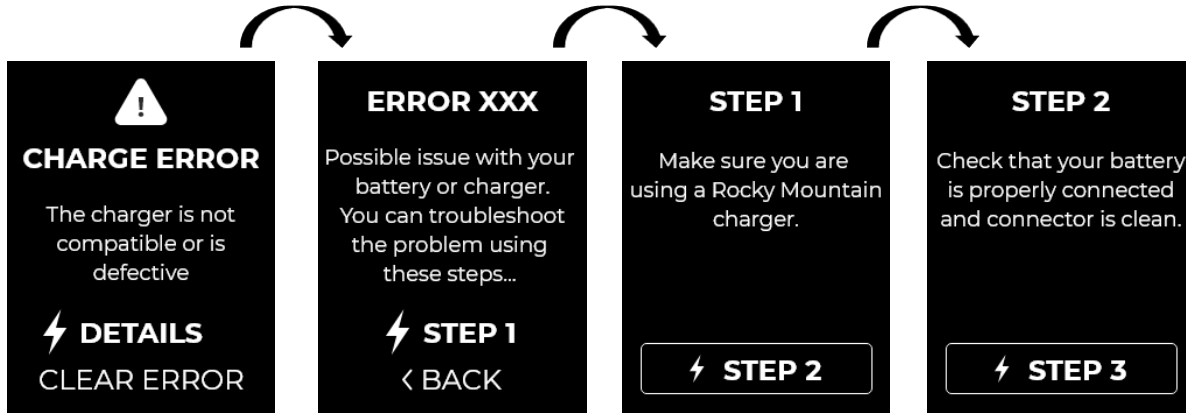

### Calibrating

A calibration procedure may occasionally be required to maintain the performance of the drive system. Typically this is done any time a drivetrain component is replaced (chain, chainring, drive pinion, etc) or the motor is reinstalled in the frame.

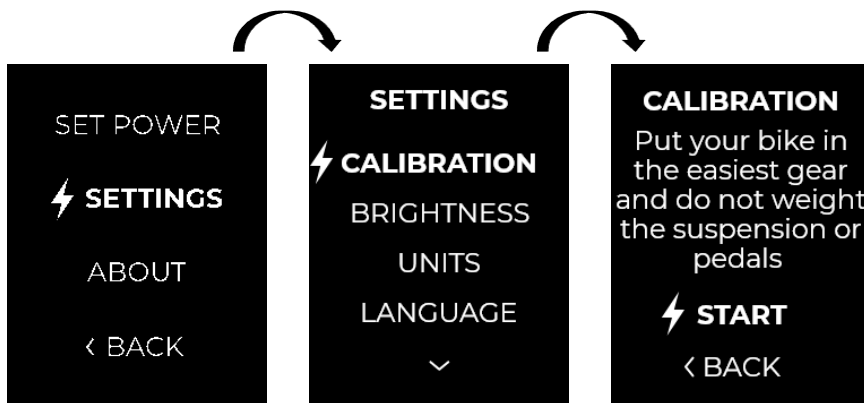

## SERVICE

### Troubleshooting

Please work with your local dealer for troubleshooting. Your Jumbotron display can generate error codes for diagnostics. When an error code appears, the system will prompt you with instructions. In some instances a field repair may be possible, in others, the rider may need to see an authorized dealer. Some errors will engage a limp mode, allowing the rider to return home at reduced power.

### Warning

**WARNING** – Do not tamper with your Rocky Mountain bicycle. Tampering is removing or replacing any original equipment or modifying your Rocky Mountain bicycle in any way that may change its design and/or operation. Such changes may seriously impair the handling, stability, and other aspects of the bicycle, making it unsafe to ride. Tampering can void the warranty and render your Rocky Mountain bicycle not in compliance with the applicable laws and regulations where the bicycle is being ridden. To ensure safety, quality, and reliability, use only original parts or Rocky Mountain Bicycles authorized replacements for repair and replacement. Rocky Mountain Bicycles is not responsible for any direct, incidental, or consequential damages, including, without limitation, damages for personal injury, property damage, or economic losses due to tampering.

#### *Attention:*

*The A-weighted emission sound pressure level at the driver ears is less than 70 dB[A].*



## GENERAL MAINTENANCE

Please note that electric assist bikes put more stress and strain on components than traditional mountain bikes. They should therefore be inspected and maintained more frequently to maximize safety, performance and longevity.

### Seasonal charging

If you store your bicycle for long periods of time, be sure to charge the battery at least once every three months. Failure to do so may cause damage to the battery, and a loss of capacity. After one month of storage, the battery will enter a protection mode. To revive the battery, plug it into the charger.

A good way to manage storage charging is to set calendar reminders in on your computer or mobile device.

### Cleaning

A clean bike is a happy bike. The best way to clean a dirty bike is with a bucket of warm , soapy water. Avoid using a pressure washer.

NOTE: Do not spray water at directly on any electrical component.

### Preventative maintenance

Clean and inspect drivetrain for wear

- Chain
- Cassette
- Pulleys (lower idler, derailleur pulleys)
- Chainring
- Drive pinion

Check bolts and fasteners

- All standard bicycle fasteners: pivots, stem, crank bolts, chainring bolts
- Motor mounts
- Torque sensor mount
- Battery retaining pin
- Check spoke tension
- Inspect brake pads & rotors
- Keep charge port clean / closed

## GENERAL MAINTENANCE

Periodic maintenance and adjustment checklist	Checklist					Notes
	500KM	1000KM	1500KM	2000KM	2500KM	
<b>Bicycle chain - inspect for wear, clean and lube</b>	Before each ride					Check condition (stretch, cracks) and lubricate with the chain supplier's recommended lubricant.
<b>Charge port</b>	Before each charge					Check for water intrusion, corrosion, pin alignment & dirt
<b>Torque sensor - calibration</b>	Bi-monthly					OR each time you replace a component of the drive system or drivetrain
<b>Motor mount screws</b>	●	●	●	●	●	Check for proper torque
<b>Drive pinion &amp; lockring</b>	●	●	●	●	●	Check condition; replace whenever worn to the limit
<b>Torque sensor &amp; idler pulley</b>	●	●	●	●	●	Check for cracks or damage
<b>Motor casing &amp; covers</b>		●		●		Check for cracks or damage
<b>Motor cables</b>		●		●		Check for insulation or connector damage
<b>Battery casing</b>	Inspect each time battery is out of the bike					Check for casing or connector damage
<b>Handlebar remote &amp; cable</b>	●	●	●	●	●	Check for casing or connector damage
<b>Toptube display &amp; cable</b>	●	●	●	●	●	Check for excessive play & screen damage
<b>Downtube extension cable</b>	●	●	●	●	●	Check for casing or connector damage
<b>Speed sensor &amp; cable</b>	Inspect each time wheel is off the bike					Check for casing or connector damage; ensure magnets are well secured
<b>Transfer chain - clean and lube</b>		●		●		Check condition and lubricate with the same oil used on the drivetrain chain
<b>Transfer chain - replace</b>	Replace every 2500KM					Check condition to avoid internal motor wear and noise
<b>Motor clutch bearing - replace</b>	Replace every 2500KM					Check bearing for smooth operation
<b>Spider clutch bearing - replace</b>	Replace every 2500KM					Check bearing for smooth operation

## **GENERAL MAINTENANCE**

### **REPLACEMENT PARTS AND ACCESSORIES**

Rocky Mountain replacement parts and accessories should be obtained through your local authorized Rocky Mountain Dealer. We highly recommend that you carry a spare inner tube and the required tools to undertake a tube replacement when you ride your bike.

### **TRANSPORTATION**

Rocky Mountain replacement parts and accessories should be obtained through your local authorized Rocky Mountain Dealer. We highly recommend that you carry a spare inner tube and the required tools to undertake a tube replacement when you ride your bike.

### **REGISTER**

Registering your bike is the official way for us to welcome you into the Rocky Mountain family. It's also an important step in activating your bike's warranty. If you ever have an issue, we'll be able to handle your case efficiently and get you back riding as soon as possible. It's easy and only takes a few minutes.

Register your bike: [bikes.com/register](https://bikes.com/register)

## WARRANTY INFORMATION

Your Rocky Mountain Instinct Powerplay SL is covered by warranty against defects in materials and manufacturing as per the following table:

CATEGORY	TERM	NOTES
Frame members	5 years	Front triangle + rear triangle, links
Hardware	1 year	Pivots, axles, etc.
Paint & decals	1 year	Pivots, axles, etc.
Rocky Mountain branded Carbon rim	2 years	2 year no fault replacement warranty for free, after 2 years it gets replaced for a fraction of the MSRP*. *The warranty does not cover labor costs & shipping cost
Electronics	3 years	Drive, Remote, Jumbotron, Sensors, Charger *The warranty does not cover labor costs & shipping cost
Drive wear items	1 year	Pulleys, pinions, transfer chain
Battery	24 Months	The Powerplay™ Drive will progressively reduce power output to maximize range, as the battery depletes. Range varies depending on several factors, such as assist level, ambient temperature, acceleration, wind resistance, poor maintenance, battery age, hilly and rough terrain and rider weight. If stored for more than 3 months, charge battery every 3 months. Failure to do so may cause damage & void warranty.
Components	As per original manufacturer warranty	

All warranty and after-sale service must be handled by the Authorized Rocky Mountain Dealer who sold the complete bicycle or frame. We cover your Rocky Mountain frame from the original date of purchase of your new bicycle against defects in material and workmanship, according to the frame material and the type of use made of the bicycle. Rocky Mountain's limited warranty also covers bicycles previously used for personal and commercial activity such as rental (including at bike parks), courier services, police, security, etc., against defects in material and workmanship.

The limited warranty applies for the remainder of the warranty period from the original date of purchase from Rocky Mountain. In such cases, hardware, bearings, pivots, and bushings are excluded from our warranty policy. The original sales receipt, bicycle registration confirmation or other proof of purchase is required for all claims.

For 2021 bikes and newer models, the original limited warranty is transferable to second-hand owners. For the limited warranty to apply, the registration of the bike must be done online both by the original owner and the second-hand owner. The original invoice will not be required for the second-hand owner.

### Please register the bike to transfer the warranty.

#### Frame material / Type of use

- Carbon fiber: 5 years - Limited\*
- Aluminum: 5 years - Limited\*
- Please refer to limitations stated below

#### Other warranty coverage against defects in workmanship and materials

- Coating - paint and decals: 1 year
- Frame hardware, suspension pivots, and bushings: 1 year

\*Links are part of the frame

[bikes.com/registration](https://bikes.com/registration)

## WARRANTY INFORMATION

### NOTE

#### Warranty is not valid in the following situations:

- Installation and use of components, parts, or accessories not originally intended for or compatible with the bicycle (or frame) as sold.
- Purchasing a Rocky Mountain Bicycle from an unauthorized dealer.
- Purchasing a Rocky Mountain Bicycle or frame off third party internet sites (as eBay), no matter what the listing says.
- Paint fading caused by the effects of ultraviolet light (UV) or outdoor exposure is not covered by this limited warranty.
- Rocky Mountain does not warrant against any damage caused to your bicycle during installation or removal of any protective film products.
- Scratches or chips in the paint caused by dirt, rocks, road debris, rack transport, etc., is not covered by this limited warranty.
- Damage to the Pressfit bottom bracket caused by improper service, materials or parts is not covered by the Rocky Mountain Limited Warranty.

#### Detail of what is not covered under warranty:

- A. Normal wear and tear on tires, tubes, brakes, gear cables, brake pads, bearings, etc., are not covered. Your authorized Rocky Mountain dealer will inform you of what these normal maintenance items consist of.
- B. Consequential damage or any damage caused by accident, misuse, or abuse.
- C. Improper assembly or lack of proper maintenance, sandblasting, sanding, grinding, wire brushing, filing, welding, brazing, drilling holes, anodizing, repainting, or chrome plating is not covered under our warranty and may void the warranty of the other components.
- D. You take great personal risk and shall forfeit the warranty, as outlined in the Warranty Table, when you ride in extreme terrain as depicted in mountain bike videos (ie. ride «trials» style courses, ride ramps, do stunts, ride on BMX tracks, ride in the city downstairs and embankments, or ride in other similar terrain). It is important to note that bent components, frames, forks, handlebars, seat posts, pedals, cranks, and wheel rims are signs of accidents or abuse.
- E. Labour for part replacement or changeover is not included.
- F. Rocky Mountain retains the right to repair or replace at its discretion any part that is deemed a valid warranty. Please note that Rocky Mountain will do all it can to ensure but cannot guarantee a colour match to the original component.

#### EXCLUSION AND LIMITATION OF DAMAGES

ROCKY MOUNTAIN'S WARRANTY IS LIMITED TO THE REPAIR OR REPLACEMENT OF THE PRODUCTS AND DOES NOT GRANT ANY WARRANTY EITHER EXPRESSED OR IMPLIED, LEGAL OR CONVENTIONAL AND DISCLAIMS ANY AND ALL IMPLIED WARRANTIES OF MERCHANTABILITY AND FITNESS FOR PARTICULAR PURPOSES AND ROCKY MOUNTAIN SHALL UNDER NO CIRCUMSTANCES BE LIABLE FOR DIRECT OR INDIRECT, SPECIAL, INCIDENTAL OR CONSEQUENTIAL DAMAGES EVEN WHEN ROCKY MOUNTAIN HAS BEEN ADVISED OF SUCH DAMAGES, AND ROCKY MOUNTAIN'S LIABILITY SHALL BE LIMITED TO \$50.00.

## DECLARATION OF CONFORMITY

We declare the following Powerplay™ equipped bicycle platforms are in conformity with relevant European Union harmonisation legislation.

Rocky Mountain Instinct Powerplay SL

For a complete list of models go to [www.bikes.com](http://www.bikes.com)

The products described above fulfill the requirements of the following directives:

- Machinery Directive 2006/42/EC
- EMC Directive 2014/30/EU
- RoHS Directive 2011/65/EU

The products have been designed and tested to fulfill the requirements of the following standards:

- EN15194:2017 : Electronically power assisted cycles – EPAC Bicycles
- ISO4210-2:2015 : Safety requirements and testing procedures for mountain bicycles
- IEC/EN 62133-2:2017 : Requirements and tests for the safe operation of portable sealed secondary lithium cells and batteries. Part 2: Lithium systems
- EN50604-1:2016 : Secondary lithium batteries for light EV (electric vehicle) applications - Part 1: General safety requirements and test methods

I, Pierre-Luc Lapointe, R&D Director – Propulsion, am designated to compile the technical file on behalf of the manufacturer Rocky Mountain, Division of Industries RAD inc.

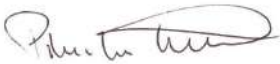

**Pierre-Luc Lapointe, ing.**  
**R&D Director – Propulsion**  
**9095 25th Avenue, St-George, Quebec, Canada**

### Authorized European representative:



**Carsten Bresser**  
**Managing Director, Bikeaction GmbH**  
**Weiskircher Str. 102, Rodgau, Germany**

### Manufacturer & EU Importer

Rocky Mountain  
 Division of Industries RAD inc.  
 9095, 25th Avenue  
 Saint-Georges, Qc,  
 Canada, G6A 1A1

### Switzerland

CHRIS Sports AG  
 Wittenwilerstrasse 12,  
 8355 Aadorf  
 Switzerland

### Norway

Vertical Playground AS  
 Ola Setroms Veg 17  
 7340 Oppdal  
 Norway

### Authorized European representative:

Bikeaction GmbH  
 Weiskircher Str. 102  
 63110 Rodgau  
 Germany

**(EU) 2023/1542 ARTICLE 10 PART A OF ANNEX IV**

Model Name	Rated capacity and capacity fade		Power and power fade *This value is for reference only.				Internal resistance and internal resistance increase *This value is for reference only.		The expected life-time of the battery under the reference conditions for which is has been designed
	Rated capacity (Ah)	Capacity fade (%)	Power (W)		Power fade (%)		Internal resistance ( $\Omega$ )	Internal resistance increase (%)	Under the cycles (times)
			Power capability		Power capability				
			at 80%	at 20%	at 80%	at 20%			
<b>1972002</b>	14.3	>25	680	581	93	92	>0.143	195	1000
<b>1972011</b>	8.8	>50	676	581	96	95	>0.133	109	500
<b>1974005</b>	4.75	>25	383	328	91	89	>0.330	199	1000
<b>1975006</b>	9.5	>25	731	626	91	90	>0.162	196	1000

## GUIDE DE DÉMARRAGE RAPIDE

### Fixation du Jumbotron

Conformément aux normes d'expédition, la source d'alimentation doit être déconnectée pour le transport. Retirez la vis qui maintient le Jumbotron en place et soulevez ce dernier. Trouvez le câble du tube diagonal (le câble vert) et connectez-le au câble vert du Jumbotron. Réinstallez le Jumbotron et fixez-le avec la vis.

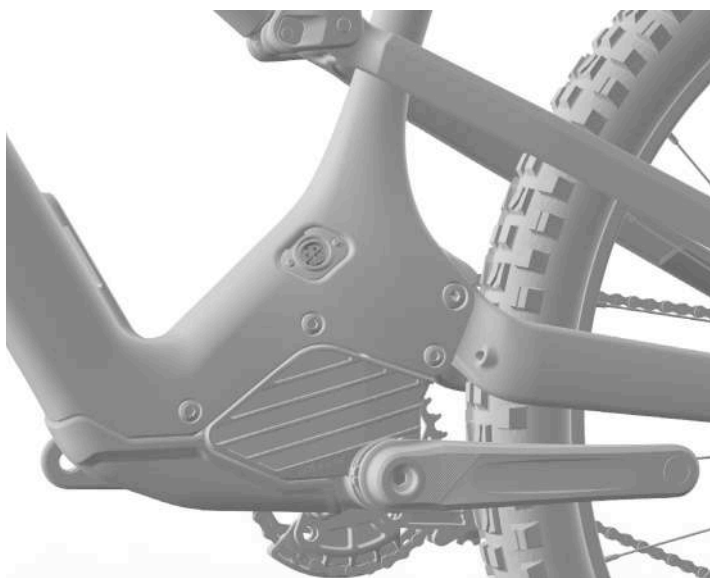

## GUIDE DE DÉMARRAGE RAPIDE

### Recharge de la batterie

Pour l'expédition, la batterie doit être chargée à environ 50 %. Veuillez recharger le vélo avant sa première utilisation.

PORTEZ ATTENTION AU SENS DE LA PRISE : un mauvais branchement peut causer des dommages permanents.



## GUIDE DE DÉMARRAGE RAPIDE

### Mise en marche du vélo

Pour mettre le vélo en marche, appuyez sur le bouton d'activation du Jumbotron pendant deux (2) secondes.

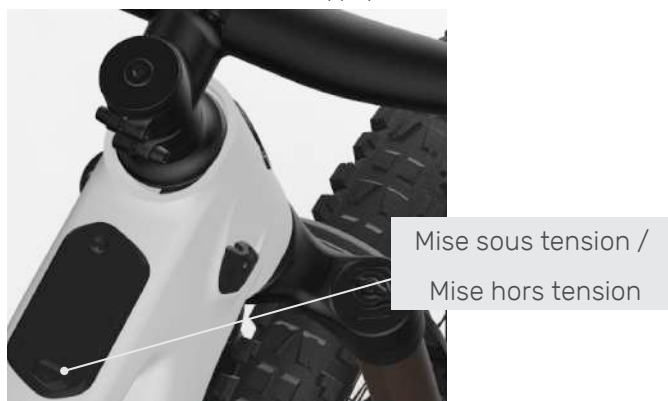

### Réglage des paramètres du vélo

À la toute première activation du vélo, l'utilisateur doit régler les paramètres. Pour passer cette étape et utiliser le vélo immédiatement, appuyez sur le bouton ⚡. À tout moment, vous pouvez ouvrir le menu principal en maintenant le bouton ⚡ enfoncé..

### Télécommande et boutons du Jumbotron



## GUIDE DE DÉMARRAGE RAPIDE

### Accéder au menu

À tout moment, vous pouvez ouvrir le menu principal en maintenant le bouton ⚡ enfoncé. Appuyez sur le bouton de retour en arrière ou maintenez le bouton ⚡ enfoncé pour quitter ce menu.

### Accéder aux diagnostics

À tout moment, vous pouvez ouvrir le menu de diagnostic en maintenant les boutons et « Haut ». Appuyez sur le bouton de retour en arrière ou maintenez le bouton ⚡ enfoncé pour quitter ce menu.

### Naviguer dans un menu

Lorsque vous êtes dans un menu, vous pouvez naviguer en utilisant les boutons « Haut » et « Bas » du degré d'assistance, et le bouton pour confirmer les commandes. Appuyez sur le bouton de retour en arrière ou maintenez le bouton ⚡ enfoncé pour revenir quitter ce menu.

### Étalonnage dans les 100 km

Le système Dyname S4 Lite mesure la tension de la chaîne pour déterminer la puissance du rider. Au fil de l'utilisation de la nouvelle transmission, il est toujours recommandé d'étalonner le système après environ 75 km (45 mi) parcourus. Maintenez le bouton ⚡ enfoncé pour ouvrir le menu principal, sélectionnez l'option d'étalonnage, puis suivez les instructions.

### ATTENTION!

#### KID MODE

Ce vélo électrique est équipé d'un limiteur de vitesse et de puissance, ainsi que d'un verrouillage de menu pour enfants. Veuillez consulter la section UTILISATION DU VÉLO de ce manuel pour plus d'informations sur comment activer et ajuster ces fonctions.

[Ajouter image du Jumbotron qui montre le KID MODE]

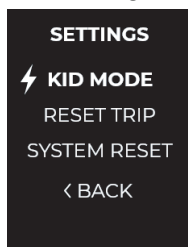

### Lire le guide

Enfin, et surtout, lisez le reste de ce manuel ou trouvez-le en ligne au <https://support.bikes.com/support/home>.

## INTRODUCTION

Votre Instinct, électrifié. L'Instinct Powerplay™ SL a du punch dans un ensemble léger. Alimenté par notre tout nouveau système d'entraînement Dynamé S4 Lite, nous avons conçu un vélo qui se conduit comme un vélo de trail, mais avec la puissance nécessaire pour explorer plus loin que jamais. Construit autour de notre système de suspension à pivot moyen-haut, le cadre a fait l'objet d'une révision complète avec une géométrie et une cinématique de suspension mises à jour, améliorant les sensations de conduite et offrant de nombreux réglages du cadre.

Ce manuel contient des informations importantes sur la sécurité, l'entretien et l'utilisation. Veuillez à le lire attentivement et à bien le comprendre avant votre première sortie sur votre nouveau vélo Rocky Mountain Instinct Powerplay™ SL. Ce document ne s'applique qu'à la plate-forme spécifique que vous avez choisie et doit être utilisé conjointement avec le manuel du propriétaire Rocky Mountain, qui est fourni avec votre vélo. Veuillez lire le manuel du propriétaire avant votre première sortie. Si vous ne disposez pas d'un exemplaire du manuel du propriétaire, vous pouvez l'obtenir auprès du revendeur agréé Rocky Mountain le plus proche ou en ligne, sur la page produit de votre modèle de vélo.

## ÉTIQUETTE DE LA MONTAGNE

### Courtoisie

Faites toujours preuve de courtoisie envers les autres utilisateurs des sentiers. La prudence est particulièrement importante en présence d'animaux domestiques comme des chiens ou des chevaux. Cédez toujours le passage aux autres utilisateurs, en montée comme en descente.

Les modèles Instinct Powerplay™ SL sont conçus pour la conduite en sentier en zone autorisée. Faits pour les terrains difficiles qui comportent des sauts modérés et des portions techniques, ils ne conviennent toutefois pas à des sentiers et terrains extrêmes (notamment ceux de type dirt, freeride, descente ou North Shore intenses). Ils ne sont pas conçus pour les grandes ruptures de pente, les descentes accidentées à plus de 40 km/h (25 mi/h), les sauts importants ou les descentes de structures en bois, ni les modules comportant des atterrissages raides et des obstacles difficiles.

### Sentiers

N'utilisez votre vélo Powerplay™ que sur des sentiers où l'usage de véhicules motorisés est permis. Respectez la réglementation locale. Comme tous les utilisateurs, vous devez veiller à limiter les répercussions de votre passage sur les sentiers et l'environnement. Évitez les dérapages et ne modifiez pas les sentiers.

### Voies publiques

Avant d'enfourcher votre Instinct Powerplay SL de Rocky Mountain, informez-vous de la réglementation en vigueur dans votre pays et votre État ou province. Des restrictions peuvent s'appliquer à l'utilisation d'un vélo Powerplay™ sur la voie publique, les pistes cyclables ou les sentiers. Il peut aussi y avoir des exigences concernant le port du casque, l'utilisation de lumières, l'âge minimum, l'obtention d'un permis ou la souscription à une assurance. Rocky Mountain n'offre et n'offrira aucune promesse, représentation, ni garantie concernant l'utilisation de votre vélo Powerplay™. Comme la réglementation encadrant les vélos électriques évolue constamment et varie d'un pays et d'une province ou d'un État à l'autre, assurez-vous d'obtenir l'information la plus récente. Vous devriez également consulter régulièrement votre détaillant Rocky Mountain Bicycles autorisé pour avoir l'information à jour.

### Visibilité et Sécurité

Avant d'utiliser votre vélo Rocky Mountain Powerplay, veuillez-vous assurer que tout équipement de visibilité et de sécurité inclus avec votre vélo Powerplay soient installés sur celui-ci afin de garantir la conformité aux obligations légales ou des règles en vigueur dans votre pays, État ou province.

Si une clochette est incluse avec votre vélo Rocky Mountain Powerplay (France, Royaume-Uni, Australie et Nouvelle-Zélande), il est obligatoire de la faire installer sur votre vélo Powerplay avant son utilisation.

## AVERTISSEMENTS

### Puissance

Votre vélo Powerplay<sup>MC</sup> est doté d'une fonction de pédalage assisté puissante. Habituez-vous à son fonctionnement et à celui de la fonction d'assistance sur un terrain plat et sécuritaire avant de vous aventurer hors route.

### Démarrage instantané

Le vélo Powerplay<sup>MC</sup> est équipé d'une technologie de démarrage instantané qui lui donne une puissance immédiate, naturelle et tout en douceur grâce à un capteur de couple perfectionné. Ce circuit étant très sensible, vous devez prendre des précautions pour éviter que le vélo n'avance de façon inattendue ou incontrôlée.

### Prudence dans les sentiers

Votre vélo Powerplay<sup>MC</sup> accélère plus rapidement que les vélos traditionnels et doit être manoeuvré différemment. C'est pourquoi vous devez faire preuve de prudence dans les sentiers et tenir compte de ses caractéristiques de maniabilité et d'accélération uniques.

### Attention aux doigts

N'approchez pas vos doigts ou des outils du mécanisme d'entraînement. L'entretien et la réparation de ce mécanisme doivent être effectués uniquement par un centre de service autorisé de Rocky Mountain.



### Modification interdite

Ne modifiez ni le mécanisme d'entraînement Powerplay<sup>MC</sup> ni aucune pièce y étant directement connectée. Seul un centre de service autorisé de Rocky Mountain devrait procéder à l'entretien et à la réparation de ce mécanisme. Toute tentative de modification peut entraîner des blessures graves, voire mortelles, et annule automatiquement la garantie du vélo.

## AVERTISSEMENTS

N'attachez pas un porte-bébé, une remorque ou un accessoire semblable à une pièce ou à un composant en matériau composite ou en fibre de carbone, que ce soit directement ou indirectement. Par exemple, n'attachez pas une remorque en matériau composite ou en fibre de carbone à un axe arrière. De même, n'attachez pas une remorque à une tige de selle en fibre de carbone ou en matériau composite, ni un porte-bébé à une fourche de cette même composition. Dans les deux cas, vous risqueriez d'appliquer une tension inhabituelle sur le cadre ou le composant de votre vélo. Les dommages ou bris qui en résulteraient pourraient causer des blessures graves, voire la mort. Si vous avez déjà attaché un accessoire à une pièce ou à un composant en matériau composite ou en fibre de verre de votre vélo, ne l'utilisez pas avant de l'avoir fait dûment inspecter par votre détaillant Rocky Mountain autorisé. Avant de transporter des enfants sur votre vélo, prenez connaissance de la réglementation en vigueur dans votre pays et votre province ou État. Des restrictions peuvent s'appliquer à l'utilisation d'accessoires, notamment pour les vélos électriques ou à assistance électrique.

### Avertissements 1

Comme tout élément mécanique, un vélo à assistance électrique est sujet à l'usure et à de fortes contraintes. Les différents matériaux et composants peuvent y réagir différemment. Au-delà de leur durée de vie utile, les composants peuvent soudainement faire défaut et causer par le fait même des blessures. La présence de tout type de fissure, d'égratignure ou de décoloration à un point soumis à de fortes contraintes indique que le composant en question est en fin de vie et doit être remplacé.

### Avertissements 2

Comme les dommages d'une collision aux composants en matériau composite peuvent être impossibles à détecter pour l'utilisateur, c'est au fabricant qu'il incombe d'expliquer les risques qui s'y rattachent. En cas de collision, les composants en matériau composite doivent être retournés au fabricant pour inspection ou être détruits et remplacés.

### Avertissements 3

Ne pas laisser le vélo au soleil ou à la chaleur excessive de manière prolongée (intérieur d'une voiture stationnée ou proximité d'une source de chaleur comme un radiateur). Une chaleur excessive peut dégrader les matériaux des pièces et des composants, comme les batteries, les pièces en composite (guidon, manivelle et autres) et divers éléments en plastique qui contribuent à l'intégrité des vélos.

### Avertissements 4

La charge utile totale maximale autorisée (pilote, bagages et poids à vide de l'EPAC) est de 130 kg pour l'Instinct Powerplay SL en carbone et de 140 kg pour la version en aluminium.

### Avertissements 5

Le non-respect des avertissements de cette section peut endommager les composants de votre vélo, annuler la garantie et, surtout, entraîner des blessures graves, voire la mort. Si votre vélo présente des signes de dommages, ne l'utilisez pas et apportez-le immédiatement à votre détaillant Rocky Mountain Bicycles pour une inspection.

### Avertissements 6

Un accident ou un problème d'assemblage peut compromettre le guidon et les commandes du guidon et empêcher un contrôle et un freinage sécuritaires.

### Avertissements 7

Ne jamais gonfler un pneu au-delà de la plus basse des deux valeurs de pression maximale indiquées sur le flanc du pneu et au-delà de la pression maximale indiquée sur la jante. Si le pneu est gonflé au-delà de la pression recommandée, il risque de se détacher de la jante, ce qui pourrait endommager le vélo et causer des blessures au cycliste et aux gens autour.

## SURVOL DE VOTRE VÉLO



### CARACTÉRISTIQUES TECHNIQUES

- L'Instinct Powerplay™ SL est construit autour de notre tout nouveau système d'entraînement Dynamé S4 Lite. Doté d'un tout nouveau design de cadre avec de nouveaux profils de tubes, le cadre de l'Instinct Powerplay SL est plus léger et offre plus de possibilités d'ajustement que son prédécesseur, pour une meilleure adaptation au cycliste.
- La nouvelle unité d'entraînement Dynamé S4 Lite vous permettra de grimper les côtes avec un couple maximal de 65 Nm et une puissance maximale de 550 watts. A une cadence de 80 RPM, le moteur peut offrir jusqu'à 500 Watts de puissance, quand vous en avez besoin.
- Construit autour de notre capteur de couple externe breveté, le système Dynamé S4 Lite lit la tension qui est appliquée directement à la chaîne et supprime le temps de latence indésirable pour donner une réponse instantanée et naturelle lorsque la puissance est appliquée. Équipé de notre toute nouvelle batterie légère et mince de 480 Wh, le nouveau système Dynamé S4 Lite offre plus de 90 % de l'autonomie et de la verticalité qu'offre notre système Dynamé 4.0 (tests effectués en mode Ludicrous, Boost +2).
- Dynamé S4 Lite est équipé d'un écran d'affichage Jumbotron, parfaitement intégré dans le tube supérieur pour afficher toutes les données et informations clés dans un endroit pratique et facile à voir. Les écrans peuvent être parcourus à l'aide de la télécommande du guidon ou des boutons du Jumbotron lui-même.
- La cinématique Mid-High Pivot révisée se caractérise par une sensibilité associée à un soutien accru sur l'ensemble du débattement, dans le but d'améliorer le soutien et le confort sur les courtes comme sur les longues randonnées. .
- Proposé dans une large gamme de tailles de cadre et de roues. Le cadre XS est équipé de roues avant et arrière de 27,5". Les cadres SM-MD-LG-XL sont équipés de roues avant et arrière de 29". Ces tailles sont également compatibles avec l'utilisation d'une suspension MX spécifique.
- Le système de réglage RIDE-4™ permet aux cyclistes d'affiner rapidement leur géométrie à l'aide d'une simple clé Allen.
- Tous les cadres sont équipés d'un jeu de direction permettant d'ajuster la portée. Le cadre est équipé d'un jeu de direction 0mm / neutre. Dans la petite boîte de pièces jointe à chaque cadre et à chaque vélo complet, il y a un jeu supplémentaire de cuvettes de jeu de direction de 5 mm qui peut être utilisé pour ajuster la portée.
- Les roulements scellés au niveau de l'œillet d'amortisseur améliorent considérablement la sensibilité de l'amortisseur (compatible avec les amortisseurs du marché secondaire), tandis que les protections des roulements sur l'ensemble du cadre permettent d'éviter toute contamination sur les sentiers accidentés ou dans les stations de lavage après la course.
- Notre suspension Smoothlink est dotée de roulements communs, faciles à entretenir, associés à une conception de pivot durable.
- Le routage interne entièrement fermé sur nos modèles en carbone et en alliage, grâce à notre manchon guide-câble intégré, permet une installation facile des câbles et des durites, y compris pour les configurations de freinage de type motocyclette.
- Les cadres sont dotés d'une protection étendue en caoutchouc afin de réduire le bruit et d'éviter l'abrasion par contact.

## GÉOMÉTRIE ET TAILLE

L'Instinct Powerplay™ SL est une conception de cadre spécifique à la taille qui comporte de nombreux détails qui améliorent l'ajustement et la géométrie pour chaque cycliste.

### Taille des roues

- Le cadre XS est équipé de roues de 27,5 pouces à l'avant et à l'arrière.
- Le cadre XS n'est pas compatible avec les roues de 29", ni avec le MX.
- Les modèles SM, MD, LG et XL sont équipés de roues de 29 pouces à l'avant et à l'arrière.
- Les modèles SM, MD, LG et XL sont compatibles avec les modèles Mullet/MX en remplaçant la tringlerie de suspension.

### Casques réglables en hauteur

Tous les cadres sont équipés d'un jeu de direction permettant d'ajuster la portée. Le cadre est équipé d'un jeu de direction 0mm / neutre. Dans la petite boîte de pièces jointe à chaque cadre et vélo complet, il y a un jeu supplémentaire de coupelles de jeu de direction de 5 mm qui peut être utilisé pour faire des ajustements de portée. Lorsque vous consultez le tableau de géométrie avec les coupelles de 5 mm installées, il vous suffit d'ajouter ou de soustraire 5 mm aux mesures de portée, de longueur du tube supérieur et d'empattement pour les faire correspondre à l'orientation des coupelles. Pour les instructions d'installation, veuillez consulter la section Caractéristiques du cadre.

Jeu de direction en carbone 0mm



Jeu de direction en carbone 5mm



Jeu de direction en alliage 0mm



Jeu de direction en alliage 5mm



### Taille de cadre

Ce tableau est fourni à titre indicatif seulement. Pour choisir la bonne taille de vélo, il faut aussi tenir compte des proportions, du style de conduite et des préférences personnelles du rider. Rocky Mountain recommande toujours d'essayer le vélo et de le faire ajuster par un professionnel chez un détaillant autorisé.

CM	147.5	150	152.5	152.5	155	157.5	160	162.5	165	167.5	170	172.5	175	177.5	180	183	185.5	188	190.5	193	195.5	198
FT-IN	4'7"	4'8"	4'9"	5'0"	5'1"	5'2"	5'3"	5'4"	5'5"	5'6"	5'7"	5'8"	5'9"	5'10"	5'11"	6'	6'1"	6'2"	6'3"	6'4"	6'5"	6'6"
	XS			SM			MD			LG			XL									
XS	[Red bar]																					
SM						[Red bar]																
MD											[Red bar]											
LG																[Red bar]						
XL																			[Red bar]			

## GÉOMÉTRIE ET TAILLE

### RIDE-4

Grâce au système d'ajustement RIDE-4<sup>MC</sup>, le rider peut régler la géométrie avec précision et rapidité au moyen d'une simple clé hexagonale de 5 mm. Ce système est muni de deux plaques pivotantes permettant quatre configurations. Consulter le tableau des géométries pour savoir comment chaque position modifie la géométrie. Pour les instructions d'ajustement, consulter la section « Caractéristiques du cadre ».

#### Prêt pour n'importe quel sentier

Le système de réglage RIDE-4<sup>TM</sup> vous permet d'affiner rapidement votre géométrie et votre suspension avec une seule clé Allen de 5 mm.

PLUS RAIDE  
ANGLE DU TUBE DE  
DIRECTION  
SUSPENSION  
MOINS  
PROGRESSIVE

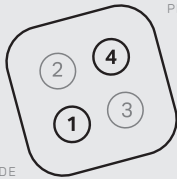

FLÉAU  
ANGLE DU TUBE DE  
DIRECTION  
UNE SUSPENSION  
PLUS PROGRESSIVE

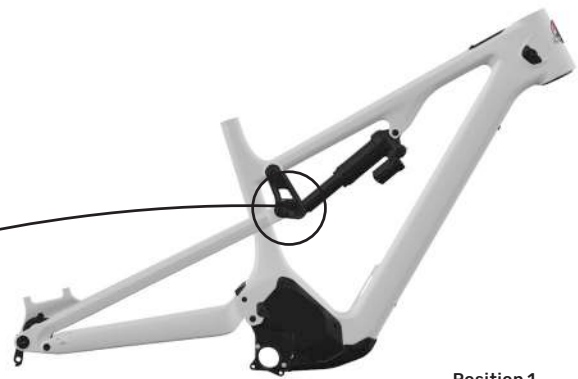
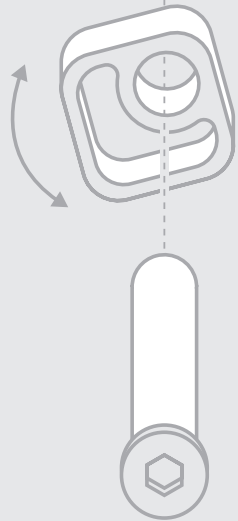

#### Position 1



SLACK

Le boîtier de pédalier plus bas et la suspension progressive augmentent la stabilité à des vitesses plus élevées. Recommandé pour les randonnées plus agressives.

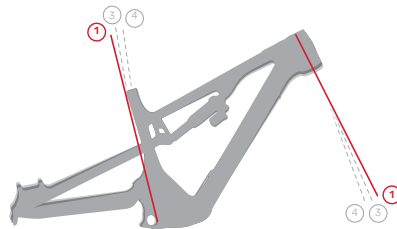

#### Position 3



NEUTRE

Cette position offre un mélange équilibré de géométrie et de performances de suspension pour répondre à une grande variété de pistes.

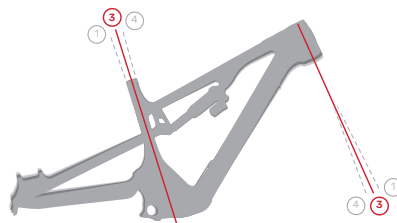

#### Position 4



STEEP

Le pédalier plus haut et la suspension linéaire permettent un meilleur dégagement des pédales, un taux de suspension initial plus favorable et une position sur le vélo plus adaptée à la montée.

## GÉOMÉTRIE ET TAILLES

TAILLE DE CADRE	XS	SM	MD	LG	XL
<b>Tailles des roues</b>	<b>27.5</b>			<b>29</b>	
Angle du tube de direction (degrés)	63.5	63.5	63.5	63.5	63.5
Angle du tube de selle (degrés)	76.4	77.0	76.5	76.5	76.5
Longueur du tube de selle (mm)	355.0	365.0	410.0	440.0	470.0
Longueur du tube horizontal (mm)	542.0	567.0	599.0	627.0	659.0
Longueur du tube de direction (mm)	105.0	105.0	110.0	125.0	135.0
Longueur de la base arrière (mm)	433.0	442.0	442.0	452.0	452.0
Hauteur du boîtier de pédalier (mm)					
Hauteur de surplomb (mm)	775.0	785.0	809.0	808.0	807.0
Empattement (mm)	1157.0	1205.0	1232.0	1274.0	1308.0
Portée (mm)	399.0	425.0	450.0	475.0	505.0
Élévation (mm)	590.0	618.0	622.0	636.0	645.0
Angle du tube de direction (degrés)	63.7	63.7	63.7	63.7	63.7
Angle du tube de selle (degrés)	76.6	77.2	76.7	76.7	76.7
Longueur du tube de selle (mm)	355.0	365.0	410.0	440.0	470.0
Longueur du tube horizontal (mm)	541.0	567.0	599.0	627.0	659.0
Longueur du tube de direction (mm)	105.0	105.0	110.0	125.0	135.0
Longueur de la base arrière (mm)	430.0	440.0	440.0	450.0	450.0
Hauteur du boîtier de pédalier (mm)					
Hauteur de surplomb (mm)	780.0	790.0	813.0	813.0	813.0
Empattement (mm)	1154.0	1203.0	1230.0	1272.0	1306.0
Portée (mm)	405.0	430.0	455.0	480.0	510.0
Élévation (mm)	586.0	614.0	618.0	632.0	641.0

## GÉOMÉTRIE ET TAILLES

TAILLE DE CADRE		XS	SM	MD	LG	XL
<b>Tailles des roues</b>		<b>27.5</b>			<b>29</b>	
Angle du tube de direction (degrés)		64.0	64.0	64.0	64.0	64.0
Angle du tube de selle (degrés)		77.0	77.5	77.0	77.0	77.0
Longueur du tube de selle (mm)		355.0	365.0	410.0	440.0	470.0
Longueur du tube horizontal (mm)		540.0	566.0	598.0	626.0	658.0
Longueur du tube de direction (mm)		105.0	105.0	110.0	125.0	135.0
Longueur de la base arrière (mm)	Position 3 Neutre	430.0	440.0	440.0	450.0	450.0
Hauteur du boîtier de pédalier (mm)		17.0	32.0	32.0	32.0	32.0
Hauteur de surplomb (mm)		780.0	790.0	813.0	813.0	813.0
Empattement (mm)		1154.0	1203.0	1230.0	1272.0	1306.0
Portée (mm)		405.0	430.0	455.0	480.0	510.0
Élévation (mm)		586.0	614.0	618.0	632.0	641.0
Angle du tube de direction (degrés)		64.2	64.2	64.2	64.2	64.2
Angle du tube de selle (degrés)		77.2	77.7	77.2	77.2	77.2
Longueur du tube de selle (mm)		355.0	365.0	410.0	440.0	470.0
Longueur du tube horizontal (mm)		540.0	566.0	597.0	625.0	657.0
Longueur du tube de direction (mm)		105.0	105.0	110.0	125.0	135.0
Longueur de la base arrière (mm)	Position 4 Ferme	429.0	439.0	439.0	449.0	449.0
Hauteur du boîtier de pédalier (mm)		14.1	29.2	29.1	29.1	29.0
Hauteur de surplomb (mm)		782.0	792.0	816.0	815.0	815.0
Empattement (mm)		1153.0	1202.0	1229.0	1271.0	1305.0
Portée (mm)		407.0	432.0	457.0	482.0	512.0
Élévation (mm)		585.0	612.0	617.0	630.0	639.0

## AJUSTEMENT DES TIGES DE SELLE TÉLESCOPIQUES

Les tiges de selle télescopiques jouent un rôle important dans l'ajustement et le confort des vélos. Vous trouverez ci-dessous les dimensions et mesures critiques qui vous guideront dans la configuration de la tige originale, ainsi que certaines des options possibles si une nouvelle tige de selle télescopique est installée.

Le tableau montre l'ajustement de la tige de selle lorsque le débattement de la tige de selle est complètement allongé. Cela vous permet de déterminer la position la plus basse ou la plus haute à laquelle votre tige de selle peut être réglée pour obtenir une hauteur correcte en position assise de pédalage. Le tableau vous aidera également à déterminer la taille de la tige de selle à installer si celle de l'équipementier n'est pas de la taille souhaitée. Veuillez noter que la dimension indiquée va du centre du boîtier de pédalier au sommet de la selle d'origine. La longueur du pédalier peut influencer l'ajustement de la selle et doit également être prise en compte en cas de changement de ce composant.

Comment utiliser le tableau :

1. Mesurez la hauteur actuelle de votre selle depuis le centre du pédalier jusqu'au sommet de la selle, juste au-dessus de la tige de selle.
2. Choisissez le modèle de tige de selle, le débattement et le cadre que vous souhaitez.
3. Assurez-vous que votre mesure se situe entre les longueurs d'insertion minimale et maximale indiquées dans le tableau.

Exemple : J'ai mesuré 795 mm sur mon vélo actuel. Si je choisis une OneUp V3, avec un débattement de 210 mm, sur un cadre LG Carbon, je peux voir que je peux m'adapter à cette combinaison de débattement de la tige et de taille de cadre puisque les mesures minimum et maximum possibles sont de 725 mm à 855 mm.

POST MODEL	POST TRAVEL	FRAME SIZE	CARBON					ALLOY				
			XS	SM	MD	LG	XL	XS	SM	MD	LG	XL
		Seat Tube Length	355	365	410	440	470	355	365	410	440	470
		Minimum Insertion	100	100	100	100	100	100	100	100	100	100
		Maximum Insertion	220	230	275	305	335	220	230	275	305	335
<b>X Fusion Manic</b>	125	Minimum saddle height	541	547	592	622	652	541	547	592	622	652
	125	Maximum saddle height	623	633	678	708	738	623	633	678	708	738
	150	Minimum saddle height	605	605	617	647	677	605	605	617	647	677
	150	Maximum saddle height	687	697	742	772	802	687	697	742	772	802
	170	Minimum saddle height	649	649	649	667	697	649	649	649	667	697
	170	Maximum saddle height	701	711	756	786	816	701	711	756	786	816
	190	Minimum saddle height	702	702	702	702	717	702	702	702	702	717
	190	Maximum saddle height	734	744	789	819	849	734	744	789	819	849
<b>2025 Fox Transfer</b>	120	Minimum saddle height	556	566	611	641	671	556	566	611	641	671
	120	Maximum saddle height	646	656	701	731	761	646	656	701	731	761
	150	Minimum saddle height	619	619	642	672	702	619	619	642	672	702
	150	Maximum saddle height	711	721	766	796	826	711	721	766	796	826
	180	Minimum saddle height	684	684	684	701	731	684	684	684	701	731
	180	Maximum saddle height	776	786	831	861	891	776	786	831	861	891
	210	Minimum saddle height	749	749	749	749	761	749	749	749	749	761
	210	Maximum saddle height	841	851	896	926	956	841	851	896	926	956
	240	Minimum saddle height	819	819	819	819	819	819	819	819	819	819
	240	Maximum saddle height	911	921	966	996	1026	911	921	966	996	1026

POST MODEL	POST TRAVEL	FRAME SIZE	CARBON					ALLOY				
			XS	SM	MD	LG	XL	XS	SM	MD	LG	XL
<b>2020-2024 Race Face Turbine R Fox Transfer</b>	125	Minimum saddle height	572	573	618	648	678	572	573	618	648	678
	125	Maximum saddle height	664	674	719	749	779	664	674	719	749	779
	150	Minimum saddle height	626	626	643	673	703	626	626	643	673	703
	150	Maximum saddle height	718	728	773	803	833	718	728	773	803	833
	175	Minimum saddle height	683	683	683	698	728	683	683	683	698	728
	175	Minimum saddle height	775	785	830	860	890	775	785	830	860	890
	200	Minimum saddle height	739	739	739	739	754	739	739	739	739	754
	200	Maximum saddle height	781	791	836	866	896	781	791	836	866	896
<b>OneUp V3 Dropper</b> *Travel can be reduced by up to 20mm, in 10 mm increments.	120	Seat Tube Length	550	560	605	635	665	550	560	605	635	665
	120	Minimum Insertion	650	660	705	735	765	650	660	705	735	765
	150	Maximum Insertion	595	595	635	665	695	595	595	635	665	695
	150	Minimum saddle height	700	710	755	785	815	700	710	755	785	815
	180	Maximum saddle height	660	660	665	695	725	660	660	665	695	725
	180	Minimum saddle height	750	760	805	835	865	750	760	805	835	865
	210	Maximum saddle height	725	725	725	725	755	725	725	725	725	755
	210	Minimum saddle height	800	810	855	885	915	800	810	855	885	915
<b>Reverb AXS</b> *Min post insertion is 80mm, however frame requires 100mm	125	Minimum saddle height	593	600	645	675	705	593	600	645	675	705
	125	Maximum saddle height	710	720	765	795	825	710	720	765	795	825
	150	Minimum saddle height	643	643	670	700	730	643	643	670	700	730
	150	Maximum saddle height	760	770	815	845	875	760	770	815	845	875
	170	Minimum saddle height	683	683	690	720	750	683	683	690	720	750
	170	Maximum saddle height	800	810	855	885	915	800	810	855	885	915

## SPÉCIFICATIONS ET DIMENSIONS

### Réglage de la Portée du Jeu de Direction

Tous les cadres sont équipés de jeux de direction réglables en portée pour affiner la portée. Un jeu de direction de 0 mm / neutre est installé sur le cadre. Dans la boîte de petites pièces ajoutée avec chaque cadre et vélo complet, il y a un jeu supplémentaire de coupelles de jeu de direction de 5 mm qui peuvent être utilisées pour effectuer des ajustements de portée.

Le cadre en carbone Instinct Powerplay SL utilise des coupelles de jeu de direction de style encastré et ovale. Aucun outil n'est nécessaire pour retirer et installer les coupelles dans le cadre. L'alignement des coupelles est automatiquement réalisé grâce à la forme ovale clavetée des coupelles et du tube de direction. Les coupelles comportent un joint torique intégré autour de l'extérieur pour les maintenir fixées dans le cadre et réduire les mouvements susceptibles de provoquer du bruit. Les jeux de direction pour les cadres en carbone sont fabriqués par FSA et sont du modèle No.85-1. Ils utilisent des pièces standard de montage FSA telles que les roulements et les bagues pour garantir que le remplacement des pièces d'usure soit un processus simple.

Le cadre en alliage Instinct Powerplay SL utilise des coupelles de jeu de direction surdimensionnées de style press-fit. Des outils spécialisés pour l'installation des jeux de direction sont nécessaires pour retirer et installer les coupelles dans le cadre. L'alignement des coupelles doit être soigneusement géré pour obtenir un alignement correct en raison de la forme non clavetée des coupelles et du tube de direction. Les coupelles comportent une marque d'alignement sur la face extérieure pour les aligner dans le cadre. Aligner une règle longue le long de cette marque et de la longueur du tube supérieur (coupelle supérieure) ou du tube diagonal (coupelle inférieure) est la manière la plus simple de garantir un alignement correct des coupelles. Les jeux de direction pour les cadres en alliage sont fabriqués par FSA et sont du modèle HS-RM-01. Ils utilisent des pièces standard de montage FSA telles que les roulements et les bagues pour garantir que le remplacement des pièces d'usure soit un processus simple.

### Jeu de direction Instinct Powerplay SL Carbon

QTÉ	PIÈCE	NUMÉRO DE PIÈCE	DESCRIPTION
N/A	Jeu de direction	14100078000013	FSA Part Number   No.85-10mm Offset Headset, complete
N/A	Jeu de direction	1194001	RMB Part Number   No.85-10mm Offset Headset, complete
1	Jeu de direction Cup Set	141-0079000011	FSA Part Number   No.85-15mm Offset cups only
1	Jeu de direction Cup Set	1194002	RMB Part Number   No.85-15mm Offset cups inc. O-rings
1	Joint torique en caoutchouc	160-7042	FSA Top Cap Inner Rubber O-Ring
1	Capuchon	161-4430	FSA 5.3mm Top Cap inc. rubber seal
1	Cuvette de direction avec fente	160-7626	FSA 1 1/8" Headset Compression Ring
1	Roulement	160-6465	FSA Stainless ACB 1 1/8" 36°x45° Bearing
1	Roulement	160-67400E	FSA Stainless ACB 1.5" 36°x45° Bearing
1	Crown Race	160-5536	FSA 1.5" Crown Race

### Jeu de direction Instinct Powerplay SL Alloy

QTÉ	PIÈCE	NUMÉRO DE PIÈCE	DESCRIPTION
N/A	Jeu de direction	1194003	RMB ZS56 66 0mm Offset Headset, complete
N/A	Jeu de direction	1194004	RMB Upper ZS56   5mm Offset Cup Set
1	Joint torique en caoutchouc	160-7042	Top Cap Inner Rubber O-Ring
1	Capuchon	161-4430	FSA 5.3mm Top Cap inc. rubber seal
1	Cuvette de direction avec fente	160-7626	FSA 1 1/8" Headset Compression Ring
1	Roulement	160-6465	FSA Stainless ACB 1 1/8" 36°x45° Bearing
1	Roulement	160-67400E	FSA Stainless ACB 1.5" 36°x45° Bearing
1	Crown Race	160-5536	FSA 1.5" Crown Race

## ŒILLET DE PALIER D'AMORTISSEUR ET QUINCAILLERIE

Votre cadre est équipé de roulements à cartouche dans l'œillet arrière, ce qui permet d'améliorer le comportement sur les petites bosses. Ces roulements sont portés par des coupelles qui s'insèrent très fermement dans l'arbre de l'amortisseur. Si vous faites réviser votre amortisseur, nous vous recommandons vivement de retirer ces composants, car les centres de service de suspension ne peuvent pas garantir leur retour.

La quincaillerie de l'amortisseur avant est un kit standard fourni par le fabricant de l'amortisseur. Le tableau ci-dessous contient des informations techniques sur l'ensemble de la visserie de l'amortisseur, des schémas de référence et des instructions pour le démontage du système d'œillets de roulement.



**Assemblage** Instinct Powerplay SL anneau de roulement de l'amortisseur arrière

**Dimensions** 40 x 8 mm (largeur x diamètre de la quincaillerie)

NUMÉRO D'ARTICLE	QTÉ	OBJET	NUMÉRO DE PIÈCE	DESCRIPTION
N/A	1	KIT ŒILLET DE ROULEMENT	1811007	8 x 40mm Kit d'œillets de palier d'amortisseur
6	2	Palier	1801010	ENDURO 688 LLU MAX 16X8X5
17	2	Coupe de roulement	1800031	ŒILLET DE ROULEMENT POUR 16X8X5 BRG
71	1	Manchon	1807028	ANNEAU DE ROULEMENT MANCHON CENTRAL
18	2	Entretoise de palier	1800032	ENTRETOISE DE ROULEMENT D'ŒILLET, T:6.3, POUR LARGEUR DE MAILLON DE 40 MM

**Assemblage** Instinct Powerplay SL Matériel de Choc Avant

**Dimensions** 25 x 8 mm (largeur de la tige d'amortisseur x diamètre du matériel)

NUMÉRO D'ARTICLE	QTÉ	OBJET	NUMÉRO DE PIÈCE	DESCRIPTION
N/A	1	Kit complet Fox	803-03-328	FOX Mounting Hardware - 9 Piece AL 8mm x 25mm/0.984
N/A	1	Kit complet RockShox	11.4118.091.816	RockShox, Shock Hardware, 8 X 25.0mm

Conseil de pro : Le kit complet Fox est compatible avec les œillets d'amortisseurs Rock Shox. Retirez la bague en téflon de l'œillet Rock Shox avant d'installer le kit Fox.

## ŒILLET À ROULEMENTS POUR AMORTISSEUR ET QUINCAILLERIE

### Retrait des œillets

#### Voici comment retirer le système :

- Utilisez la trousse d'outils pour œillets à roulements de Rocky Mountain (pièce 1810031).
- Insérez la goupille d'un côté de l'œillet.
- Fixez ensuite l'un des outils d'extraction à la cuvette où est insérée la goupille.
- Vissez la vis M8 jusqu'à ce qu'elle soit bien appuyée sur la goupille.
- Fixez l'autre outil d'extraction sur l'autre cuvette.
- Vissez la vis M8 au maximum, jusqu'à ce qu'elle pousse sur la goupille de l'autre côté.
- Continuez à visser jusqu'à ce que l'une des cuvettes soit entièrement extraite.
- Insérez ensuite le poinçon dans l'œillet en l'appuyant solidement sur la cuvette qui est toujours dans l'œillet.
- Avec un marteau, frappez doucement mais fermement sur le poinçon jusqu'à ce que la cuvette soit entièrement extraite de l'œillet.

#### Si vous n'avez pas la trousse d'outils Rocky Mountain, utilisez un extracteur de roulement pour trou borgne :

- Avec l'extracteur (embout de 8 mm), retirez les deux roulements. Insérez la goupille d'un côté de l'œillet.
- Retirez la douille centrale.
- Avec l'extracteur de palier (embout de 10 mm), retirez les cuvettes vides.

*N.B. : Le diamètre intérieur des cuvettes est de 11 mm, et donc trop petit pour l'embout de 12 mm. NE LE FORCEZ PAS. Utilisez plutôt l'embout de 10 mm.*

Installez de nouvelles cuvettes avec une presse à palier ou un étau à mâchoires souples en veillant à appuyer sur le bord extérieur des cuvettes. N'oubliez pas la douille-entretoise entre les cuvettes.

## CONFIGURATION DE LA SUSPENSION

Avant de modifier les réglages de l'amortisseur, il est important de s'informer sur les différents réglages possibles.

### Réglage du ressort

En fonction du modèle d'amortisseur, il se peut que vous deviez ajuster la pression d'air ou la tension du ressort pour obtenir l'affaissement recommandé pour l'Altitude. Consultez le tableau des ressorts ci-dessous pour obtenir des recommandations.

### Rebond

Le réglage du rebond contrôle la vitesse à laquelle la suspension revient en pleine extension après un choc. Si le contrôle du rebond est trop serré, la fourche ou l'amortisseur se déplacera trop lentement et s'enfoncera de plus en plus dans son débattement à chaque coup, ce qui donnera une sensation de raideur. S'il est trop léger, la suspension peut rebondir trop vite et causer une perte de traction et de contrôle.

- Le rebond lent fait référence à une faible vitesse de la fourche ou de l'amortisseur, et non à la vitesse sur le sentier. Cet ajustement affecte le taux de rebond dans la première partie du débattement. Pour chiffrer la chose, on parlera de la plage entre 0 et 40 % du débattement.
- Le rebond rapide fait référence à la vitesse élevée de la fourche ou de l'amortisseur, et non à la vitesse sur le sentier. Cet ajustement affecte le taux de rebond dans la deuxième partie du débattement. Pour chiffrer la chose, on parlera de la plage entre 40 et 100 % du débattement.

## CONFIGURATION DE LA SUSPENSION

### Compression

Le réglage de la compression contrôle la vitesse de déplacement de la suspension dans son débattement lors d'un choc. Si la compression est trop forte, la fourche ou l'amortisseur se déplacera trop lentement et la force de l'impact sera principalement absorbée par le pneu et l'utilisateur. Si elle ne l'est pas assez, la fourche ou l'amortisseur bougera trop vite et la conduite sera pesante et peu réactive.

- La compression lente fait référence à une faible vitesse de la fourche ou de l'amortisseur, et non à la vitesse sur le sentier. Elle résiste aux déplacements de poids de l'utilisateur, aux mouvements de pompage, aux changements de force d'accélération soudains et à d'autres actions lentes. Si elle est trop élevée, la compression lente nuira au confort; si elle ne l'est pas assez, la conduite sera trop souple et peu réactive. La compression lente influence l'ensemble du débattement.

- La compression rapide fait référence à la vitesse élevée de la fourche ou de l'amortisseur, et non à la vitesse sur le sentier. Elle absorbe les gros impacts comme les rochers anguleux et la compression complète. Si elle est trop élevée, la compression rapide nuira au comportement du vélo à grande vitesse sur les sentiers très cahoteux; si elle ne l'est pas assez, l'amortissement ne sera pas suffisant pour les grosses bosses et le débattement risque d'être utilisé au complet.

### Amortisseur hydraulique

L'amortisseur hydraulique fait référence à la résistance à la compression complète que certains amortisseurs peuvent exercer en combinaison avec un dispositif de réglage externe. Cela affecte les derniers 20 % du débattement de l'amortisseur et est utilisé en cas de chocs importants où le vélo risque d'atteindre sa limite d'amortissement.

Veillez consulter les tableaux ci-dessous pour connaître toutes les configurations de l'amortisseur d'origine pour l'Instinct Powerplay SL. En raison du grand nombre d'amortisseurs compatibles avec l'Altitude, nous ne pouvons pas fournir de guides de configuration pour les modèles autres que ceux du fabricant.

### Conseils et astuces en matière de suspension

Lorsque vous ajustez la suspension, prenez note de vos réglages. Pourquoi ne pas utiliser un tableur en ligne sur votre téléphone?

Le retrait de l'amortisseur sur l'Instinct Powerplay SL avec sa suspension peut nécessiter quelques étapes supplémentaires. Voici la marche à suivre. Pour l'installation, suivez les étapes en sens inverse. N'oubliez pas de noter les valeurs de couple données dans la liste des petites pièces, qui se trouve dans le fichier PDF de la vue explosée.

1. Passer au petit pignon de la cassette et bloquer la cage du dérailleur en position ouverte si possible.
2. Retirer la roue.
3. Vérifier que les zones du cadre entre le tube de selle et la biellette sont propres et exemptes de débris.
4. Retirer la vis de l'amortisseur avant.
  - Soutenir le triangle arrière une fois que la quincaillerie de l'amortisseur avant est retirée, et l'étendre doucement vers l'arrière jusqu'à ce que le hauban entre en contact avec le tube de selle.
5. Retirer la vis de l'amortisseur arrière.
  - Si nécessaire, retirer les plaques Ride4 des deux côtés de la biellette.
6. Retirer l'amortisseur
  - Placer une main sous les entretoises des œillets à roulements de chaque côté, car elles tomberont.

## CONFIGURATION DE LA SUSPENSION

### 2025 INSTINCT POWERPLAY SL FOX FLOAT X AIR SHOCK

DIMENSIONS DE L'AMORTISSEUR	SM - MD - LG - XL = 230 X 57.5MM	RÉGLAGE DE L'AMORTISSEUR	0.4 SPACER, CS40, RL40, LMF, REZI B40			
NOTES	AUGMENTER LA PRESSION DE 10PSI   0.7BAR POUR SM *COMPTER LES CLICS À PARTIR DE FERMÉ : 0 CLICS = FERMÉ*					
POIDS DE L'UTILISATEUR	RESSORT EN ACIER	AFFAISSEMENT DE L'AMORTISSEUR	LSR	HBO	LSC	HSC
100lbs   45kg	120psi   8.3bar		10		9 - Open	
110lbs   50kg	130psi   9bar		10		9	
120lbs   55kg	140psi   9.7bar		10 - 9		8 - 9	
130lbs   59kg	150psi   10.3bar		9		8	
140lbs   64kg	160psi   11bar		9 - 8		7 - 8	
150lbs   68kg	170psi   11.7bar		8		7	
160lbs   73kg	180psi   12.4bar	SM - XL 17 - 20mm	8 - 7	Non offert	6 - 7	Non offert
170lbs   77kg	190psi   13.1bar		7		6	
180lbs   82kg	200psi   13.8bar		7 - 6		5 - 6	
190lbs   86kg	210psi   14.5bar		6		5	
200lbs   91kg	220psi   15.2bar		6 - 5		4 - 5	
210lbs   95kg	230psi   15.9bar		5		4	
220lbs   100kg	240psi   16.5bar		5 - 4		3 - 4	
230lbs   105kg	250psi   17.2bar		4		3	
240lbs   109kg	260psi   17.9bar		4 - 3		2 - 3	
250lbs   114kg	270psi   18.6bar		3		2	

### 2025 INSTINCT POWERPLAY SL FOX FLOAT AIR SHOCK

DIMENSIONS DE L'AMORTISSEUR	XS = 210 X 52.5MM	RÉGLAGE DE L'AMORTISSEUR	0.2 SPACER, CL, RM, CMF			
NOTES	AUGMENTER LA PRESSION DE 10PSI   0.7BAR POUR SM *COMPTER LES CLICS À PARTIR DE FERMÉ : 0 CLICS = FERMÉ*					
POIDS DE L'UTILISATEUR	RESSORT EN ACIER	AFFAISSEMENT DE L'AMORTISSEUR	LSR	HBO	LSC	HSC
100lbs   45kg	120psi   8.3bar		10			
110lbs   50kg	130psi   9bar		10			
120lbs   55kg	140psi   9.7bar		10 - 9			
130lbs   59kg	150psi   10.3bar		9			
140lbs   64kg	160psi   11bar		9 - 8			
150lbs   68kg	170psi   11.7bar		8			
160lbs   73kg	180psi   12.4bar	XS 15 - 18mm	8 - 7			
170lbs   77kg	190psi   13.1bar		7	Non offert	Start Open Adjust to preference	Non offert
180lbs   82kg	200psi   13.8bar		7 - 6			
190lbs   86kg	210psi   14.5bar		6			
200lbs   91kg	220psi   15.2bar		6 - 5			
210lbs   95kg	230psi   15.9bar		5			
220lbs   100kg	240psi   16.5bar		5 - 4			
230lbs   105kg	250psi   17.2bar		4			
240lbs   109kg	260psi   17.9bar		4 - 3			
250lbs   114kg	270psi   18.6bar		3			

## CONFIGURATION DE LA SUSPENSION

### 2025 INSTINCT POWERPLAY SL ROCKSHOX SUPER DELUXE AIR SHOCK

DIMENSIONS DE L'AMORTISSEUR	SM - MD - LG - XL = 230 X 57.5MM   BC EDITION = 230 X 60MM	RÉGLAGE DE L'AMORTISSEUR	MD - LG - XL = 0 NEG 1 POS TOKEN - REBOUND 25 - COMP 30 - LOCKOUT 4 SM = 0 NEG 0 POS TOKENS - REBOUND 25 - COMP 26 - LOCKOUT 4			
NOTES	AUGMENTER LA PRESSION DE 10PSI   0,7BAR POUR SM *COMPTER LES CLICS À PARTIR DE FERMÉ : 0 CLICS = FERMÉ*					
POIDS DE L'UTILISATEUR	RESSORT EN ACIER	AFFAISSEMENT DE L'AMORTISSEUR	LSR	HBO	LSC	HSC
100lbs   45kg	120psi   8.3bar		11 - 12			
110lbs   50kg	130psi   9bar		10 - 11			
120lbs   55kg	140psi   9.7bar		9 - 11			
130lbs   59kg	150psi   10.3bar		8 - 9			
140lbs   64kg	160psi   11bar		8 - 10			
150lbs   68kg	170psi   11.7bar	SM - XL	6 - 7	L'option Hydraulic Bottom Out intervient pour limiter le flux d'huile dans les derniers 20% de la course, offrant un coussin hydraulique doux qui réduit la dureté du bas de caisse.	Commencez au point mort (3ème position) Ajustez d'un clic à la fois pour obtenir le soutien souhaité sur les mouvements à faible vitesse de l'arbre, tels que le pompage à travers le rouleau, la précharge pour un saut ou une chute, ou plus de soutien lors de l'escalade.	Commencez par le réglage neutre (3e position). Ajustez d'un clic à la fois pour obtenir le soutien désiré sur les mouvements à grande vitesse de l'arbre, tels que les coups de carre, les terrains rocailleux et les grosses chutes..
160lbs   73kg	180psi   12.4bar	17 - 20mm	6 - 7			
170lbs   77kg	190psi   13.1bar	BC Edition	5 - 6			
180lbs   82kg	200psi   13.8bar	18 - 21mm	5 - 6			
190lbs   86kg	210psi   14.5bar		4 - 5			
200lbs   91kg	220psi   15.2bar		4 - 5			
210lbs   95kg	230psi   15.9bar		3 - 4			
220lbs   100kg	240psi   16.5bar		2 - 3			
230lbs   105kg	250psi   17.2bar		2 - 3			
240lbs   109kg	260psi   17.9bar		1 - 2			
250lbs   114kg	270psi   18.6bar		1 - 2			

### 2025 INSTINCT POWERPLAY SL ROCKSHOX DELUXE AIR SHOCK

DIMENSIONS DE L'AMORTISSEUR	XS = 210 X 52.5MM   BC EDITION = 210 X 55MM	RÉGLAGE DE L'AMORTISSEUR	MD - LG - XL = 0 NEG 1 POS TOKENS, PROGRESSIVE REB-LOW COMP TUNE, 320LB LOCKOUT SM = 0 NEG 0 POS TOKENS, PROGRESSIVE REB-L1 COMP TUNE, 320LB LOCKOUT XS = 0 NEG 0 POS TOKENS, PROGRESSIVE REB-LOW COMP TUNE, 320LB THRESHOLD			
NOTES	AUGMENTER LA PRESSION DE 10PSI   0,7BAR POUR SM *COMPTER LES CLICS À PARTIR DE FERMÉ : 0 CLICS = FERMÉ*					
POIDS DE L'UTILISATEUR	RESSORT EN ACIER	AFFAISSEMENT DE L'AMORTISSEUR	LSR	HBO	LSC	HSC
100lbs   45kg	120psi   8.3bar		10			
110lbs   50kg	130psi   9bar		10			
120lbs   55kg	140psi   9.7bar		10 - 9			
130lbs   59kg	150psi   10.3bar		9			
140lbs   64kg	160psi   11bar		9 - 8			
150lbs   68kg	170psi   11.7bar	XS	8			
160lbs   73kg	180psi   12.4bar	15 - 18mm	8 - 7			
170lbs   77kg	190psi   13.1bar	BC Edition	7	Non offert	Start Open Adjust to preference	Non offert
180lbs   82kg	200psi   13.8bar	16 - 19mm	7 - 6			
190lbs   86kg	210psi   14.5bar		6			
200lbs   91kg	220psi   15.2bar		6 - 5			
210lbs   95kg	230psi   15.9bar		5			
220lbs   100kg	240psi   16.5bar		5 - 4			
230lbs   105kg	250psi   17.2bar		4			
240lbs   109kg	260psi   17.9bar		4 - 3			
250lbs   114kg	270psi   18.6bar		3			

## DIMENSIONS CRITIQUES

ITEM NUMBER	CATEGORY	ITEM	DIMENSION	PART NUMBER	DESCRIPTION
1	Headset	Carbon Frame Headset	FSA No.85-1 0mm Offset		FSA No.85-1 0mm Offset Headset, complete. See Headset chart for information
		Carbon Frame Headset Cup Set	FSA No.85-1 5mm Offset		FSA No.85-1 5mm Offset cups only. See Headset chart for information
		Alloy Frame Headset	FSA ZS56 66 0mm Offset		FSA RMB ZS56 66 0mm Offset Headset, complete. See Headset chart for information
		Alloy Frame Headset Cup Set	FSA ZS56 66 5mm Offset		FSA RMB ZS56 66 5mm Offset cups only. See Headset chart for information
2	Fork	Fork Travel	150mm		Compatible with 160mm
		Fork Offset	27.5"   XS = 37mm		
		Maximum Axle to Crown Height	29"   SM - MD - LG - XL = 42 - 44mm		
			27.5"   XS = 557.6mm		
3	Shock	Shock Size	XS = 210 x 52.5mm		XS frames are compatible with 210 x 55mm shocks. This increases rear wheel travel to 150mm.
			SM - MD - LG - XL = 230 x 57.5mm		SM - MD - LG - XL frames are compatible with 230 x 60mm shocks. This increases rear wheel travel to 150mm.
		Shock Tune	See Description		Refer to Shock Setup chart for tune information
		Forward Shock Hardware	25 x 8mm		See Shock Hardware chart for information
		Rear Shock Hardware	40 x 8mm	1811007	Requires custom bearing eyelet hardware. See Shock Hardware chart for information
		Approved Shock Fitment	See Description		All Fox rear shock models. All RockShox rear shock models. All Cane Creek Shock models. Other rear shock manufacturers' models may fit, but will require fitment on frame to check clearances at full extension and compression.
4	Seatpost	Seat Tube Inner Diameter	30.9mm		
		Seat Tube Outer Diameter	34.9mm		
		Seat Tube Minimum Insertion	100mm		
		Seat Tube Machined Ream Depth (Identical on Carbon & Alloy)	XS = 220mm		
			SM = 230mm		
			MD = 275mm		For seatpost fitment information, refer to the seatpost fitment section in this manual
LG = 305mm					
	XL = 335mm				

## DIMENSIONS CRITIQUES

ITEM NUMBER	CATEGORY	ITEM	DIMENSION	PART NUMBER	DESCRIPTION
		Chainring Size Range	34T		Instinct Powerplay SL bikes are only compatible with 34 tooth chainrings.
		OEM Chainring Size   Chain Length	27.5"   XS = 34T   122L 29"   SM - MD = 34T   122L 29"   LG - XL = 34T   124L		
5	Crankset	Lower Chain Guide Kit	See Description	1995026	Bashguard bracket with idler, 2025 Instinct Powerplay SL
		Chain Guide	See Description	1995013	Motor Output Chainguide, 2025 Instinct Powerplay SL
		Bashguard	2-Bolt Custom Mount		2-Bolt mounting pattern to fit Instinct Powerplay SL bashguards only
		Bottom Bracket	PressFit BB92		Remove the bottom bracket's inner plastic sleeve to install.
		Chainline	51mm		Compatible Rocky Mountain Ratchet Spider assembly only.
7	Brake	Maximum Rotor Diameter	223mm		
		Maximum Rotor Thickness	2.0mm		
8	Wheel	Wheel Size	XS = 27.5" SM - MD - LG - XL = 29"		XS is only compatible with 27.5" wheels. MX compatible on all sizes with dedicated link (Link C   1815087)
		Maximum Tire Width	2.5"   63mm		
		Hub Spacing	12 x 148mm		
9	Rear Hub	Rear Axle	12 x 1.0 x 173mm	3222000	Diameter 12mm x Thread Pitch 1.0mm x Length 173mm
		Complete Hanger Kit	See Description	1812002	Includes Hanger, nut, and washer. For individual parts see exploded diagram
		UDH   Transmission	See Description		Frame is UDH and Eagle Transmission compatible.

## DIRECTIVES DE SERRAGE DES FIXATIONS

Le couple de serrage correct des fixations filetées est très important pour votre sécurité. Serrez toujours les fixations au couple correct. En cas de conflit entre les instructions de ce manuel et les informations fournies par un fabricant de composants, consultez votre revendeur ou le représentant du service clientèle du fabricant pour obtenir des éclaircissements. Les boulons trop serrés peuvent s'étirer et se déformer. Les boulons trop lâches peuvent bouger et se fatiguer. L'une ou l'autre de ces erreurs peut entraîner une défaillance soudaine du boulon.

Utilisez toujours une clé dynamométrique correctement calibrée pour serrer les fixations critiques de votre vélo. Suivez attentivement les instructions du fabricant de la clé dynamométrique sur la manière correcte de régler et d'utiliser la clé pour obtenir des résultats précis.

### VUE EXPLOSÉE

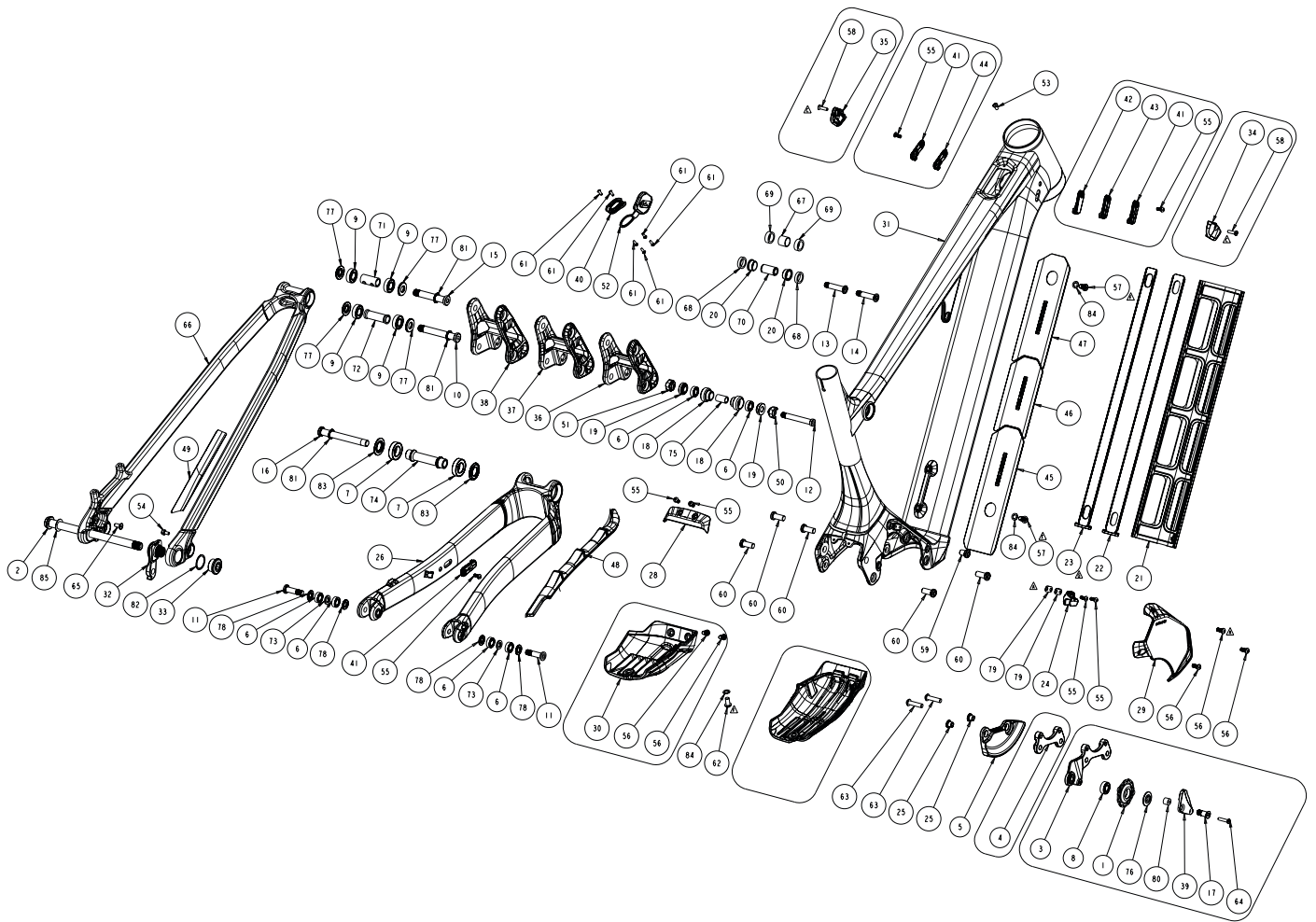

## LISTE DES KITS DE PETITES PIÈCES

<b>2025 INSTINCT POWERPLAY SL CARBON ALLOY</b>							
# LIST	P1	QTY	ITEM	PART NO.	SUPPLIER	REVISION	DESCRIPTION
37	1	LINK		<b>1815085</b> 1095002	<b>ZCA013</b>		<b>2025 INSTINCT PP LINK 29"</b> MY25 INSTINCT POWERPLAY - LINK B
36	1	LINK		<b>1815086</b> 1095001	<b>ZCA013</b>		<b>2025 INSTINCT PP LINK 27.5"</b> MY25 INSTINCT POWERPLAY - LINK A
38	1	LINK		<b>1815087</b> 1095003	<b>ZCA013</b>		<b>2025 INSTINCT PP MULLET LINK</b> MY25 INSTINCT POWERPLAY - LINK C
32	1	HANGER		<b>1812002</b> 1092003	<b>PTW047</b>		<b>2022 HANGER KIT 12 x1.0</b> MY22 REAR DER. HANGER, M12X1, UDH COMPATIBLE
33	1	HANGER NUT		1801008	PTW047		RMB UDH HANGER NUT, 7075_T6, HARD BLACK ANODIZED
82	1	WASHER		1801009	PTW047		WASHER, 20X24X0.5MM, 304 SS
16	1	BOLT		<b>1815088</b> 1805154	<b>PTW047</b>		<b>2025 INSTINCT PP PIVOT BOLT KIT</b> BOLT, MAIN PIVOT, 10 MM OD, M10x1.25, 86 MM L, 6 MM HEX
10	1	BOLT		1801004	PTW047		LINK BOLT, LOWER, M10X1.0, L:70.5, 6MM HEX
15	1	BOLT		1804058	PTW047		UPPER LINK BOLT, M10x1.0, L:59.4
11	2	BOLT		1801007	PTW047		ALTITUDE DROPOUT BOLT, M8X1.0, L:30, 6MM HEX
71	1	SLEEVE		1800008	PTW047		TT BEARING SLEEVE, ID:10, OD:14, L:29
72	1	SLEEVE		1800010	PTW047		SS BEARING SLEEVE, ID:10, OD:14, L:41, NECKED
74	1	SLEEVE		1805156	PTW047		SLEEVE, MAIN PIVOT, 10MM ID, 52.5 MM L
73	2	SLEEVE		1800040	PTW047		DROPOUT BEARING SLEEVE, OD:14, ID:8, T:1.8, 6061 ALU
77	4	SPACER		1800009	PTW047		LINK BEARING SPACER, OD:22, ID:10, T:2.5
78	4	SPACER		1800039	PTW047		DO BEARING SPACER, OD:16, ID:8, T:1.75, 6061 ALU
81	3	WASHER		1800019	PTW047		WASHERID: 10.2, OD: 15.5, T:1
83	2	WASHER		1805155	PTW047		WASHER, MAIN PIVOT, 15MM ID, 27.5MM OD, 2.5MM T
11	2	BOLT		<b>1814055</b> 1801007	<b>PTW047</b>		<b>DROPOUT PIVOT BOLT KIT</b> ALTITUDE DROPOUT BOLT, M8X1.0, L:30, 6MM HEX
6	6	BEARING		<b>1815089</b> 1801010	<b>ZCA013</b>		<b>2025 INSTINCT PP PIVOT BEARING KIT</b> ENDURO 688 LLU MAX 16X8X5
9	4	BEARING		1807042			ENDURO 6900 2RS MAX 22X10X6
7	2	BEARING		1805159			ENDURO 6902 LLU MAX 28X15X7
12	1	BOLT		<b>1815090</b> 1802008	<b>PTW047</b>		<b>2025 INST PP AL SHOCK BOLT KIT</b> RIDE 4 BOLT, M8 x 1, OD: 8 mm, L:56, 5 mm Hex
14	1	BOLT		1804057			SHOCK BOLT, M8X1.0, L:35, 5mm HEX
12	1	BOLT		<b>1815091</b> 1802008	<b>PTW047</b>		<b>2025 INST PP CR SHOCK BOLT KIT</b> RIDE 4 BOLT, M8 x 1, OD: 8 mm, L:56, 5 mm Hex
13	1	BOLT		1803026			SHOCK BOLT, M8X1.0, L:36.5, 5mm hex
6	2	BEARING		<b>1811007</b> 1801010	<b>ZCA013</b>		<b>SHOCK BEARING EYELET KIT 2021</b> ENDURO 688 LLU MAX 16X8X5
75	1	SLEEVE		1807028	PTW047		BEARING EYELET CENTRE SLEEVE
18	2	BRG CUP		1800031	PTW048		BEARING EYELET FOR 16X8X5 BRG
19	2	BRG SPACER		1800032	PTW049		EYELET BEARING SPACER, T:6.3, FOR 40 MM LINK WIDTH
2	1	AXLE, REAR		<b>1812007</b> 3222000	<b>PTW047</b>		<b>AXLE KIT BOOST 12X1.0</b> REAR AXLE 12X1.0 L:173MM, HARD BLACK ANODIZE
85	1	WASHER		3227006	PTW047		WASHER, 12x19x0.5MM, 304 SS
34	1	HT PORT COVER		<b>1815092</b> 1803012	<b>PTW047</b>		<b>**** 2025 INST PP HT PANEL KIT (NEW)</b> 2023 SLAYER CARBON HT PORT COVER, RIGHT
35	1	HT PORT COVER		1803013	PTW047		2023 SLAYER CARBON HT PORT COVER, LEFT
58	2	SCREW		1805077-BK	PTW048		C'SUNK SOCKET SCREW, M4X16, STAINLESS STEEL, BLACK

## LISTE DES KITS DE PETITES PIÈCES

		<b>1815093</b>	<b>ZCA013</b>	<b>POWERPLAY ALLOY FRAME HT CABLE PORT KIT</b>
55	3 SCREW	1804060		M4X0.7, 10MM, 2.5 HEX, BUTTON HEAD, SS, BLACK
41	3 PORT COVER	1093011		ALLOY CABLE PORT COVER DOUBLE HOLE
42	1 PORT COVER	1093012		ALLOY CABLE PORT COVER BLANK
43	1 PORT COVER	1093013		ALLOY CABLE PORT COVER SINGLE 4mm HOLE
44	1 PORT COVER	1093014		ALLOY CABLE PORT COVER SINGLE 5mm HOLE
		<b>1815094</b>		<b>ALLOY POWERPLAY FRAME CS CABLE PORT KIT STD SIZE</b>
41	1 PORT COVER	1093011		ALLOY CABLE PORT COVER DOUBLE HOLE
55	1 SCREW	1804060		M4X0.7, 10MM, 2.5 HEX, BUTTON HEAD, SS, BLACK
		<b>1812010</b>	<b>PTW047</b>	<b>RIDE 4 THREADED CHIP KIT</b>
50	1 RIDE 4 CHIP	1802009	PTW047	RIDE 4 CHIP, NO THREAD.
51	1 RIDE 4 CHIP	1802010	PTW047	RIDE 4 CHIP, THREADED, M8 x 1.
		<b>1815095</b>	<b>ZCA013</b>	<b>2025 INSTINCT PP PROTECTION KIT XS/SM</b>
48	1 PROTECTOR	1705006		2025 INSTINCT POWERPLAY CHAINSTAY PROTECTOR
49	1 PROTECTOR	3702021		SEATSTAY PROTECTOR, TRIMMED
45	1 PROTECTOR	1705003		DOWNTUBE PROTECTOR - A - 2025 INSTINCT POWERPLAY
46	2 PROTECTOR	1705004		DOWNTUBE PROTECTOR - B - 2025 INSTINCT POWERPLAY
		<b>1815096</b>	<b>ZCA013</b>	<b>2025 INSTINCT PP PROTECTION KIT MD/LG/XL</b>
48	1 PROTECTOR	1705006		2025 INSTINCT POWERPLAY CHAINSTAY PROTECTOR
49	1 PROTECTOR	3702021		SEATSTAY PROTECTOR, TRIMMED
45	1 PROTECTOR	1705003		DOWNTUBE PROTECTOR - A - 2025 INSTINCT POWERPLAY
46	1 PROTECTOR	1705004		DOWNTUBE PROTECTOR - B - 2025 INSTINCT POWERPLAY
47	1 PROTECTOR	1705005		DOWNTUBE PROTECTOR - C - 2025 INSTINCT POWERPLAY
		<b>1815097</b>		<b>2025 INSTINCT PP BB COVER SM/MD/LG/XL</b>
27	1 COVER	1995005		BOTTOM BRACKET COVER, CO-MOLDED, 2025 IPP
62	1 SCREW	1805170		SCREW, BUTTON HEAD, 18-8 SS, RAW STAINLESS, M6X1.0, 12MM LENGTH
84	1 WASHER	1805172		WASHER, 6x10x0.5MM, 304 SS
		<b>1815098</b>		<b>2025 INSTINCT PP BB COVER XS</b>
30	1 COVER	1995018		FOR X-SMALL ONLY, BOTTOM BRACKET COVER, 2025 INSTINCT POWERPLAY
62	1 SCREW	1805170		SCREW, BUTTON HEAD, 18-8 SS, RAW STAINLESS, M6X1.0, 12MM LENGTH
84	1 WASHER	1805172		WASHER, 6x10x0.5MM, 304 SS
56	2 SCREW	1804063		LOW PROFILE SOCKET HEAD SCREW, M5X10, STAINLESS STEEL, BLACK
		<b>1815099</b>		<b>2025 INSTINCT PP MAIN PIVOT COVER</b>
28	1 COVER	1995016		MAIN PIVOT COVER, 2025 INSTINCT POWERPLAY
55	2 SCREW	1804060		M4X0.7, 10MM, 2.5 HEX, BUTTON HEAD, SS, BLACK
		<b>1815100</b>	<b>PTW047</b>	<b>UDH STOP SCREW KIT M4X8</b>
54	1 SCREW	1802012		UDH STOP SCREW M4X8
		<b>1814050</b>	<b>ZCA013</b>	<b>5M OFFSET HEAD SET CUPS KIT CR BIKES</b>
1	HEAD SET CUP	1194002	PUS105	FSA 5MM OFFSET OVAL CUPS W/ORING CR BIKES
		<b>1814051</b>	<b>ZCA013</b>	<b>5M OFFSET HEAD SET CUPS KIT AL BIKES</b>
1	HEAD SET CUP	1194004	PUS105	FSA 5MM OFFSET CUPS AL BIKES
		<b>1814052</b>	<b>ZCA013</b>	<b>OVAL OFFSET HEADSET KIT CR BIKES</b>
1	HEADSET	1194001	PUS105	FSA NO.85 1.5" OMM OFFSET OVAL CUPS STAINLESS
		<b>1814053</b>	<b>ZCA013</b>	<b>OFFSET HEADSET KIT AL BIKES</b>
1	HEADSET	1194003	PUS105	FSA ZS56   66 OMM OFFSET HS STAINLESS STEEL
		<b>1815101</b>		<b>2025 INSTINCT PP BASH GUARD KIT</b>
5	1 BASH GUARD PLATE	1995028		BASH GUARD PLATE - 2025 INSTINCT POWERPLAY
25	2 CHAINRING BOLT	1805173		CHAINRING BOLT, CUSTOM, M8 X 0.75, LENGTH 6MM

## LISTE DES KITS DE PETITES PIÈCES

		<b>1815102</b>		<b>2025 INSTINCT PP CHAIN GUIDE KIT W/BASH GUARD</b>
5	1 BASH GUARD PLATE	1995028		BASH GUARD PLATE - 2025 INSTINCT POWERPLAY
4	1 BASH GUARD BRACKET	1995027		BASH GUARD BRACKET, WITHOUT IDLER - 2025 INSTINCT POWERPLAY
63	2 SCREW	1805171		SCREW, BUTTON HEAD, 18-8 SS, BLACK, M6X1.0, 25MM LENGTH
25	2 CHAINRING BOLT	1805173		CHAINRING BOLT, CUSTOM, M8 X 0.75, LENGTH 6MM
		<b>1815103</b>		<b>2025 INSTINCT PP CHAIN GUIDE KIT W/ BASH GUARD &amp; IDLER</b>
3	1 BASH GUARD BRACKET	1995026		BASH GUARD BRACKET, WITH IDLER - 2025 INSTINCT POWERPLAY
17	1 BOLT, M8X18	1807126		BOLT M8 X 18MM CUSTOM. 6061 HARD BLACK ANO.
39	1 PLATE	1094020		REAPER POWERPLAY LOWER PULLEY PLATE
64	1 SCREW, M4X20	1809011		C'SUNK SOCKET SCREW, M4x20mm, STAINLESS STEEL 316
80	1 SPACER	3399006		LOWER CHAIN GUIDE SPACER
1	1 11T COG	1347012	REV B	11T COG, FOR 19mm BEARING
8	1 BEARING	1807036		ENDURO 698 LLU 19X8X6
76	1 SPACER	1347013		CHAINSTAY PULLEY GUIDE SPACER,
5	1 BASH GUARD PLATE	1995028		BASH GUARD PLATE - 2025 INSTINCT POWERPLAY
63	2 SCREW	1805171		SCREW, BUTTON HEAD, 18-8 SS, BLACK, M6X1.0, 25MM LENGTH
25	2 CHAINRING BOLT	1805173		CHAINRING BOLT, CUSTOM, M8 X 0.75, LENGTH 6MM
		<b>1998024</b>		<b>CHAIN STAY PULLEY KIT</b>
1	1 11T COG	1347012	REV B	11T COG, FOR 19mm BEARING
8	1 BEARING	1807036		ENDURO 698 LLU 19X8X6
76	1 SPACER	1347013		CHAINSTAY PULLEY GUIDE SPACER,
		<b>1815104</b>	<b>PTW047</b>	<b>2025 INSTINCT POWERPLAY SL UPPER CHAIN GUIDE KIT</b>
24	1 CHAIN GUIDE	1995013		MOTOR OUTPUT CHAIN GUIDE, 2025 INSTINCT POWERPLAY
55	2 SCREW	1804060		M4X0.7, 10MM, 2.5 HEX, BUTTON HEAD, SS, BLACK
79	2 SPACER	1805191		CHAINGUIDE SPACER, 0.5MM, 304 STAINLESS STEEL, 2025 IPP
		<b>1815105</b>	<b>PTW047</b>	<b>2025 INSTINCT POPWERPLAY BATTERY BOLT KIT</b>
57	2 SCREW	1804065		M6 X 14MM, LOW BUTTON HEAD SCREW, SS, BLACK COATED
84	1 WASHER	1805172		WASHER, 6x10x0.5MM, 304 SS
		<b>1815106</b>	<b>PTW047</b>	<b>2025 INSTINCT POWERPLAY CHARGE PORT KIT</b>
40	1 PLATE	1995015		CHARGE PORT PLATE, 2025 INSTINCT POWERPLAY
52	1 RUBBER CAP	1995014		CHARGE PORT RUBBER CAP, 2025 INSTINCT POWERPLAY
61	6 SCREW	1805160		SCREW, BUTTON HEAD, 18-8 SS, BLACK, M3X0.5, L:8MM
		<b>1815107</b>	<b>PTW047</b>	<b>2025 INSTINCT PP SL ALLOY CABLE FLUTE XS/SM</b>
21	1 CABLE GUIDE	1995006		DOWNTUBE CABLE GUIDE FLUTE - 2025 INSTINCT POWERPLAY
22	1 CABLE GUIDE	1995007		DOWNTUBE CABLE GUIDE WEDGE - 2025 INSTINCT POWERPLAY
		<b>1815114</b>	<b>PTW047</b>	<b>2025 INSTINCT PP SL ALLOY CABLE FLUTE MD/LG/XL</b>
21	1 CABLE GUIDE	1995006		DOWNTUBE CABLE GUIDE FLUTE - 2025 INSTINCT POWERPLAY
23	1 CABLE GUIDE	1995048		DOWNTUBE CABLE GUIDE WEDGE - SLIM - 2025 IPP
		<b>1815108</b>	<b>PTW047</b>	<b>2025 INSTINCT POWERPLAY SL DRIVE SIDE MOTOR COVER</b>
29	1 COVER	1995017		DS COVER, 2025 INSTINCT POWERPLAY
56	3 SCREW	1804063		LOW PROFILE SOCKET HEAD SCREW, M5X10, STAINLESS STEEL, BLACK
		<b>1815109</b>	<b>PTW047</b>	<b>2025 INSTINCT POWERPLAY SL MOTOR MOUNT BOLT KIT</b>
60	5 SCREW	1805158		MOTOR MOUNTING SCREW, M8x1.25, 18 MM L, 304 SS, BUTTON HEAD
59	1 SCREW	1805157		MOTOR MOUNTING SCREW, M8x1.25, 10 MM L, 304 SS, BUTTON HEAD

## LISTE DES PIÈCES ET INSTRUCTIONS D'ASSEMBLAGE

#	QTY ITEM	PART NO.	DESCRIPTION	SUPPLIER	TORQUE(Nm)	INSTALLATION NOTES
1	1	11T COG	1347012 11T COG, FOR 19mm BEARING	OVERTOP		
2	1	AXLE, REAR	3222000 REAR AXLE 12X1.0 L:173MM, HARD BLACK ANODIZE	OVERTOP		10 Grease axle shaft and threads
3	1	BASH GUARD BRACKET	1995026 BASH GUARD BRACKET, WITH IDLER - 2025 INSTINCT POWERPLAY	SHING FONG		
4	1	BASH GUARD BRACKET	1995027 BASH GUARD BRACKET, WITHOUT IDLER - 2025 INSTINCT POWERPLAY	SHING FONG		
5	1	BASH GUARD PLATE	1995028 BASH GUARD PLATE - 2025 INSTINCT POWERPLAY	CREATE THINK		
6	6	BEARING	1801010 ENDURO 688 LLU MAX 16X8X5	ABI		Grease bearing race faces before installation
7	2	BEARING	1805159 ENDURO 6902 LLU MAX 28X15X7	ABI		Grease bearing race faces before installation
8	1	BEARING	1807036 ENDURO 698 LLU 19X8X6	ABI		Grease bearing race faces before installation
9	4	BEARING	1807042 ENDURO 6900 2RS MAX 22X10X6	ABI		Grease bearing race faces before installation
10	1	BOLT	1801004 LINK BOLT, LOWER, M10X1.0, L:70.5, 6MM HEX	OVERTOP		10 Grease axle shaft, Loctite 243 (blue) on threads
11	2	BOLT	1801007 ALTITUDE DROPOUT BOLT, M8X1.0, L:30, 6MM HEX	OVERTOP		10 Grease axle shaft, Loctite 243 (blue) on threads
12	1	BOLT	1802008 RIDE 4 BOLT, M8 x 1, OD: 8 mm, L:56, 5 mm Hex	OVERTOP		10 Grease axle shaft, Loctite 243 (blue) on threads
13	1	BOLT	1803026 SHOCK BOLT, M8X1.0, L:36.5, 5mm hex	OVERTOP		10 Grease axle shaft, Loctite 243 (blue) on threads
14	1	BOLT	1804057 SHOCK BOLT, M8X1.0, L:35, 5mm HEX	OVERTOP		10 Grease axle shaft, Loctite 243 (blue) on threads
15	1	BOLT	1804058 UPPER LINK BOLT, M10x1.0, L:59.4	OVERTOP		10 Grease axle shaft, Loctite 243 (blue) on threads
16	1	BOLT	1805154 BOLT, MAIN PIVOT, 10 MM OD, M10x1.25, 86 MM L, 6 MM HEX	OVERTOP		14 Grease axle shaft, Loctite 243 (blue) on threads
17	1	BOLT, M8X18	1807126 BOLT M8 X 18MM CUSTOM. 6061 HARD BLACK ANO.	OVERTOP		8 Grease axle shaft, Loctite 243 (blue) on threads
18	2	BRG CUP	1800031 BEARING EYELET FOR 16X8X5 BRG	OVERTOP		
19	2	BRG SPACER	1800032 EYELET BEARING SPACER, T:6.3, FOR 40 MM LINK WIDTH	OVERTOP		
20	2	BUSHING, FOX	N/A FOX_IGUS_BUSHING			
21	1	CABLE GUIDE	1995006 DOWNTUBE CABLE GUIDE FLUTE - 2025 INSTINCT POWERPLAY	CREATE THINK		
22	1	CABLE GUIDE	1995007 DOWNTUBE CABLE GUIDE WEDGE - 2025 INSTINCT POWERPLAY	CREATE THINK		
23	1	CABLE GUIDE	1995048 DOWNTUBE CABLE GUIDE WEDGE - SLIM - 2025 IPP	CREATE THINK		USE ONLY FOR ALLOY FT SIZE X-SMALL & SMALL
24	1	CHAIN GUIDE	1995013 MOTOR OUTPUT CHAIN GUIDE, 2025 INSTINCT POWERPLAY	CREATE THINK		
25	2	CHAINRING BOLT	1805173 CHAINRING BOLT, CUSTOM, M8 X 0.75, LENGTH 6MM	OVERTOP		
26	1	CHAINSTAYS	SEE TABLE CHAINSTAYS - MY25 INSTINCT POWERPLAY	MK (RANBOW)		
27	1	COVER	1995005 BOTTOM BRACKET COVER, CO-MOLDED, 2025 IPP	CREATE THINK		
28	1	COVER	1995016 MAIN PIVOT COVER, 2025 INSTINCT POWERPLAY	CREATE THINK		
29	1	COVER	1995017 DS COVER, 2025 INSTINCT POWERPLAY	CREATE THINK		
30	1	COVER	1995018 FOR X-SMALL ONLY, BOTTOM BRACKET COVER, 2025 INSTINCT POWERPLAY	CREATE THINK		
31	1	FRONT TRIANGLE	SEE TABLE FRONT TRIANGLE - MY25 INSTINCT POWERPLAY	MK (RANBOW)		
32	1	HANGER	1092003 MY22 REAR DER. HANGER, M12X1, UDH COMPATIBLE	OVERTOP		
33	1	HANGER NUT	1801008 RMB UDH HANGER NUT, 7075_T6, HARD BLACK ANODIZED	OVERTOP		20 Apply loctite 243 (Blue) on hanger's external threads only
34	1	HT PORT COVER	1803012 2023 SLAYER CARBON HT PORT COVER, RIGHT	OVERTOP		
35	1	HT PORT COVER	1803013 2023 SLAYER CARBON HT PORT COVER, LEFT	OVERTOP		
36	1	LINK	1095001 MY25 INSTINCT POWERPLAY - LINK A	MK (RANBOW)		
37	1	LINK	1095002 MY25 INSTINCT POWERPLAY - LINK B	MK (RANBOW)		
38	1	LINK	1095003 MY25 INSTINCT POWERPLAY - LINK C	MK (RANBOW)		DO NOT ORDER, DO NOT INCLUDE
39	1	PLATE	1094020 REAPER POWERPLAY LOWER PULLEY PLATE	OVERTOP		
40	1	PLATE	1995015 CHARGE PORT PLATE, 2025 INSTINCT POWERPLAY	CREATE THINK		
41	3	PORT COVER	1093011 ALLOY CABLE PORT COVER DOUBLE HOLE	CREATE THINK		
42	1	PORT COVER	1093012 ALLOY CABLE PORT COVER BLANK	CREATE THINK		
43	1	PORT COVER	1093013 ALLOY CABLE PORT COVER SINGLE 4mm HOLE	CREATE THINK		
44	1	PORT COVER	1093014 ALLOY CABLE PORT COVER SINGLE 5mm HOLE	CREATE THINK		
45	1	PROTECTOR	1705003 DOWNTUBE PROTECTOR - A - 2025 INSTINCT POWERPLAY	CREATE THINK		
46	1	PROTECTOR	1705004 DOWNTUBE PROTECTOR - B - 2025 INSTINCT POWERPLAY	CREATE THINK		
47	1	PROTECTOR	1705005 DOWNTUBE PROTECTOR - C - 2025 INSTINCT POWERPLAY	CREATE THINK		
48	1	PROTECTOR	1705006 2025 INSTINCT POWERPLAY CHAINSTAY PROTECTOR	CREATE THINK		
49	1	PROTECTOR	3702021 SEATSTAY PROTECTOR, TRIMMED	VELO		
50	1	RIDE 4 CHIP	1802009 RIDE 4 CHIP, NO THREAD.	OVERTOP		
51	1	RIDE 4 CHIP	1802010 RIDE 4 CHIP, THREADED, M8 x 1.	OVERTOP		
52	1	RUBBER CAP	1995014 CHARGE PORT RUBBER CAP, 2025 INSTINCT POWERPLAY	CREATE THINK		
53	1	SCREW	1800024-BK C'SUNK SOCKET SCREW, M4x10MM, 10.9 STEEL, BLACK	OVERTOP		1 Apply grease on screw threads
54	1	SCREW	1802012 UDH STOP SCREW M4X8	OVERTOP		2 Apply loctite 243 (Blue) on screw threads
55	7	SCREW	1804060 M4X0.7, 10MM, 2.5 HEX, BUTTON HEAD, SS, BLACK	OVERTOP		1 Apply grease on screw threads
56	5	SCREW	1804063 LOW PROFILE SOCKET HEAD SCREW, M5X10, STAINLESS STEEL, BLACK	OVERTOP		2 Apply grease on screw threads
57	2	SCREW	1804065 M6 X 14MM, LOW BUTTON HEAD SCREW, SS, BLACK COATED	OVERTOP		4 Dry installation
58	2	SCREW	1805077-BK C'SUNK SOCKET SCREW, M4X16, STAINLESS STEEL, BLACK	OVERTOP		1 Apply grease on screw threads
59	1	SCREW	1805157 MOTOR MOUNTING SCREW, M8x1.25, 10 MM L, 304 SS, BUTTON HEAD	OVERTOP		10 Apply Loctite 243 (blue) on screw threads
60	5	SCREW	1805158 MOTOR MOUNTING SCREW, M8x1.25, 18 MM L, 304 SS, BUTTON HEAD	OVERTOP		14 Apply Loctite 243 (Blue) on screw threads
61	6	SCREW	1805160 SCREW, BUTTON HEAD, 18-8 SS, BLACK, M3X0.5, L:8MM	OVERTOP		0.5 Apply grease on screw threads
62	1	SCREW	1805170 SCREW, BUTTON HEAD, 18-8 SS, RAW STAINLESS, M6X1.0, 12MM LENGTH	OVERTOP		4 Dry installation
63	2	SCREW	1805171 SCREW, BUTTON HEAD, 18-8 SS, BLACK, M6X1.0, 25MM LENGTH	OVERTOP		8 Apply loctite 243 (Blue) on screw threads
64	1	SCREW, M4X20	1809011 C'SUNK SOCKET SCREW, M4x20mm, STAINLESS STEEL 316	OVERTOP		2 Apply loctite 243 (Blue) on screw threads
65	1	SCREW, M5X12	1807152 C'SUNK SOCKET SCREW, M5-0.8x12mm. STAINLESS BLACK	OVERTOP		2 Apply loctite 243 (Blue) on threads
66	1	SEATSTAYS	SEE TABLE SEATSTAYS - MY25 INSTINCT POWERPLAY	MK (RANBOW)		
67	1	SHOCK BUSHING	N/A SHOCK BUSHING, ID:12.7mm, OD:15mm, L:12.7mm, STEEL			
68	2	SHOCK REDUCER	N/A FOX STD REDUCER FOR 25MM PIN			
69	2	SHOCK REDUCER	N/A SRAM STD REDUCER FOR 25MM PIN			
70	1	SHOCK, PIN	N/A SHOCK PIN: ID:8 x 25 mm LONG; ALUMINUM			
71	1	SLEEVE	1800008 TT BEARING SLEEVE, ID:10, OD:14, L:29	OVERTOP		
72	1	SLEEVE	1800010 SS BEARING SLEEVE, ID:10, OD:14, L:41, NECKED	OVERTOP		
73	2	SLEEVE	1800040 DROPOUT BEARING SLEEVE, OD:14, ID:8, T:1.8, 6061 ALU	OVERTOP		

## LISTE DES PIÈCES ET INSTRUCTIONS D'ASSEMBLAGE

74	1 SLEEVE	1805156 SLEEVE, MAIN PIVOT, 10MM ID, 52.5 MM L	OVERTOP	Grease bearing contact surfaces before installation
75	1 SLEEVE	1807028 BEARING EYELET CENTRE SLEEVE	OVERTOP	
76	1 SPACER	1347013 CHAINSTAY PULLEY GUIDE SPACER,	OVERTOP	
77	4 SPACER	1800009 LINK BEARING SPACER, OD:22, ID:10, T:2.5	OVERTOP	
78	4 SPACER	1800039 DO BEARING SPACER, OD:16, ID:8, T:1.75, 6061 ALU	OVERTOP	
79	2 SPACER	1805191 CHAINGUIDE SPACER, 0.5MM, 304 STAINLESS STEEL, 2025 IPP	OVERTOP	
80	1 SPACER	3399006 LOWER CHAIN GUIDE SPACER	SHING FONG	
81	3 WASHER	1800019 WASHERID: 10.2, OD: 15.5, T:1	OVERTOP	
82	1 WASHER	1801009 WASHER, 20X24X0.5MM, 304 SS	OVERTOP	
83	2 WASHER	1805155 WASHER, MAIN PIVOT, 15MM ID, 27.5MM OD, 2.5MM T	OVERTOP	
84	3 WASHER	1805172 WASHER, 6x10x0.5MM, 304 SS	OVERTOP	
85	1 WASHER	3227006 WASHER, 12x19x0.5MM, 304 SS	OVERTOP	

## IMAGES



## JUMBOTRON

L'écran du Jumbotron est le centre de communication de votre vélo Powerplay<sup>MC</sup>. Il sert à faire fonctionner le système, à afficher des renseignements et à diagnostiquer et à réparer des problèmes. Le micrologiciel sera mis à jour au besoin lorsque le vélo sera connecté à un ordinateur par le port USB.



## RÉGLAGES DU RIDER

### IPM (interface pouce-machine, alias la télécommande)



### ÉCRAN

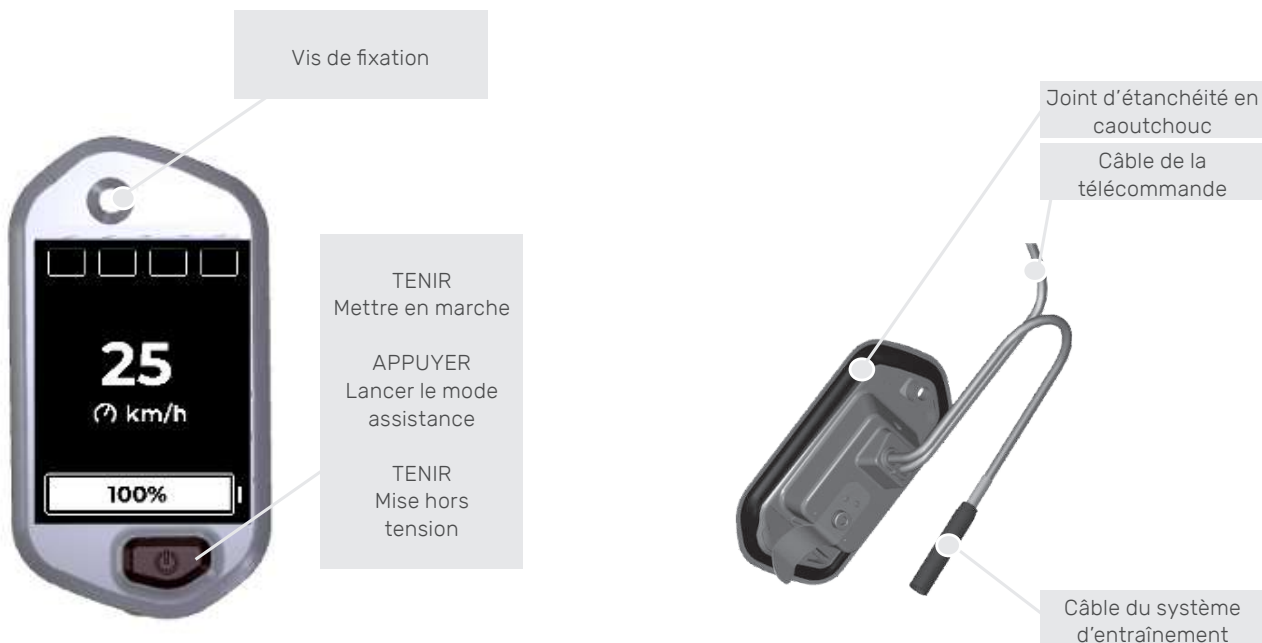

## UTILISATION DU VÉLO

### Avertissement

Il faut appliquer les freins avant d'appuyer sur les pédales, et même avant d'y poser le pied. Le vélo Powerplay<sup>MC</sup> est équipé d'une technologie de démarrage instantané, qui lui donne une puissance immédiate, naturelle et tout en douceur grâce à un capteur de couple perfectionné. Ce circuit étant très sensible, vous devez prendre des précautions pour éviter que le vélo démarre sans vous.

### Mise en marche

Pour mettre en marche le système d'entraînement Powerplay<sup>MC</sup>, allumez le vélo en maintenant le bouton du Jumbotron enfoncé pendant 2 secondes. N.B. : Le système d'entraînement Powerplay<sup>MC</sup> se met en marche par défaut au deuxième degré d'assistance le plus bas, que vous pouvez ensuite augmenter avec la télécommande ou le Jumbotron.

### Degrés d'assistance

Le système d'entraînement Powerplay<sup>MC</sup> offre plusieurs degrés d'assistance.

#### Degré 1 : Eco

C'est le degré de puissance le plus bas : l'autonomie de la batterie est grande et le rider a beaucoup d'efforts à fournir.

#### Degré 2 : Trail

Idéal pour rouler dans les sentiers, ce degré d'assistance offre un bon équilibre entre autonomie et puissance.

#### Degré 3 : Trail +

Ce degré fournit assez de puissance pour assurer une conduite excitante, et une bonne vitesse pour que vous arriviez aux descentes sans avoir vidé la batterie.

#### Degré 4 : Ludicrous

Pour une vitesse maximale et un degré d'assistance élevé, ce mode confère une très grande puissance à la roue arrière. Notez cependant que son utilisation prolongée décharge assez rapidement la batterie. Pour modifier le degré d'assistance, utilisez la télécommande (bouton « Haut » ou « Bas ») ou appuyez sur le bouton du Jumbotron.

N.B. : VOUS POUVEZ PERSONNALISER LES 4 DEGRÉS D'ASSISTANCE ET LA PROPULSION DU MOTEUR (SENSIBILITÉ DU COUPLE) À PARTIR DU MENU PRINCIPAL. BOUTON  ENFONCÉ POUR Y ACCÉDER

## UTILISATION DU VÉLO

Le système d'entraînement Dynamé S4 Lite est doté d'un mode enfant réglable, qui permet aux parents de fixer une limite de vitesse et de puissance pour le Instinct Powerplay SL.

Pour activer le MODE ENFANT, tenir le bouton ⚡ enfoncé sur la microtélécommande et accéder aux réglages.

### MENU du mode enfant

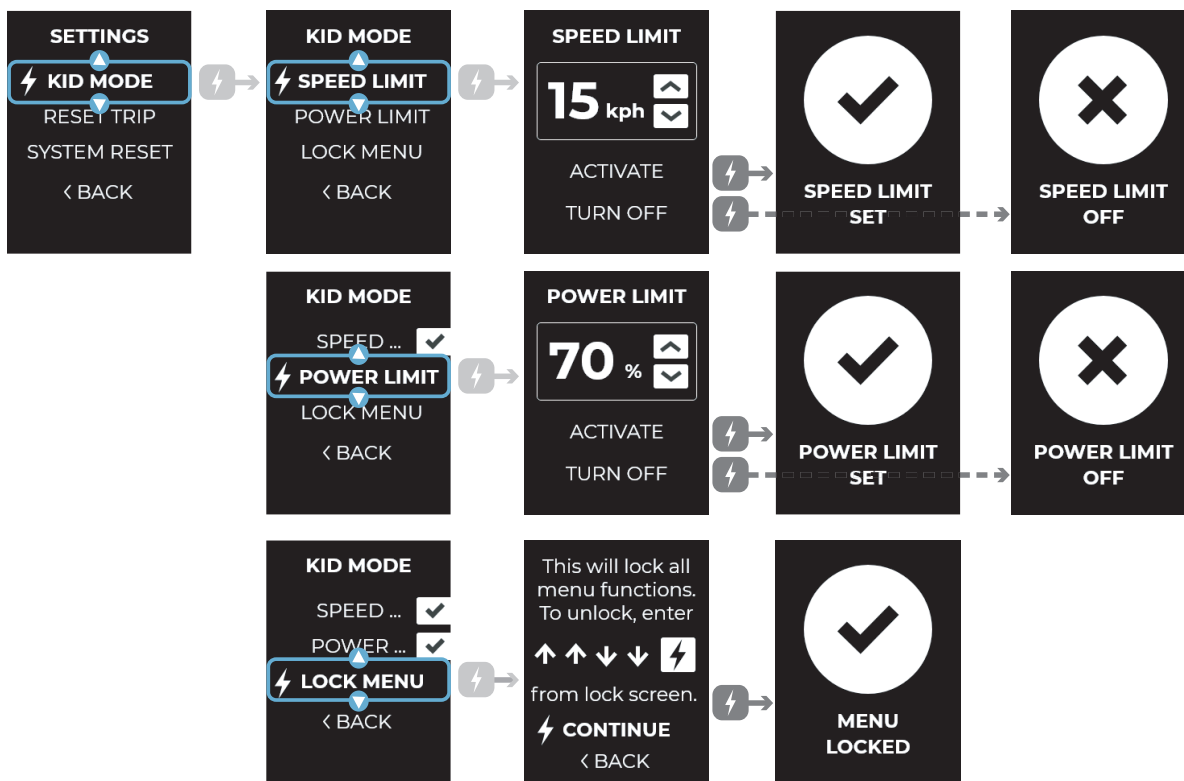

#### Une fois verrouillé



Si l'on appuie sur le bouton du menu, l'écran de menu verrouillé s'affiche. L'image disparaît si aucun code n'est saisi après cinq secondes.

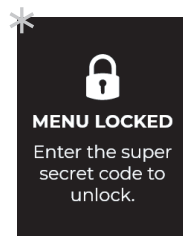

#### Séquence de déverrouillage



Si cette séquence est entrée, le menu d'écran déverrouillé s'affiche et les fonctions du menu normal sont accessibles.



## RÉGLAGE DE L'ASSISTANCE

Le degré d'assistance peut être choisi ou personnalisé dès le début du trajet ou à tout moment pendant la sortie. Le système Dynam<sup>MC</sup> 4.0 garde en mémoire jusqu'à trois réglages : le réglage d'origine et deux réglages personnalisables. Le choix du réglage dépend de la réponse voulue.

### Sélection du réglage

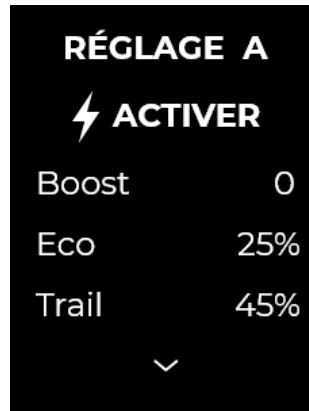
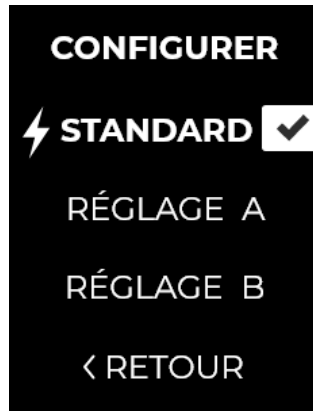

### Ajustement des réglages

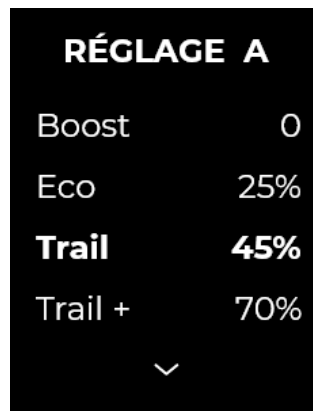
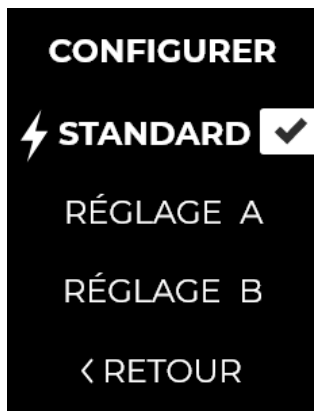

#### 2 paramètres réglables

- Boost : Réponse du moteur à l'impulsion donnée par le rider (sensibilité du couple ou % de propulsion).

- Mode d'assistance : % de puissance des quatre degrés d'assistance.

## RÉGLAGE DE L'ASSISTANCE

### Propulsion du moteur



#### Adjust from +2 to -2

- +2** Très peu d'efforts à fournir. Propulsion maximale, autonomie minimale : filez à toute allure!
- 0** Équilibre entre propulsion et autonomie.
- 2** Effort considérable à fournir, autonomie maximale : meilleur entraînement.

### Puissance des degrés d'assistance

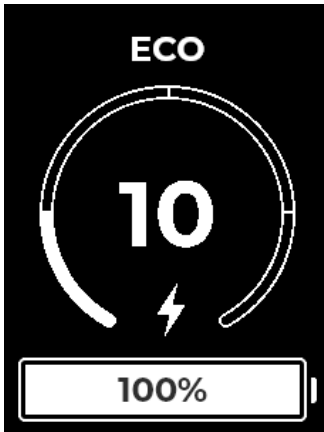

#### Réglage de 1 % à 100 %

Choix de la puissance de chacun des quatre degrés d'assistance (Eco, Trail, Trail +, Ludicrous), soit le pourcentage de la puissance maximale disponible. Il est impossible de régler la puissance d'un degré d'assistance à une valeur plus basse que celle d'un degré d'assistance inférieur (p. ex., le pourcentage attribué au degré Trail ne peut être inférieur à celui du degré Eco).

## BATTERIE

Les commandes, les moteurs et les composants de batterie des modèles Instinct Powerplay SL sont exclusifs. Parfois sensibles, ils doivent être manipulés avec précaution. Nous souhaitons que vous ayez le plus d'information possible : veuillez donc prendre note des nouveaux renseignements suivants concernant la batterie, la recharge et l'entretien du système Powerplay<sup>MC</sup> de Rocky Mountain. Le non-respect des directives de cette section du guide peut endommager les composants électriques de votre vélo, annuler la garantie et, surtout, entraîner des blessures graves, voire mortelles.

### Généralités

- Les batteries des appareils Powerplay<sup>MC</sup> de Rocky Mountain ont toutes les certifications nécessaires et sont munies d'un système de gestion qui offre plusieurs niveaux de protection pour prévenir les dangers. Malgré ces mesures de sécurité, une batterie chargée qui atteint une température extrême ou un port de chargement endommagé peuvent être dangereux et causer des décharges électriques, des incendies ou des blessures.
- Si votre batterie ou votre chargeur semblent endommagés de quelque manière que ce soit, ne les utilisez pas et apportez-les immédiatement chez votre détaillant Rocky Mountain autorisé pour les faire inspecter.
- L'entretien de la batterie, du mécanisme d'entraînement, ainsi que de tout composant exclusif du système Powerplay<sup>MC</sup> devrait être effectué uniquement par un mécanicien ayant suivi la formation de Rocky Mountain sur ce système.
- Ne laissez jamais d'objet petit, tranchant ou métallique entrer en contact avec la batterie ou sa prise de recharge.
- Ne tentez jamais de modifier, d'ouvrir ou de démonter la batterie ou le chargeur.
- Ne nettoyez jamais votre Instinct Powerplay SL avec un nettoyeur à haute pression, et ne l'immergez jamais dans l'eau. La pluie et le nettoyage ordinaire ne causeront pas de problème.
- En bon état, les batteries ne libèrent pas de liquides ni de gaz, mais une batterie endommagée peut libérer du liquide irritant ou corrosif pour la peau, et des gaz irritants pour les voies respiratoires. En cas de contact cutané ou oculaire avec le liquide, rincez immédiatement à l'eau et consultez un médecin.
- Si vous transportez votre vélo par voiture et que vous en retirez la batterie, recouvrez toutes les connexions pour éviter que du gravier, de l'eau ou du sel s'y introduise.
- En cas d'incendie de la batterie, ne versez pas d'eau directement sur celle-ci. Il est possible d'utiliser de l'eau pour éteindre le feu sur les matériaux autour de la batterie, mais pas sur les cellules chimiques de la batterie. Pour éteindre correctement le feu, utilisez un extincteur de classe ABC ou BC. Il est également possible d'utiliser du sable pour bien étouffer le feu. Si possible, sans vous exposer à un risque de blessure, déplacez la batterie chaude ou enflammée ou la bicyclette entière à l'extérieur pour éviter que le feu ne se propage. Si la batterie est branchée sur un chargeur, il est primordial de la débrancher en premier lieu ou de couper le courant.

### Recharge

- Utilisez uniquement les chargeurs Rocky Mountain conçus pour recharger les batteries Powerplay<sup>MC</sup>.
- Ne laissez pas le chargeur exposé à la lumière directe du soleil, en particulier durant la recharge.

### To recharge the battery

1. Trouvez le port de chargement sur le vélo Instinct Powerplay SL et enlevez le capuchon.
2. Notez la forme du connecteur du câble de recharge, puis orientez le connecteur dans le bon sens pour brancher le chargeur sur le port de chargement du vélo Powerplay<sup>MC</sup>.
3. Branchez le chargeur sur une prise électrique. Le voyant à DEL du chargeur s'allumera en rouge pour indiquer que la batterie se recharge.



## BATTERIE

4. Lorsque la batterie est presque complètement chargée, le système ralentira la vitesse de chargement afin de bien recharger et d'équilibrer les cellules. Le chargeur peut allumer successivement les voyants DEL de « charge incomplète » (rouge) et de « pleine charge » (vert) toutes les 30 secondes pendant 30 minutes. Si le voyant DEL vert reste allumé pendant plus de 5 minutes, la batterie est entièrement chargée. Il n'est pas nécessaire de débrancher le chargeur immédiatement une fois la recharge terminée, mais il n'est pas recommandé de laisser le vélo branché plus de 12 heures.

### NOTES:

1. Ne confondez pas le signal de fin de charge avec le signal de défaillance du système (clignotement rapide du chargeur).
  2. La fin de charge représente les derniers 3 % de charge de la batterie. Si vous êtes satisfait du niveau de charge, vous pouvez débrancher le chargeur à tout moment.
    - Chargez le vélo Powerplay<sup>MC</sup> dans un endroit ouvert offrant un accès dégagé vers une sortie extérieure.
    - Comme pour tous les vélos et équipements munis de batteries au lithium-ion, il est recommandé de ne jamais recharger le vélo sans surveillance.
    - Si la batterie atteint 50 °C (122 °F), la recharge sera interrompue jusqu'à ce que la température redescende à 45 °C (113 °F). Si la batterie atteint 0 °C (32 °F), la recharge sera interrompue jusqu'à ce que la température remonte à 3 °C (37,4 °F).
    - Le temps de recharge varie en fonction de la charge restante.
- Les temps de recharge sont les suivants :

480 Wh	4A Charger	2A Charger
Temps de recharge de 0-80 %	1h55	4h00
Temps de recharge de 0-95%	2h20	4h40
Temps de recharge totale de 0-100%	2h35	5h05

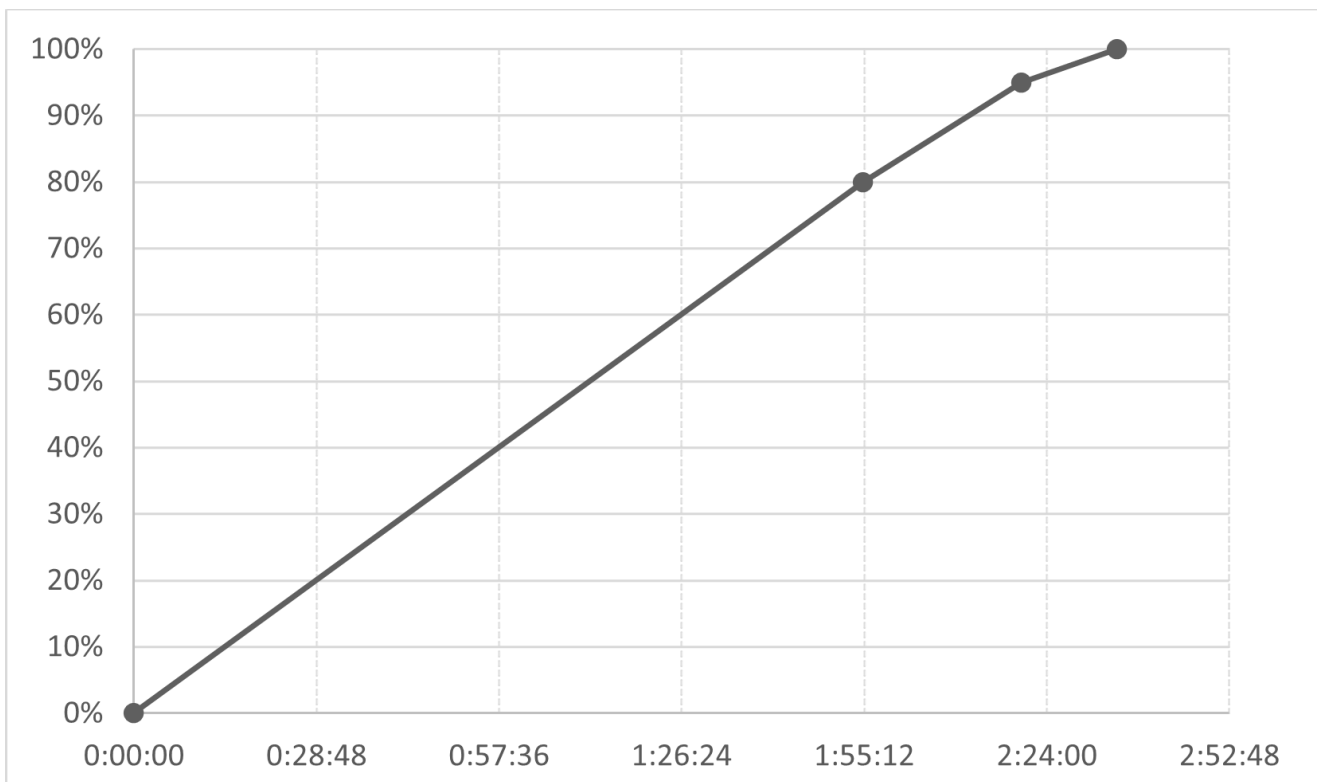

## BATTERIE

### Rangement

- Pour remettre le vélo Powerplay<sup>MC</sup>, laissez-le dans un endroit qui n'est pas exposé aux températures extrêmes (supérieures à 30 °C [86 °F] ou inférieures à -20 °C [-4 °F]), ou sujet à une exposition excessive au soleil, à l'humidité ou à la condensation. Si vous croyez que votre vélo a été entreposé dans l'une des conditions énumérées ci-haut, veuillez en cesser immédiatement l'utilisation et contactez votre détaillant Rocky Mountain autorisé.
- Le remisage d'une batterie complètement déchargée pendant une période prolongée peut causer des dommages et diminuer sa capacité. Il est recommandé de déconnecter la batterie avant un stockage à long terme qui dépasse 2 semaines. Il est également recommandé de recharger la batterie à au moins 75 % de sa capacité chaque fois que possible afin d'éviter les dommages causés par une décharge profonde pendant des périodes de stockage prolongées de plus de 2 semaines.
- Si le vélo est entreposé longtemps, il faut recharger la batterie régulièrement (au moins une fois tous les trois mois) pour conserver sa capacité et éviter qu'elle s'endommage. Un truc pour ne pas l'oublier : programmer des rappels sur un ordinateur ou un appareil mobile.
- Une pratique exemplaire pour préserver la capacité de la batterie consiste à entreposer le vélo à des températures entre 10 °C (50 °F) et 25 °C (77 °F) et à un taux d'humidité relative inférieur à 65 %.
- Après un mois de stockage, la batterie entre en mode de protection. Pour réactiver la batterie, veuillez la brancher sur le chargeur.

### Fonctionnalité de la batterie

- La batterie fonctionne par temps froid, mais à capacité réduite. On peut s'attendre à 70 % de la capacité maximale à -10 °C (14 °F). Il est recommandé de réchauffer le vélo avant de l'utiliser s'il est froid.
- Si la batterie atteint 65 °C (149 °F), elle cessera de fonctionner par mesure de protection jusqu'à ce qu'elle redescende sous 60 °C (140 °F). Elle cessera aussi de fonctionner par mesure de protection si elle atteint -20 °C (-4 °F) jusqu'à ce que sa température remonte à -15 °C (5 °F).
- Lorsque la capacité résiduelle de la batterie est faible, le système d'entraînement Powerplay<sup>MC</sup> réduit progressivement sa puissance de sortie pour maximiser son autonomie.
- Notez que les batteries lithium-ion perdent progressivement leur capacité en fonction de leur âge et de leur utilisation. Une diminution importante de la capacité peut indiquer que la batterie approche de sa fin de vie utile et doit être remplacée. Visitez votre détaillant autorisé Rocky Mountain pour effectuer le remplacement de la batterie. Sous des conditions normales d'utilisation, vous pouvez espérer :

#### 4800 Wh

80 % de sa capacité après 500 cycles de charge complets  
(de 0 % à 100 %).

## BATTERIE

### Voyant à DEL de la batterie

- Pendant la recharge

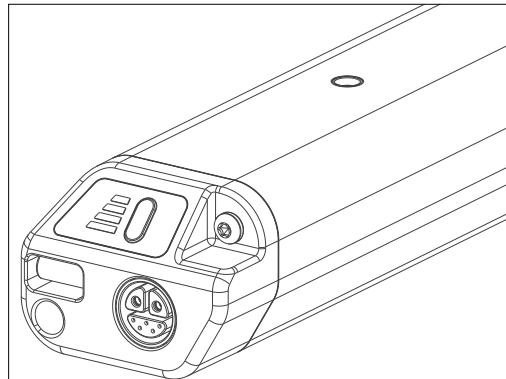

### Indicateur du niveau de la batterie

- **Appuyer rapidement sur le bouton de capacité**  
Appuyer sur le bouton pendant moins d'une seconde lorsqu'en marche.

#### INDICATEUR DE CAPACITÉ DE LA BATTERIE (LED 4,3,2,1)

#### Capacité de la batterie restante

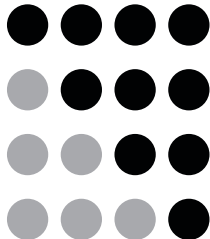

100%-75%

74,9%-50%

49,9%-25%

24,9%-0%

- **Indicateur de recharge en cours**

#### INDICATEUR DE CAPACITÉ DE LA BATTERIE (LED 4,3,2,1)

#### Capacité de la batterie

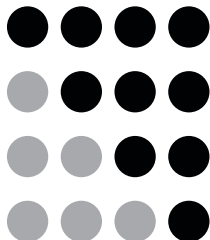

100%-75%

74,9%-50%

49,9%-25%

24,9%-0%

● : Éteint

● : Allumé

☀ : Clignotant

## ÉCRANS DU RIDER

Selon la sélection, l'écran affiche un type d'information tout en montrant les données importantes. Cet écran affiche l'information pertinente pour une course, comme la vitesse, la cadence, le degré d'assistance et le niveau de puissance.

### Écrans de course

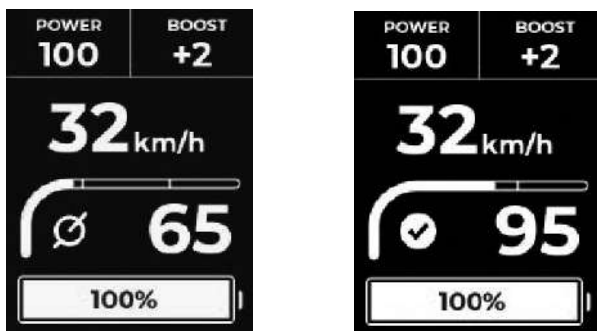

### Affichage de la vitesse

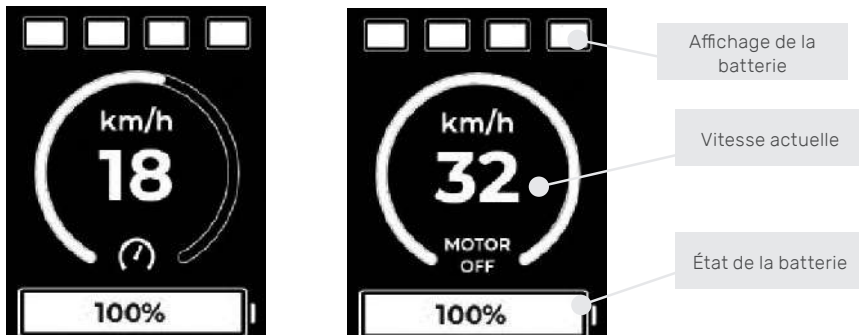

### Affichage de la batterie

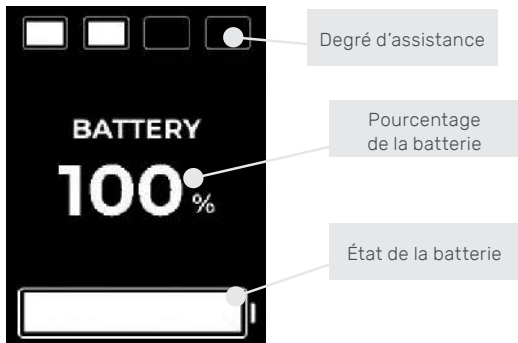

## ÉCRANS DU RIDER

### Affichage de l'assistance

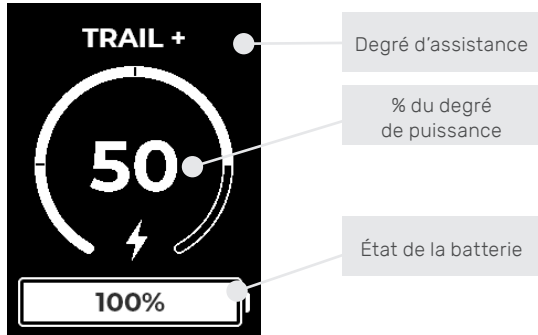

### Affichage de la cadence

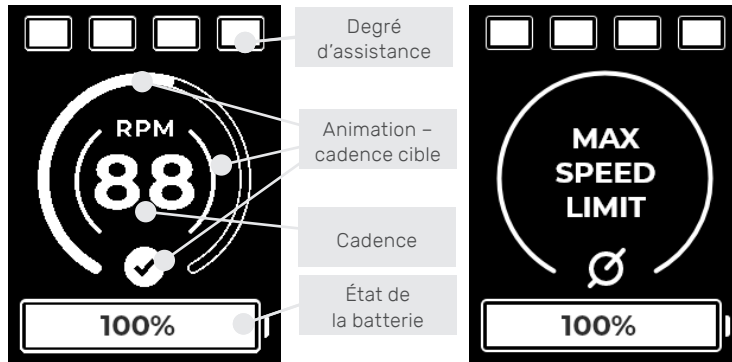

À noter que la cadence est évaluée selon le nombre de tr/min du moteur et qu'il s'agit d'une estimation. Ainsi, lorsque le moteur est arrêté (ex. : au-dessus de la vitesse maximale), la cadence n'est pas mesurée.

### Affichage de l'odomètre

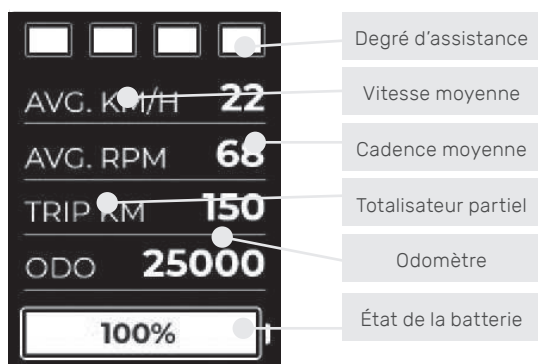

## RÉINITIALISATION

Les données sur le trajet (vitesse moyenne, cadence moyenne, distance) peuvent être réinitialisées en tout temps, et le système Dynamé peut être restauré aux paramètres par défaut.

### Réinitialisation du trajet

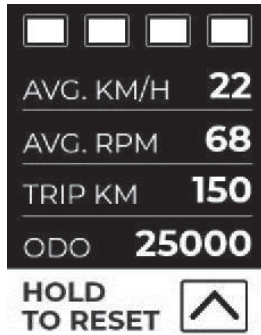

Dans l'affichage de l'odomètre, maintenez le bouton « Haut » sur la télécommande.

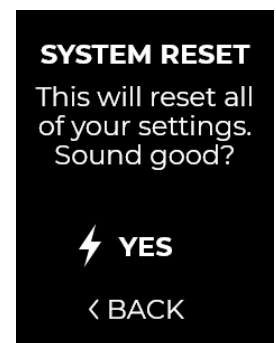
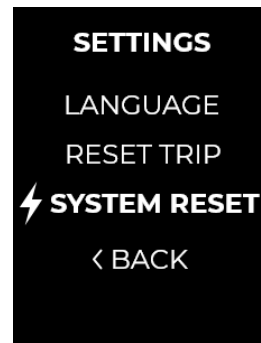
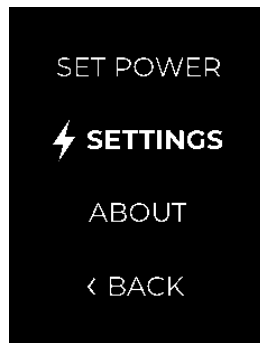

À partir de n'importe quel écran, ouvrez le menu principal en maintenant le bouton ⚡ enfoncé. Sélectionnez Paramètres, puis Réinitialiser système.

### Mode marche

Le système d'entraînement Powerplay<sup>MC</sup> est doté d'un mode marche pour vous aider à faire avancer le vélo en marchant. Sur la télécommande, maintenez le bouton « Bas » enfoncé pour propulser doucement le vélo lorsque vous le poussez. Vous ne pouvez pas utiliser le mode marche pendant que vous êtes sur le vélo. Vous devez marcher à côté.

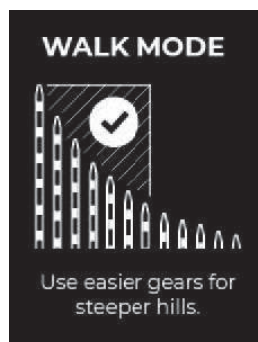

### Mise hors tension

Pour mettre le système d'entraînement Powerplay<sup>MC</sup> hors tension, maintenez le bouton du Jumbotron enfoncé. Si le vélo est immobile pendant 10 minutes, le système s'éteint automatiquement pour conserver la charge de la batterie.

### Message

S'affiche si le bouton d'activation est enfoncé pendant 0,5 seconde.



### Mise hors tension

S'affiche si le bouton d'activation est enfoncé pendant 2,5 secondes.

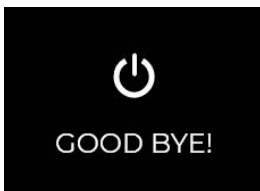

## NOTES

### Télécommande endommagée

Si la télécommande est endommagée et ne fonctionne plus, vous pouvez continuer de faire du vélo au degré d'assistance voulu avec le Jumbotron.

*NOTE: The menus and adjustments are not accessible via the Jumbotron, without the remote.*

### Autonomie

La distance pouvant être parcourue avec la fonction de pédalage assisté varie selon plusieurs facteurs : degré d'assistance, température ambiante, propulsion du moteur, vitesse d'accélération, résistance au vent, qualité de l'entretien, âge de la batterie, relief du terrain (montées, obstacles) et poids du cycliste.

### Conseils de conduite

- Le système d'entraînement Dynamé S4 Lite donne une puissance naturelle et tout en douceur à la roue arrière; il fonctionnera mieux si vous suivez les consignes suivantes.
- Privilégiez un pédalage doux et constant plutôt qu'un coup de pédale raide.
- Changez fréquemment de vitesse pour maintenir une cadence de 80 à 120 tr/min et ainsi optimiser l'efficacité du moteur, ce qui se traduit par un couple élevé et un rendement maximal de la batterie. Vérifiez votre cadence sur le Jumbotron pour connaître l'efficacité de votre pédalage.
- Faites attention lors des changements de vitesse :
  - Diminuez la pression sur les pédales avant un changement pour éviter de soumettre la chaîne à une tension.
  - Ne changez pas plus d'une vitesse à la fois.

## ENTRETIEN

### Diagnostic et réparation

Le Jumbotron affiche des messages d'erreur et donne des instructions de réparation dans certains cas.

#### Exemple



### Étalonnage

L'étalonnage pourrait parfois être requis pour maintenir la performance du système d'entraînement. Généralement, on l'effectue chaque fois qu'un composant de la transmission (chaîne, plateau, pignon d'entraînement, etc.) est remplacé ou que le moteur est réinstallé sur le cadre.

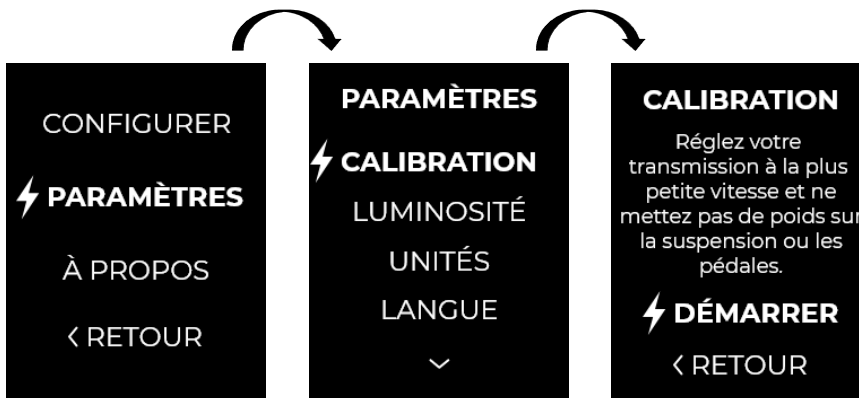

## SERVICE

### Dépannage

Veillez demander l'aide de votre détaillant pour résoudre les problèmes. L'écran du Jumbotron peut générer des codes d'erreur pour faciliter le diagnostic. Lorsqu'un code d'erreur apparaît, le système donne des instructions. Dans certains cas, il est possible de faire une réparation sur-le-champ, mais il pourrait parfois être nécessaire de se rendre chez un détaillant autorisé. Certaines erreurs activent un mode ralenti qui vous permet de retourner à la maison à basse puissance.

### Avertissement

**AVERTISSEMENT :** N'altérez pas votre vélo Rocky Mountain. L'altération consiste à retirer ou à remplacer une pièce originale de votre vélo Rocky Mountain ou à en modifier d'une quelconque façon la conception ou le fonctionnement. Ce faisant, vous risqueriez de nuire grandement à la maniabilité, à la stabilité et à d'autres aspects du vélo, rendant sa conduite dangereuse. L'altération peut annuler la garantie et rendre votre vélo Rocky Mountain non conforme aux lois et aux règlements en vigueur à son lieu d'utilisation. Pour assurer la sécurité, la qualité et la fiabilité, n'utilisez que des pièces originales ou autorisées par Rocky Mountain Bicycles pour faire les réparations ou le remplacement. Rocky Mountain Bicycles n'est responsable d'aucun dommage direct, connexe ou consécutif, notamment les blessures, les dommages matériels ou les pertes financières causés par l'altération.

#### *Attention :*

Le niveau de pression acoustique mesuré en décibels pondérés A aux oreilles de l'utilisateur est de moins de 70 dB(A).



## ENTRETIEN GÉNÉRALE

Sachez que les composants des vélos à assistance électrique subissent une tension et une contrainte plus grandes que ceux des vélos de montagne traditionnels. Ils doivent donc être inspectés et entretenus plus fréquemment pour optimiser leur sécurité, leur performance et leur durabilité.

### Recharge hors saison

Si vous entreposez le vélo pour une longue période, n'oubliez pas de recharger la batterie au moins une fois tous les trois mois. Sinon, elle risque de s'endommager, et sa capacité pourrait diminuer. Après un mois d'entreposage, la batterie entrera en mode de protection. Pour la sortir de ce mode, branchez-la sur le chargeur.

Un bon moyen de ne pas oublier la recharge consiste à programmer des rappels sur un ordinateur ou un appareil mobile.

### Nettoyage

L'idéal est de garder son vélo bien propre. La meilleure méthode pour le nettoyer est d'utiliser de l'eau chaude savonneuse. N'utilisez pas de nettoyeur à pression.

N.B. : N'aspergez jamais directement les composants électriques.

### Entretien préventif

Nettoyez la transmission et inspectez-la pour vous assurer qu'elle est exempte d'usure.

- Chaîne
- Cassette
- Galets (inférieur, dérailleur)
- Plateau
- Pignon d'entraînement

Examinez les vis et fixations

- Fixations habituelles sur un vélo (pivots, potence, vis de pédalier, vis de plateau)
- Supports du moteur
- Support du capteur de couple
- Goupille de sûreté pour la batterie
- Tension des rayons
- Plaquettes et disques de freins
- Propreté et protection du port de chargement

## ENTRETIEN GÉNÉRALE

Entretien et ajustement périodiques	Liste de vérification					Notes
	500KM	1000KM	1500KM	2000KM	2500KM	
<b>Chaîne - inspection de l'usure, nettoyage et lubrification</b>	Avant chaque sortie					Vérifier l'état (étirement, fissures) et lubrifier la chaîne avec le lubrifiant recommandé par le fabricant.
<b>Port de chargement</b>	Avant chaque recharge					Vérifier l'infiltration d'eau, la corrosion, l'alignement des broches et la saleté
<b>Capteur de couple - étalonnage</b>	Tous les deux mois					OU à chaque remplacement d'un composant du système d'entraînement ou de la transmission
<b>Vis de fixation du moteur</b>	●	●	●	●	●	Vérifier le couple
<b>Pignon d'entraînement et contre-écrou</b>	●	●	●	●	●	Vérifier l'état; les remplacer s'ils sont trop usés
<b>Capteur de couple et galet tendeur</b>	●	●	●	●	●	Vérifier la présence de fissures ou de dommages
<b>Boîtier et couvercle du moteur</b>		●		●		Vérifier la présence de fissures ou de dommages
<b>Câbles du moteur</b>		●		●		Vérifier l'isolation et l'état des connecteurs
<b>Boîtier de la batterie</b>	Chaque fois que la batterie n'est pas sur le vélo					Vérifier si le boîtier et le connecteur sont endommagés
<b>Télécommande et câble du guidon</b>	●	●	●	●	●	Vérifier si le boîtier et le connecteur sont endommagés
<b>Écran et câble sur le tube horizontal display &amp; câble</b>	●	●	●	●	●	Vérifier s'il y a un jeu excessif ou si l'écran est endommagé
<b>Câble du tube diagonal</b>	●	●	●	●	●	Vérifier si le boîtier et le connecteur sont endommagés
<b>Capteur de vitesse et fil</b>	Chaque fois que la roue est retirée du vélo					Vérifier si le boîtier et le connecteur sont endommagés et si les aimants sont bien fixés
<b>Chaîne - nettoyage et lubrification</b>		●		●		Vérifier l'état et lubrifier la chaîne avec la même huile que pour la chaîne de la transmission
<b>Chaîne - remplacement</b>	Tous les 2 500 km					Vérifier l'état pour prévenir l'usure à l'intérieur du moteur et le bruit
<b>Butée de débrayage du moteur - remplacement</b>	Tous les 2 500 km					Vérifier que le débrayage se fait en douceur
<b>Étoile d'embrayage - Remplacement</b>	Tous les 2 500 km					Vérifier que l'embrayage se fait en douceur

## ENTRETIEN GÉNÉRALE

### PIÈCES ET ACCESSOIRES DE REMPLACEMENT

Vous devez vous procurer les pièces et accessoires de remplacement de Rocky Mountain auprès de votre détaillant autorisé. Nous vous recommandons fortement de transporter une chambre à air de rechange et les outils pour la poser lorsque vous utilisez votre vélo.

### TRANSPORT

Le transport et l'expédition d'un vélo doté du système d'entraînement Powerplay<sup>MC</sup> peuvent être soumis à des restrictions et nécessiter un traitement spécial en ce qui concerne la manutention, l'étiquetage et l'emballage. Prenez soin de bien vous renseigner à l'avance sur la réglementation en vigueur dans votre pays. Si vous transportez votre vélo par voiture et que vous en retirez la batterie, recouvrez toutes les connexions pour éviter que du gravier, de l'eau ou du sel s'y introduise.

### ENREGISTREMENT

L'enregistrement de votre vélo marque votre entrée officielle dans la famille Rocky Mountain, et c'est une étape importante pour en activer la garantie. Ainsi, en cas de besoin, nous pourrions traiter le problème efficacement pour vous faire remonter en selle aussitôt que possible. L'enregistrement est facile et ne prend que quelques minutes.

Register your bike: [bikes.com/register](https://bikes.com/register)

## GARANTIE

Votre Rocky Mountain Instinct Powerplay SL™ est couvert par une garantie contre les défauts de matériaux et de fabrication, conformément au tableau suivant :

CATÉGORIE	DURÉE	NOTES
Cadre	5 ans	Triangles avant et arrière, maillons
Quincaillerie	1 an	Pivots, axes, etc.
Paint & decals	1 year	Pivots, axes, etc.
Jante en carbone de marque Rocky Mountain	2 ans	Garantie de remplacement sans défaut de 2 ans, après 2 ans, la jante est remplacée pour une fraction du prix de vente au détail* *La garantie ne couvre pas les coûts de main-d'œuvre et les frais d'expédition
Composants électroniques	3 ans	Système d'entraînement, télécommande, Jumbotron, capteurs, chargeur
Pièces de la transmission exposées à l'usure	1 an	Galets, pignons, chaîne
Batterie	24 mois	<p>Le système d'entraînement Powerplay<sup>MC</sup> fera progressivement diminuer le degré d'assistance à mesure que la batterie se décharge afin de fonctionner le plus longtemps possible.</p> <p>L'autonomie varie selon plusieurs facteurs : degré d'assistance, température ambiante, accélération, résistance au vent, qualité de l'entretien, âge de la batterie, relief du terrain (montées, obstacles) et poids du cycliste.</p> <p>Si le vélo est entreposé pour trois mois ou plus, chargez la batterie au moins tous les trois mois. Le non-respect de cette directive peut endommager la batterie et annule la garantie.</p>
Autres pièces	Selon la garantie du fabricant	

Toute garantie et service après-vente doivent être gérés par le détaillant Rocky Mountain autorisé qui a vendu le vélo ou le cadre complet. Nous couvrons votre cadre Rocky Mountain à compter de la date d'achat originale de votre nouveau vélo contre les défauts de matériaux et de fabrication, selon le matériau du cadre et le type d'utilisation faite du vélo. La garantie limitée de Rocky Mountain couvre également les vélos précédemment utilisés à des fins personnelles et commerciales telles que la location (y compris dans les parcs à vélos), les services de messagerie, la police, la sécurité, etc., contre les défauts de matériaux et de fabrication. La garantie limitée s'applique pour le reste de la période de garantie à compter de la date d'achat initiale auprès de Rocky Mountain. Dans de tels cas, la quincaillerie, les roulements, les pivots et les bagues sont exclus de notre politique de garantie. Le reçu de vente original, la confirmation d'enregistrement du vélo ou toute autre preuve d'achat est requis pour toute réclamation. Pour les vélos 2021 et plus récents, la garantie limitée d'origine est transférable aux propriétaires subséquents. Pour que la garantie limitée s'applique, l'enregistrement du vélo doit être effectué en ligne à la fois par le propriétaire original et par le propriétaire subséquent. La facture originale ne sera pas exigée pour le propriétaire subséquent.

### **Veillez enregistrer le vélo pour transférer la garantie.**

#### **Matériau du cadre/Type d'utilisation**

- Fibre de carbone : Garantie limitée de 5 ans\*
- Aluminium – suspension avant et double suspension : Garantie limitée de 5 ans\*

\* Les limites sont décrites plus loin.

#### **Autre couverture de garantie contre les défauts de fabrication et de matériaux**

- Revêtement – peinture et autocollants : 1 an
- Quincaillerie du cadre, pivots de suspension et bagues : 1 an

\*Les liens font partie du cadre le vélo pour transférer la garantie.

[bikes.com/registration](https://bikes.com/registration)

## GARANTIE

### NOTES

#### La garantie n'est plus valide dans les cas suivants:

- Installation et utilisation de composants, pièces ou accessoires non initialement destinés ou compatibles avec le vélo (ou le cadre) tel que vendu.
- Acheter un vélo Rocky Mountain ou utiliser des sites Internet tiers (comme eBay), peu importe ce que dit l'annonce.
- La décoloration de la peinture causée par les effets de la lumière ultraviolette (UV) ou de l'exposition extérieure n'est pas couverte par cette garantie limitée.
- Rocky Mountain ne garantit aucun dommage causé à votre vélo lors de l'installation ou du retrait de tout film protecteur.
- Les rayures ou éclats de peinture causés par la saleté, les cailloux, les débris de la route, le transport en rack, etc. ne sont pas couverts par cette garantie limitée.
- Les dommages au boîtier de pédalier Pressfit causés par un service, des matériaux ou des pièces inappropriés ne sont pas couverts par la garantie limitée Rocky Mountain.

#### Détail de ce qui n'est pas couvert par la garantie :

1. L'usure normale des pneus, chambres à air, freins, câbles de transmission, plaquettes de frein, roulements, etc., n'est pas couverte par la présente garantie. Votre détaillant Rocky Mountain autorisé vous informera de la nature de ces éléments d'entretien normal.
2. Les dommages consécutifs ou tout dommage causé par un accident (chute), une mauvaise utilisation ou un abus.
3. Un assemblage incorrect ou un manque d'entretien approprié; le sablage, le ponçage, le meulage, le brossage métallique, le limage, le soudage, le brasage, le perçage de trous, l'anodisation, la peinture ou le chromage ne sont pas couverts par notre garantie et peuvent annuler la garantie des autres composants.
4. Vous prenez de grands risques personnels et rendez la garantie nulle, comme indiqué dans le tableau de garantie, lorsque vous roulez sur des terrains extrêmes tels que décrits dans des vidéos de vélo de montagne (c'est-à-dire rouler sur des parcours de style « trial », monter sur des rampes, faire des cascades, rouler sur pistes de BMX, rouler en ville en bas et sur les talus, ou rouler sur d'autres terrains similaires). Il est important de noter que les composants ayant pliés, les cadres, les fourches, les guidons, les tiges de selle, les pédales, les manivelles et les jantes sont des signes d'accidents ou d'abus.
5. La main d'œuvre pour le remplacement ou le changement de pièces n'est pas couvert sous la présente garantie.
6. Rocky Mountain se réserve le droit de réparer ou de remplacer, à sa discrétion, toute pièce considérée comme couverte sous garantie. Veuillez noter que Rocky Mountain fera tout son possible pour assurer, mais ne peut garantir, une correspondance de couleur avec le composant d'origine.

#### EXCLUSIONS ET LIMITE DES DOMMAGES

LA GARANTIE DE ROCKY MOUNTAIN EST LIMITÉE À LA RÉPARATION OU AU REMPLACEMENT DES PRODUITS ET N'ACCORDE AUCUNE GARANTIE EXPLICITE OU IMPLICITE, LÉGALE OU CONVENTIONNELLE ET DÉCLINE TOUTE GARANTIE IMPLICITE DE QUALITÉ MARCHANDE ET D'ADAPTATION À DES USAGES PARTICULIERS ET ROCKY MOUNTAIN NE SERA EN AUCUN CAS RESPONSABLE POUR LES DOMMAGES DIRECTS OU INDIRECTS, SPÉCIAUX, ACCESSOIRES OU CONSÉCUTIFS MÊME LORSQUE ROCKY MOUNTAIN A ÉTÉ AVISÉ DE TELS DOMMAGES, ET LA RESPONSABILITÉ DE ROCKY MOUNTAIN SERA LIMITÉE À 50,00\$.

## DECLARATION DE CONFORMITÉ

Nous déclarons que les plateformes équipées de systèmes Powerplay™ sont conformes aux standards harmonisés pertinents de l'Union Européenne.

Rocky Mountain Instinct Powerplay SL™

Pour une liste complète des modèles, visitez [www.bikes.com](http://www.bikes.com)

Les produits décrits ci-dessus remplissent les requis des directives suivantes :

- Directive Machine 2006/42/EC
- Directive CEM 2014/30/EU
- Directive RoHS 2011/65/EU

Les produits ont été conçus et validés pour rencontrer les requis des normes suivantes :

- EN15194:2017 : Cycles à assistance électrique – Bicyclettes EPAC
- ISO4210-2:2015 : Exigences de sécurité pour les bicyclettes
- IEC/EN 62133-2:2017 : Accumulateurs alcalins et autres accumulateurs à électrolyte non acide – Exigences de sécurité pour les accumulateurs portables étanches, et pour les batteries qui en sont constituées, destinés à l'utilisation dans des applications portables – Partie 1 : Système au lithium
- EN50601-1L2016 : Batteries d'accumulateurs au lithium pour applications liées aux véhicules électriques légers – Partie 1 : exigences générales de sécurité et méthodes d'essai.

Je, Pierre-Luc Lapointe, Directeur R&D – Propulsion, suis désigné pour préparer la documentation technique en tant que représentant du manufacturier Rocky Mountain, Division d'Industries RAD inc.



**Pierre-Luc Lapointe, ing.**  
**R&D Director – Propulsion**  
**9095 25th Avenue, St-George, Quebec, Canada**

**Authorized European representative:**



**Carsten Bresser**  
**Managing Director, Bikeaction GmbH**  
**Weiskircher Str. 102, Rodgau, Germany**

### **Fabricant et Importateur UE**

Rocky Mountain  
Division of Industries RAD inc.  
9095, 25th Avenue  
Saint-Georges, Qc,  
Canada, G6A 1A1

### **Représentant autorisé en Europe**

Bikeaction GmbH  
Weiskircher Str. 102  
63110 Rodgau  
Germany

### **Suisse**

CHRIS Sports AG  
Wittenwilerstrasse 12,  
8355 Aadorf  
Switzerland

### **Norvège**

Vertical Playground AS  
Ola Setroms Veg 17  
7340 Oppdal  
Norway

**(EU) 2023/1542 ARTICLE 10 PART A OF ANNEX IV**

Model Name	Rated capacity and capacity fade		Power and power fade *This value is for reference only.				Internal resistance and internal resistance increase *This value is for reference only.		The expected life-time of the battery under the reference conditions for which is has been designed
	Rated capacity (Ah)	Capacity fade (%)	Power (W)		Power fade (%)		Internal resistance ( $\Omega$ )	Internal resistance increase (%)	Under the cycles (times)
			Power capability		Power capability				
			at 80%	at 20%	at 80%	at 20%			
1972002	14.3	>25	680	581	93	92	>0.143	195	1000
1972011	8.8	>50	676	581	96	95	>0.133	109	500
1974005	4.75	>25	383	328	91	89	>0.330	199	1000
1975006	9.5	>25	731	626	91	90	>0.162	196	1000

## SCHNELLSTART

### Connect the Jumbotron

In order to comply with shipping regulations, the power source must be disconnected in transit. Locate and connect the main power (battery) source to the motor.

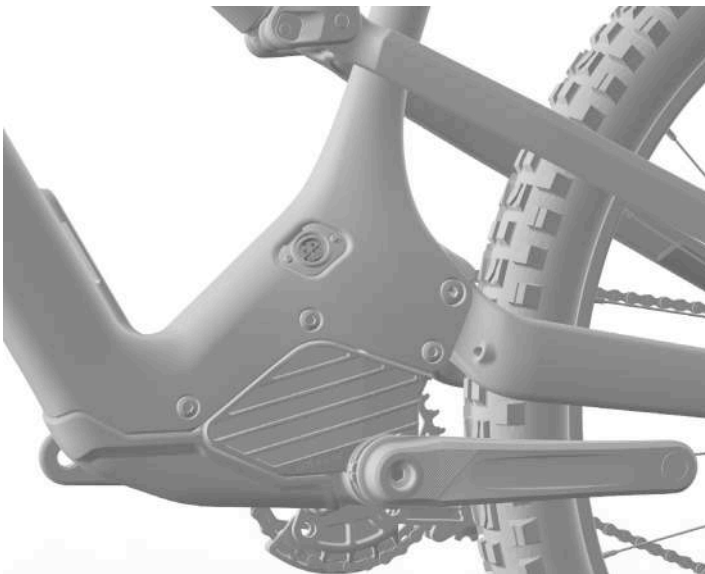

## SCHNELLSTART

### Laden Sie die Batterie auf

Der Akku muss mit einer Ladung von ca. 50% ausgeliefert werden. Bitte laden Sie Ihr Fahrrad vor dem ersten Gebrauch auf 100% auf. BEACHTEN SIE DIE AUSRICHTUNG DES STECKERS. Eine fehlerhafte Ausrichtung des Steckers kann zu dauerhaften Schäden führen.



## SCHNELLSTART

### Schalten Sie das Fahrrad ein

Halten Sie die Einschalttaste am Jumbotron 2 Sekunden lang gedrückt, um das Fahrrad einzuschalten.



Einschalten /  
Ausschalten

### Ihr Fahrrad einrichten

Bei der ersten Aktivierung fordert das Fahrrad den Fahrer auf, seine Einstellungen zu initialisieren. Dieser Schritt kann übersprungen werden, und Sie können sofort damit fahren, indem Sie ⚡. Sie können das Hauptmenü jederzeit wieder aufrufen, indem Sie die Taste ⚡.

### Tasten an Fernbedienung & Jumbotron



Befestigungsschraube

HALTEN  
Einschalten  
KLICKEN  
Durch die  
Unterstützung  
blättern  
HALTEN  
Ausschalten

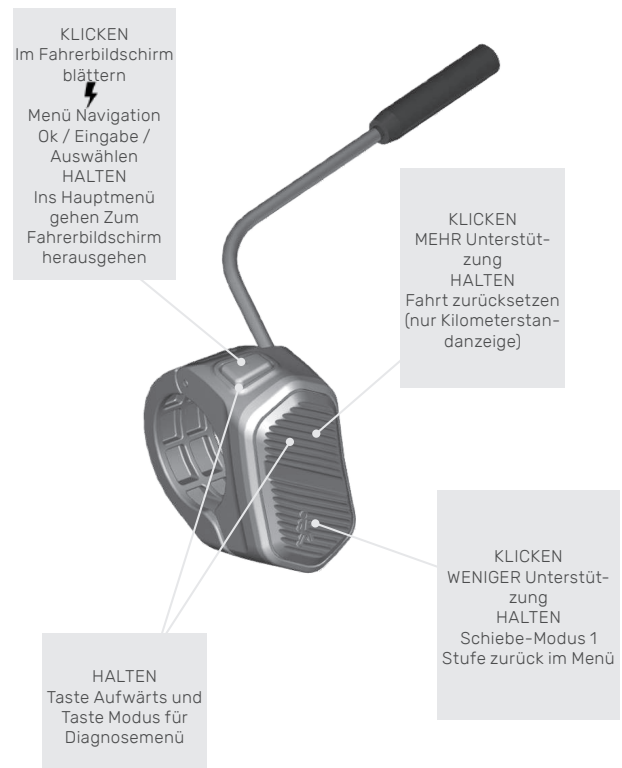

KLICKEN  
Im Fahrerbildschirm  
blättern  
⚡  
Menü Navigation  
Ok / Eingabe /  
Auswählen  
HALTEN  
Ins Hauptmenü  
gehen Zum  
Fahrerbildschirm  
herausgehen



KLICKEN  
MEHR Unterstüt-  
zung  
HALTEN  
Fahrt zurücksetzen  
(nur Kilometerstan-  
danzeige)

KLICKEN  
WENIGER Unterstüt-  
zung  
HALTEN  
Schiebe-Modus 1  
Stufe zurück im Menü



HALTEN  
Taste Aufwärts und  
Taste Modus für  
Diagnosemenü

## SCHNELLSTART



### Zugriff auf das Menü

Du kannst jederzeit ins Hauptmenü gelangen, indem du  gedrückt hältst. Zum Verlassen wählst du das Symbol ZURÜCK oder hältst  gedrückt.

### Zugang zur Diagnose

Du kannst jederzeit in das Diagnosemenü gelangen, indem du  und die Schaltfläche MEHR Unterstützung gleichzeitig gedrückt hältst. Zum Verlassen wählst du das Symbol ZURÜCK oder hältst  gedrückt.

### Navigation durch das Menü

Mit den Tasten MEHR Unterstützung und WENIGER Unterstützung der Fernbedienung kannst du durch die jeweiligen Menüs navigieren; bestätige Eingaben mit der Taste . Zum Verlassen wählst du das Symbol ZURÜCK oder hältst  gedrückt.

### Innerhalb von 100 km kalibrieren

Das Dynam S4 Lite Antriebssystem verwendet die Kettenspannung, um den Kraftaufwand des Fahrers zu messen. Da sich ein neues Antriebssystem erst einläuft, wird grundsätzlich empfohlen, das System nach ca. 75 km zu kalibrieren. Halte  gedrückt, um in das Hauptmenü zu gelangen, wähle Kalibrierung aus, und folge den Anweisungen.

## WARNUNG!

### KINDERMODUS

Dieses Elektrofahrrad ist mit einem Leistungs- und Geschwindigkeitsbegrenzer sowie einer Kindersicherung ausgestattet. Weitere Informationen zum Aktivieren und Anpassen dieser Einstellungen finden Sie im Abschnitt „DAS BIKE FAHREN“ in diesem Handbuch.

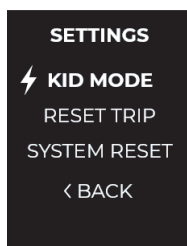

### Lies das Handbuch

Das Wichtigste zum Schluss: Lies das restliche Handbuch oder schlage online nach unter [support.bikes.com](http://support.bikes.com).

## **EINLEITUNG**

Dein Instinct, elektrisiert. Das Instinct Powerplay™ SL ist ein Kraftpaket im leichten Gewand. Angetrieben von unserem brandneuen Dynamie S4 Lite Antriebssystem, haben wir ein Bike entwickelt, das sich wie ein normales Trailbike fährt, aber die Kraft hat, weiter zu gehen als je zuvor. Die Geometrie und die Federkinematik des Rahmens, der auf unserem Mid-High-Pivot-Federsystem basiert, wurden komplett überarbeitet, um das Fahrgefühl weiter zu verbessern und eine Vielzahl von Rahmeneinstellungen zu ermöglichen.

Dieses Handbuch enthält wichtige Sicherheits-, Wartungs- und Benutzerinformationen. Bitte lesen Sie es vor der ersten Fahrt mit Ihrem neuen Rocky Mountain Instinct Powerplay™ SL sorgfältig durch und machen Sie sich mit ihm vertraut. Dieses Handbuch gilt nur für die von Ihnen gewählte Plattform und sollte in Verbindung mit der Rocky Mountain-Bedienungsanleitung verwendet werden, die Ihrem Fahrrad ebenfalls beiliegt. Bitte lesen Sie das Benutzerhandbuch vor Ihrer ersten Fahrt. Sollten Sie kein Exemplar der Bedienungsanleitung besitzen, können Sie diese bei Ihrem autorisierten Rocky Mountain-Händler oder online auf der Produktseite Ihres Fahrradmodells erhalten.

## **VERHALTENSREGELN**

### **Fahrer**

Nimm immer Rücksicht auf andere Trailbenutzer. Besondere Vorsicht gilt in der Nähe von Haustieren wie zum Beispiel Hunden und Pferden. Lass anderen Trailbenutzern in allen Situationen bergauf und bergab immer den Vortritt.

Die Instinct Powerplay SL™ -Modelle sind für das Fahren auf Trails in zugelassenen Gebieten vorgesehen. Das anvisierte Einsatzgebiet sind Fahrten in schwierigerem Terrain, das moderate Sprünge und technische Features beinhaltet. Diese Modelle sind nicht für extreme Fahrten vorgesehen, die extreme Sprünge oder steile Abfahrten in rauem Terrain mit Geschwindigkeiten über 40 km/h, oder eine Mischung davon, beinhalten. Auch Hardcore-Dirt Jumping, Freeriding, Downhill sowie Trails und Terrain vom Typ North Shore gehören nicht zum Einsatzgebiet. Diese Modelle sind nicht für große Drop-Offs, Sprünge oder Starts von Holzbauten oder Features, die harte Landungen oder harte Hindernisse beinhalten, geeignet.

### **Trail**

Benutze dein Powerplay™ Bike nur auf Trails, auf denen die Benutzung motorisierter Fahrzeuge gestattet ist. Befolge alle örtlichen Gesetze und Vorschriften. Wie auch alle anderen Trailbenutzer sollten alle Radfahrer darauf achten, Beschädigungen des Trails oder der Umwelt zu vermeiden. Vermeide Rutschen und Driften, und verändere die Trails nicht.

### **Öffentliche Straßen**

Bitte informiere dich vor der Fahrt mit deinem Rocky Mountain Instinct Powerplay SL über alle geltenden nationalen und regionalen Gesetze und Vorschriften. Das Fahren mit deinem Powerplay™ Bike auf öffentlichen Straßen, Radwegen oder Trails ist gegebenenfalls eingeschränkt. In manchen Fällen gelten auch Helm- und Beleuchtungsvorschriften, Altersbeschränkungen sowie Führerschein- oder Versicherungsvorschriften. Rocky Mountain gibt weder jetzt noch zukünftig Versprechen, Zusicherungen oder Garantien in Bezug auf die Nutzung deines Powerplay™ Fahrrads ab. Da Gesetze und Vorschriften für Elektrofahrräder von Land zu Land bzw. von Bundesland zu Bundesland unterschiedlich sind und sich ständig ändern, informiere dich bitte über den jeweils aktuellen Stand. Auch bei deinem Rocky Mountain Vertragshändler kannst du regelmäßig die neuesten Informationen einholen.

### **Sichtbarkeit und Sicherheit**

Bevor Sie mit Ihrem Rocky Mountain Powerplay-Fahrrad fahren, stellen Sie bitte sicher, dass alle in Ihrem Powerplay-Fahrrad enthaltenen Sicht- und Sicherheitsausrüstungen installiert sind, um die Einhaltung der gesetzlichen Anforderungen und Vorschriften in Ihrem Land, Bundesstaat oder Ihrer Provinz sicherzustellen.

Wenn Ihren Rocky Mountain Powerplay-Fahrrädern (Frankreich, Großbritannien, Australien und Neuseeland) eine Klingel beiliegt, muss diese vor der Verwendung zwingend an Ihrem Powerplay-Fahrrad angebracht werden.

## WARNUNGEN

### **Kraft**

Ihr Powerplay™-Fahrrad verfügt über eine kräftige Pedalunterstützung, sobald Druck auf die Pedale ausgeübt wird. Machen Sie sich mit den Fahr- und Pedalunterstützungseigenschaften Ihres Fahrrades in einer sicheren flachen Umgebung vertraut, bevor Sie es im Gelände benutzen.

### **Sofort-Startt**

Ihr Powerplay™-Fahrrad verfügt über die "Sofort-Start"-Technologie, welche eine ausgeklügelte Drehmoment-Sensorschaltung verwendet, um weiche, sofortige, sich natürlich anfühlende Kraft zu liefern. Diese Schaltung ist sehr empfindlich. Deshalb ist Vorsicht geboten, um sicherzustellen, dass das Rad nicht unerwartet oder unkontrolliert aus dem Stand beschleunigt.

### **Vorsicht auf Trails**

Ihr Powerplay™-Fahrrad beschleunigt schneller und verhält sich anders als traditionelle, nicht-unterstützte Fahrräder. Seien Sie vorsichtig auf Trails und seien Sie sich der einzigartigen Handling- und Beschleunigungseigenschaften Ihres Fahrrades bewusst.

### **Vorsicht!**

Fassen Sie die Antriebseinheit nicht an und verwenden Sie auch kein Werkzeug. Wartung und Reparatur der Antriebseinheit sollte nur von einem autorisierten Rocky Mountain Servicecenter durchgeführt werden.



### **Keine Veränderungen vornehmen**

Ändern Sie nichts an der Powerplay™-Antriebseinheit oder an direkt damit verbundenen Teilen. Wartung und Reparatur der Antriebseinheit sollte nur von einem autorisierten Rocky Mountain Servicecenter durchgeführt werden. Jeder Versuch, die Powerplay™-Antriebseinheit zu verändern, kann zu schweren Verletzungen oder dem Tod führen und macht die Garantie des Fahrrades sofort ungültig.

## WARNUNGEN

Bringe keinen Kindersitz, Anhänger oder ähnliche Zubehörteile an einem Verbundstoff- oder Carbonfaserteil bzw. -komponente an, weder direkt noch indirekt. Bringe zum Beispiel kein Dreieck an eine Hinterachse an, wenn das hintere Rahmendreieck aus Verbundstoff oder Carbonfaser besteht. Genauso solltest du keinen Anhänger an eine Sattelstütze aus Verbundstoff oder Carbon und keinen Kindersitz an eine Gabel aus Verbundstoff oder Carbon anbringen. In beiden Fällen können möglicherweise ungewöhnliche Kräfte auf deinen Fahrradrahmen oder eine Komponente einwirken, die zu Beschädigung und zum Totalausfall führen kann, was wiederum das Risiko für schwere oder tödliche Verletzungen in sich birgt. Wenn du zuvor ein Zubehörteil an einem Verbundstoff- oder Carbonfaserteil angebracht hattest, solltest du nicht mehr fahren und erst eine gründliche Inspektion bei einem Rocky Mountain Vertragshändler durchführen lassen. Bitte informiere dich über alle rechtlichen Vorschriften und Regelungen in deinem Land bzw. Bundesland, bevor du Kinder auf deinem Rad mitnimmst. Es gibt möglicherweise Beschränkungen bezüglich des Fahrens mit bestimmtem bzw. jeglichem Zubehör an deinem Fahrrad. Dies gilt insbesondere für elektrische Fahrräder und Fahrräder mit Tretunterstützung.

### WARNUNG 1

Wie alle mechanischen Bauteile sind auch elektromotorisch unterstützte Räder (EPAC) Verschleiß und hohen Belastungen ausgesetzt. Verschleiß und Ermüdungsbelastungen können sich unterschiedlich auf verschiedene Materialien und Bauteile auswirken. Wenn die Lebensdauer eines Bauteils überschritten ist, kann es unvermittelt ausfallen und möglicherweise zu Verletzungen des Fahrers führen. Risse, Kratzer oder Farbveränderungen jeglicher Art in stark beanspruchten Bereichen deuten darauf hin, dass die Lebensdauer des Bauteils erreicht ist und es ausgetauscht werden sollte.

### WARNUNG 2

Bei Bauteilen aus Verbundwerkstoff sind durch Schläge verursachte Schäden für den Benutzer eventuell unsichtbar. Der Hersteller muss die Folgen von Schlagschäden erläutern und darauf hinweisen, dass Bauteile aus Verbundwerkstoffen im Falle eines Aufschlages entweder zur Überprüfung an den Hersteller zurückgeschickt oder zerstört und ersetzt werden sollten.

### WARNUNG 3

Setzen Sie das Fahrrad nicht über längere Zeit direkter Sonneneinstrahlung oder übermäßiger Hitze aus, z. B. in einem geparkten Auto oder in der Nähe einer Wärmequelle wie einem Heizkörper. Übermäßige Hitze kann die Materialeigenschaften von Komponenten und Bauteilen wie Batterien, Verbundwerkstoffteilen wie Lenkern, Kurbelarmen und anderen Elementen aus Verbundmaterialien sowie von verschiedenen Kunststoffteilen, die zur Integrität des gesamten Fahrrads beitragen, beeinträchtigen.

### WARNUNG 4

Die maximal zulässige Gesamtnutzlast (Fahrer plus Gepäck und das Leergewicht des EPAC) beträgt 130 kg für das Carbon Instinct Powerplay SL und 140 kg für die Leichtmetallversion.

### WARNUNG 5

Das Nichtbefolgen der Warnhinweise in diesem Abschnitt kann zu Beschädigungen an den Komponenten deines Fahrrads führen und hebt die Garantie auf. Aber noch wichtiger ist, dass es kann zu schweren oder tödlichen Verletzungen führen kann. Wenn dein Fahrrad Anzeichen von Schäden aufweist, benutze es nicht, sondern bringe es sofort zu einem Rocky Mountain Vertragshändler, um es überprüfen zu lassen.

### WARNUNG 6

Im Falle eines Sturzes oder bei unsachgemäßer Montage können der Lenker und die Lenkkontrollen beeinträchtigt sein und der Fahrer kann möglicherweise nicht mehr sicher lenken und bremsen.

### WARNUNG 7

Pumpe einen Reifen nie über das Maximum des niedrigeren der auf dem Reifen angegebenen Reifendruckwerte und dem maximalen Wert auf der Felge, auf dem der Reifen montiert ist, auf. Das Überschreiten des Maximaldrucks kann dazu führen, dass der Reifen von der Felge gerissen wird, was wiederum zu Schäden am Fahrrad und Verletzungen des Fahrers und umstehender Personen führen kann.

## LERNE DEIN BIKE KENNEN



### TECHNISCHE DETAILS

- Das Instinct Powerplay™ SL ist mit unserem neuen Dymate S4 Lite Antriebssystem ausgestattet. Mit einem komplett neuen Rahmendesign ist der Rahmen des Instinct Powerplay SL erheblich leichter und bietet im Vergleich zu seinem Vorgänger zusätzliche Einstellmöglichkeiten für ein optimales Fahrgefühl.
- Die neue Dymate S4 Lite Antriebseinheit lässt Sie mit einem Spitzendrehmoment von bis zu 65 Nm und einer Spitzenleistung von bis zu 550 Watt die Anstiege problemlos meistern. Bei einer Trittfrequenz von 80 U/min bietet der Motor ca. 500 Watt Leistung.
- Das Dymate S4 Lite System basiert auf unserem patentierten externen Drehmomentsensor, der die Spannung direkt an der Kette misst, um ein sofortiges und natürliches Ansprechverhalten des Motors zu ermöglichen, ohne Verzögerung beim Antritt oder Nachschieben. Ausgestattet mit unserem neuen, leichten und schlanken 480-Wh-Akku erreicht das neue Dymate S4 Lite-System über 90 % der Reichweite und Höhenmeter, die unser Dymate 4.0-System bietet (Tests im Modus Ludicrous, Boost +2).
- Das Dymate S4 Lite System ist mit dem Jumbotron-Display ausgestattet, das nahtlos in das Oberrohr integriert ist und alle wichtigen Daten und Informationen an einer bequemen, leicht zu erkennenden Stelle anzeigt. Die Fahrinformationsseiten können mit der Lenkerfernbedienung oder den Tasten auf dem Jumbotron gesteuert und angepasst werden.
- Der überarbeitete Mid-High Pivot Hinterbau zeichnet sich durch Sensibilität in Verbindung mit einem erhöhten Gegendruck über den gesamten Federweg aus, mit dem Ziel, ein sicheres Fahrgefühl in jedem Terrain zu schaffen und den Komfort auf kurzen und langen Fahrten zu verbessern.
- Das Instinct Powerplay™ SL ist in einer breiten Auswahl von Rahmen- und Laufradgrößen verfügbar. Der XS-Rahmen ist mit 27,5"-Vorder- und Hinterrädern ausgestattet. Die SM-, MD-, LG- und XL-Rahmen sind mit 29"-Vorder- und Hinterrädern ausgestattet. Diese Größen sind auch Mullet-kompatibel mit der Verwendung eines speziellen MX-Links.
- Das RIDE-4™-Einstellsystem ermöglicht dem Fahrer eine schnelle und einfache Feinabstimmung der Geometrie und Kinematik.
- Alle Rahmen sind mit Reach Adjustment Steuersätzen zur Anpassung des Reaches ausgestattet. Am Rahmen ist ein 0 mm / neutraler Steuersatz installiert. In der Kleinteilbox, die jedem Rahmenset und Komplettrad beiliegt, befinden sich zusätzliche Steuersatzschalen, um den Reach um +/- 5 mm anzupassen.
- Gedichtete Kugellager am Dämpferauge verbessern das Ansprechverhalten des Dämpfers (kompatibel mit Aftermarket-Dämpfern). Zusätzlich gedichtete Lagerabdeckungen verhindern das Eindringen von Schmutz in die Lager bei schlammigen Abfahrten oder an Waschstationen nach der Fahrt.
- Unser Smoothlink-Hinterbau verfügt über gängige, leicht zu wartende Lager in Verbindung mit einer langlebigen Anlenk Konstruktion.
- Die vollständig geschlossene Innenverlegung an Carbon- und Aluminiummodellen ermöglicht dank des Kabelführungskanals eine einfache Kabel- und Leitungsverlegung, auch bei Bremsanlagen im Moto-Style.
- Die Rahmen sind mit einem umfangreichen Kettenstrebenschutz versehen, der sowohl die Geräuschentwicklung als auch Beschädigungen verhindert.

## GEOMETRIE UND GRÖSSEN

Das Instinct Powerplay™ SL verfügt über ein größenspezifisches Rahmendesign mit vielen Details, die die Passform und Geometrie für jeden Fahrer verbessern.

### Laufradgröße

- Der XS-Rahmen ist mit 27,5"-Laufrädern vorne und hinten ausgestattet.
- Der XS-Rahmen ist nicht kompatibel mit 29"-Laufrädern oder MX-kompatibel.
- Die Modelle SM, MD, LG und XL sind mit 29-Zoll-Rädern vorne und hinten ausgestattet.
- SM, MD, LG und XL sind mit Mullet/MX kompatibel, wenn das Gestänge der Aufhängung ausgetauscht wird.

### Steuersatz mit Reach-Einstellung

Alle Rahmen sind mit Steuersätzen für eine Reach-Anpassung ausgerüstet. Ein 0 mm / neutraler Steuersatz ist im Auslieferungszustand am Rahmen montiert. In der Kleinteilebox, die jedem Rahmenset und Kompletttrrad beiliegt, befindet sich ein zusätzlicher Satz 5 mm-Lagerschalen, mit denen der Reach angepasst werden kann. Die Geometrietabellen beziehen sich immer auf die neutrale Einstellung, auf die je nach verwendeten Schalen einfach 5 mm zu den Maßen für Reach, Oberrohrlänge und Radstand addiert oder subtrahiert werden können. Montageanweisungen sind im Abschnitt zu den Rahmeneigenschaften zu finden.

Carbon-Steuersatz 0 mm



Carbon-Steuersatz 5 mm



Alloy Steuersatz 0 mm



Alloy Steuersatz 5 mm



### Rahmengrößen

Diese Tabelle dient nur als grober Anhaltspunkt. Faktoren, die die Auswahl der richtigen Fahrradgröße beeinflussen, sind die Proportionen des Fahrers, der Fahrstil und persönliche Vorlieben. Im Allgemeinen haben Fahrräder mit kürzerem Reach ein dynamischeres, lebendigeres Fahrgefühl. Das Fahrgefühl auf längeren Fahrrädern ist in der Regel stabiler und gedämpfter. Rocky Mountain empfiehlt daher, die Bikes immer bei einem Vertragshändler Probe zu fahren und professionell anpassen zu lassen.

CM	147.5	150	152.5	152.5	155	157.5	160	162.5	165	167.5	170	172.5	175	177.5	180	183	185.5	188	190.5	193	195.5	198
FT-IN	4'7"	4'8"	4'9"	5'0"	5'1"	5'2"	5'3"	5'4"	5'5"	5'6"	5'7"	5'8"	5'9"	5'10"	5'11"	6'	6'1"	6'2"	6'3"	6'4"	6'5"	6'6"
	XS				SM				MD				LG				XL					
XS	[Red bar]																					
SM	[Red bar]																					
MD	[Red bar]																					
LG	[Red bar]																					
XL	[Red bar]																					

## GEOMETRIE UND DIMENSIONIERUNG

### RIDE-4-Einstellung

Das RIDE-4™ Einstellungssystem ermöglicht es Fahrern, ihre Geometrie mit einem einzigen 5-mm-Inbusschlüssel schnell fein abzustimmen. Vier Konfigurationen sind dank eines Paares von Drehchips möglich. Wie sich die einzelnen Positionen auf die Geometrie auswirken, entnehmen Sie bitte der Geometrietabelle. Anleitungen zur Einstellung finden Sie im Abschnitt Rahmenmerkmale.

**READY FOR ANY TRAIL**

Das RIDE-4™-Einstellsystem ermöglicht die schnelle Feinabstimmung von Geometrie und Federung mit einem einzigen 5-mm-Inbusschlüssel.

STEILER KOPF-ROHR-WINKELE  
WENIGER PROGRESSIVE AUFHÄNGUNG

SLACKER WINKEL DES STEUERROHRS  
PROGRESSIVERE FEDERUNG

**Position 1**

SLACK

Das niedrigere Tretlager und die progressive Federung erhöhen die Stabilität bei höheren Geschwindigkeiten. Empfohlen für aggressiveres Trailfahren

**Position 3**

NEUTRAL

Diese Position bietet eine ausgewogene Mischung aus Geometrie und Federungsleistung, um eine Vielzahl von Strecken zu bewältigen.

**Position 4**

STEEP

Das höhere Tretlager und die lineare Federung ermöglichen eine bessere Pedalfreiheit, eine unterstützende Anfangsfederung und eine für das Klettern besser geeignete Position auf dem Rad.

## GEOMETRIE UND DIMENSIONIERUNG

RAHMENGRÖSSE		XS	SM	MD	LG	XL
LAUFRADGRÖSSE		27.5			29	
Steuerrohrwinkel (Grad)		63.5	63.5	63.5	63.5	63.5
Sitzrohrwinkel (Grad)		76.4	77.0	76.5	76.5	76.5
Sitzrohrlänge (mm)		355.0	365.0	410.0	440.0	470.0
Oberrohrlänge (mm)		542.0	567.0	599.0	627.0	659.0
Steuerrohrlänge (mm)		105.0	105.0	110.0	125.0	135.0
Kettenstrebenlänge (mm)	Position 1 - Slack	433.0	442.0	442.0	452.0	452.0
Tretlagerabsenkung (mm)		24.2	38.8	38.8	38.7	38.8
Schritthöhe (mm)		775.0	785.0	809.0	808.0	807.0
Radstand (mm)		1157.0	1205.0	1232.0	1274.0	1308.0
Reach (mm)		399.0	425.0	450.0	475.0	505.0
Stack (mm)		590.0	618.0	622.0	636.0	645.0
<hr/>						
Steuerrohrwinkel (Grad)		63.7	63.7	63.7	63.7	63.7
Sitzrohrwinkel (Grad)		76.6	77.2	76.7	76.7	76.7
Sitzrohrlänge (mm)		355.0	365.0	410.0	440.0	470.0
Oberrohrlänge (mm)		541.0	567.0	599.0	627.0	659.0
Steuerrohrlänge (mm)		105.0	105.0	110.0	125.0	135.0
Kettenstrebenlänge (mm)	Position 2	430.0	440.0	440.0	450.0	450.0
Tretlagerabsenkung (mm)		17.0	32.0	32.0	32.0	32.0
Schritthöhe (mm)		780.0	790.0	813.0	813.0	813.0
Radstand (mm)		1154.0	1203.0	1230.0	1272.0	1306.0
Reach (mm)		405.0	430.0	455.0	480.0	510.0
Stack (mm)		586.0	614.0	618.0	632.0	641.0

## GEOMETRIE UND DIMENSIONIERUNG

RAHMENGRÖSSE		XS	SM	MD	LG	XL
LAUFRADGRÖSSE		27.5			29	
Steuerrohrwinkel (Grad)		64.0	64.0	64.0	64.0	64.0
Sitzrohrwinkel (Grad)		77.0	77.5	77.0	77.0	77.0
Sitzrohrlänge (mm)		355.0	365.0	410.0	440.0	470.0
Oberrohrlänge (mm)		540.0	566.0	598.0	626.0	658.0
Steuerrohrlänge (mm)		105.0	105.0	110.0	125.0	135.0
Kettenstrebenlänge (mm)	Position 3 - Neutral	430.0	440.0	440.0	450.0	450.0
Tretlagerabsenkung (mm)		17.0	32.0	32.0	32.0	32.0
Schritthöhe (mm)		780.0	790.0	813.0	813.0	813.0
Radstand (mm)		1154.0	1203.0	1230.0	1272.0	1306.0
Reach (mm)		405.0	430.0	455.0	480.0	510.0
Stack (mm)		586.0	614.0	618.0	632.0	641.0
<hr/>						
Steuerrohrwinkel (Grad)		64.2	64.2	64.2	64.2	64.2
Sitzrohrwinkel (Grad)		77.2	77.7	77.2	77.2	77.2
Sitzrohrlänge (mm)		355.0	365.0	410.0	440.0	470.0
Oberrohrlänge (mm)		540.0	566.0	597.0	625.0	657.0
Steuerrohrlänge (mm)		105.0	105.0	110.0	125.0	135.0
Kettenstrebenlänge (mm)	Position 3 - Neutral	429.0	439.0	439.0	449.0	449.0
Tretlagerabsenkung (mm)		14.1	29.2	29.1	29.1	29.0
Schritthöhe (mm)		782.0	792.0	816.0	815.0	815.0
Radstand (mm)		1153.0	1202.0	1229.0	1271.0	1305.0
Reach (mm)		407.0	432.0	457.0	482.0	512.0
Stack (mm)		585.0	612.0	617.0	630.0	639.0

## PASSUNG VON VARIO-SATTELSTÜTZEN

Vario-Sattelstützen spielen eine wichtige Rolle, wenn es um die Passform und den Komfort von Fahrrädern geht. Nachfolgend findest du die wichtigsten Abmessungen, die dir bei der Konfiguration der OEM-Sattelstütze helfen, sowie einige der möglichen Optionen für Sekundärmarkt-Sattelstützen. Die Tabelle zeigt die Passung der Sattelstütze in voll ausgefahrenem Zustand. Damit kannst du die niedrigste bzw. höchste Position deiner Sattelstütze für die korrekte Höhe in einer sitzenden Tretposition ermitteln. Die Tabelle hilft auch, die richtige Größe der Sattelstütze zu bestimmen, wenn die OEM-Stütze nicht wie gewünscht passt. Bitte beachte, dass die angegebenen Maße von der Mitte des Tretlagers bis zur Oberseite des OEM-Sattels ermittelt wurden. Die Länge der Kurbelgarnitur kann die Sitzposition beeinflussen und sollte ebenfalls berücksichtigt werden, wenn diese Komponente geändert wird.

So verwendest du diese Tabelle

1. Miss deine aktuelle Sattelhöhe von der Mitte des Tretlagers bis zur Oberkante des Sattels direkt über der Sattelstütze.
2. Wähle das gewünschte Sattelstützenmodell und den gewünschten Hub sowie den Rahmen.
3. Vergewissere dich, dass deine Messung im Bereich zwischen der in der Tabelle angegebenen Mindest- und Höchsteinschubtiefe liegt.

Beispiel: Bei meinem derzeitigen Fahrrad habe ich 795 mm gemessen. Wenn ich mich für ein OneUp V3 mit 210 mm Hub an einem LG Carbon Rahmen entscheide, kann ich sehen, dass diese Kombination aus Federweg und Rahmengröße passt, da die möglichen Mindest- und Höchstmaße 725 mm bis 855 mm betragen

POST MODEL	POST TRAVEL	FRAME SIZE	CARBON					ALLOY				
			XS	SM	MD	LG	XL	XS	SM	MD	LG	XL
		Seat Tube Length	355	365	410	440	470	355	365	410	440	470
		Minimum Insertion	100	100	100	100	100	100	100	100	100	100
		Maximum Insertion	220	230	275	305	335	220	230	275	305	335
<b>X Fusion Manic</b>	125	Minimum saddle height	541	547	592	622	652	541	547	592	622	652
	125	Maximum saddle height	623	633	678	708	738	623	633	678	708	738
	150	Minimum saddle height	605	605	617	647	677	605	605	617	647	677
	150	Maximum saddle height	687	697	742	772	802	687	697	742	772	802
	170	Minimum saddle height	649	649	649	667	697	649	649	649	667	697
	170	Maximum saddle height	701	711	756	786	816	701	711	756	786	816
	190	Minimum saddle height	702	702	702	702	717	702	702	702	702	717
	190	Maximum saddle height	734	744	789	819	849	734	744	789	819	849
<b>2025 Fox Transfer</b>	120	Minimum saddle height	556	566	611	641	671	556	566	611	641	671
	120	Maximum saddle height	646	656	701	731	761	646	656	701	731	761
	150	Minimum saddle height	619	619	642	672	702	619	619	642	672	702
	150	Maximum saddle height	711	721	766	796	826	711	721	766	796	826
	180	Minimum saddle height	684	684	684	701	731	684	684	684	701	731
	180	Maximum saddle height	776	786	831	861	891	776	786	831	861	891
	210	Minimum saddle height	749	749	749	749	761	749	749	749	749	761
	210	Maximum saddle height	841	851	896	926	956	841	851	896	926	956
	240	Minimum saddle height	819	819	819	819	819	819	819	819	819	819
	240	Maximum saddle height	911	921	966	996	1026	911	921	966	996	1026

POST MODEL	POST TRAVEL	FRAME SIZE	CARBON					ALLOY				
			XS	SM	MD	LG	XL	XS	SM	MD	LG	XL
<b>2020-2024 Race Face Turbine R Fox Transfer</b>	125	Minimum saddle height	572	573	618	648	678	572	573	618	648	678
	125	Maximum saddle height	664	674	719	749	779	664	674	719	749	779
	150	Minimum saddle height	626	626	643	673	703	626	626	643	673	703
	150	Maximum saddle height	718	728	773	803	833	718	728	773	803	833
	175	Minimum saddle height	683	683	683	698	728	683	683	683	698	728
	175	Minimum saddle height	775	785	830	860	890	775	785	830	860	890
	200	Minimum saddle height	739	739	739	739	754	739	739	739	739	754
	200	Maximum saddle height	781	791	836	866	896	781	791	836	866	896
<b>OneUp V3 Dropper</b> *Travel can be reduced by up to 20mm, in 10 mm increments.	120	Seat Tube Length	550	560	605	635	665	550	560	605	635	665
	120	Minimum Insertion	650	660	705	735	765	650	660	705	735	765
	150	Maximum Insertion	595	595	635	665	695	595	595	635	665	695
	150	Minimum saddle height	700	710	755	785	815	700	710	755	785	815
	180	Maximum saddle height	660	660	665	695	725	660	660	665	695	725
	180	Minimum saddle height	750	760	805	835	865	750	760	805	835	865
	210	Maximum saddle height	725	725	725	725	755	725	725	725	725	755
	210	Minimum saddle height	800	810	855	885	915	800	810	855	885	915
	240	Maximum saddle height	790	790	790	790	790	790	790	790	790	790
240	Minimum saddle height	850	860	905	935	965	850	860	905	935	965	
<b>Reverb AXS</b> *Min post insertion is 80mm, however frame requires 100mm	125	Minimum saddle height	593	600	645	675	705	593	600	645	675	705
	125	Maximum saddle height	710	720	765	795	825	710	720	765	795	825
	150	Minimum saddle height	643	643	670	700	730	643	643	670	700	730
	150	Maximum saddle height	760	770	815	845	875	760	770	815	845	875
	170	Minimum saddle height	683	683	690	720	750	683	683	690	720	750
	170	Maximum saddle height	800	810	855	885	915	800	810	855	885	915

## SPEZIFIKATIONEN UND ABMESSUNGEN

### Steuersatz mit Reach-Einstellung

Alle Rahmen sind mit Steuersätzen für eine Reach-Feineinstellung ausgerüstet. Ein 0 mm / neutraler Steuersatz ist am Rahmen vormontiert. In der Kleinteilebox, die jedem Rahmenset und Komplettrrad beiliegt, befindet sich ein zusätzlicher Satz 5 mm-Lagerschalen, mit denen der Reach angepasst werden kann.

Für den Carbon Instinct Powerplay™ SL-Rahmen werden ovale Steuersatzschalen im Drop-in-Stil verwendet. Der Aus- und Einbau der Lagerschalen in den Rahmen erfordert keine Werkzeuge, da sich die Schalen durch ihre zentrierende ovale Form automatisch ausrichten. Zur Minimierung von bewegungsbedingter Geräuschbildung sind die Lagerschalen außen mit integrierten O-Ringen versehen. Die Steuersätze für die Carbon-Rahmen werden von FSA hergestellt und tragen die Modell-Nr. 85-1. Da Standard-FSA-Montageteile wie Lager und Laufringe verwendet werden, gestaltet sich der Austausch von Verschleißteilen einfach.

Der Alloy Instinct Powerplay™ SL-Rahmen hingegen verwendet Oversized-Steuersatzschalen zum Einpressen. Hierfür wird spezielles Werkzeug benötigt. Da diese Lagerschalen und das Steuerrohr nicht zentriert sind, ist bei der Montage besondere Sorgfalt geboten. Die Lagerschalen sind außen markiert, um ihre Ausrichtung am Rahmen zu erleichtern. Um die korrekte Ausrichtung sicherzustellen, kann ein langes Lineal entlang dieser Markierung über die Länge des Oberrohrs (obere Lagerschale) oder Unterrohrs (untere Lagerschale) gelegt werden. Die Steuersätze für die Alloy-Rahmen werden ebenfalls von FSA hergestellt und tragen die Modell-Nr. HS-RM-01. Auch hier erleichtert die Verwendung von Standard-FSA-Montageteilen wie Lager und Laufringe den Austausch von Verschleißteilen.

### Instinct Powerplay SL Carbon Steuersatz

ANZ.	ARTIKEL	TEILENUMMER	BESCHREIBUNG
N/A	Steuersatz	14100078000013	FSA Teil Nummer   Nr.85-10mm Gekröpfter Steuersatz, komplett
N/A.	Steuersatz	1194001	RMB Teil Nummer   Nr.85-10mm Gekröpfter Steuersatz, komplett
1	Steuersatz Cup Set	141-0079000011	FSA Teil Nummer   Nr.85-15mm Nur gekröpfte Becher
1	Steuersatz Cup Set	1194002	RMB Teil Nummer   Nr.85-15mm Gekröpfte Becher inkl. O-Ring
1	Gummi-O-Ring	160-7042	FSA Obere Kappe Innerer Gummi-O-Ring
1	Obere Kappe	161-4430	FSA 5,3mm Obere Kappe inkl. Gummidichtung
1	Split Race	160-7626	FSA 1 1/8" Steuersatz-Kompressionsring
1	Geteiltes Rennen	160-6465	FSA Rostfrei ACB 1 1/8" 36°x45° Lager
1	Geteiltes Rennen	160-67400E	FSA Rostfrei ACB 1.5" 36°x45° Lager
1	Kronenrennen	160-5536	FSA 1.5" Kronenrennen

### Instinct Powerplay SL Aluminium Steuersatz

ANZ.	ARTIKEL	TEILENUMMER	BESCHREIBUNG
N/A	Steuersatz	1194003	RMB ZS56 66 0mm Gekröpfter Steuersatz, komplett
N/A.	Steuersatz Cup Set	1194004	RMB Obere ZS56   5mm Versetzter Bechersatz
1	Gummi-O-Ring	160-7042	Obere Kappe Innerer Gummi-O-Ring
1	Obere Kappe	161-4430	FSA 5,3mm Obere Kappe inkl. Gummidichtung
1	Split Race	160-7626	FSA 1 1/8" Steuersatz-Kompressionsring
1	Geteiltes Rennen	160-6465	FSA Rostfrei ACB 1 1/8" 36°x45° Lager
1	Geteiltes Rennen	160-67400E	FSA Rostfrei ACB 1.5" 36°x45° Lager
1	Kronenrennen	160-5536	FSA 1.5" Kronenrennen

## DÄMPFER-LAGERBUCHSEN UND HARDWARE

Ihr Rahmen ist am hinteren Dämpferauge mit Eyeletbearings ausgestattet, die für ein besseres Ansprechverhalten bei kleinen Unebenheiten sorgen. Diese Lager sitzen in Schalen, die einen sehr festen Presssitz im Dämpferauge haben. Wenn Sie Ihren Dämpfer warten lassen, empfehlen wir Ihnen dringend, die Eyeletbearings zu entfernen, da die Fahrwerkswerkstätten nicht garantieren können, dass diese wieder mit zurückgeschickt werden.

Die vordere Dämpferbefestigung verwendet einen Standardsatz, der vom Dämpferhersteller bereitgestellt wird. In der nachstehenden Tabelle finden Sie technische Informationen zu allen Dämpferbauteilen, Diagramme als Referenz und Anweisungen zum Entfernen des Eyeletbearings.



**Montage** Instinct Powerplay SL Hinterraddämpfer Lagerauge  
**Abmessungen** 40 x 8mm (Breite x Hardware-Durchmesser)

ARTIKEL NUMMER	ANZ.	ARTIKEL	TEILENUMMER	BESCHREIBUNG
N/A.	1	SATZ STOSSDÄMPFERLAGER- ÖSEN	1811007	8 x 40mm Stoßdämpferlager-Ösen-Kit
6	2	Lager	1801010	ENDURO 688 LLU MAX 16X8X5
17	2	Lagerschale	1800031	LAGERÖSE FÜR 16X8X5 BRG
71	1	Ärmel	1807028	ZENTRIERHÜLSE FÜR DAS LAGERAUGE
18	2	Lager-Distanzstück	1800032	ABSTANDHALTER FÜR ÖSENLAGER, T:6.3, FÜR 40 MM GLIEDERBREITE

**Montage** Instinct Powerplay SL Vorwärtsdämpfer Hardware  
**Abmessungen** 25 x 8mm (Shock Pin Breite x Hardware-Durchmesser)

ARTIKEL NUMMER	ANZ.	ARTIKEL	TEILENUMMER	BESCHREIBUNG
N/A	1	Fox Komplettpaket	803-03-328	FOX Befestigungselemente - 9 Stück AL 8mm x 25mm/0.984
N/A	1	RockShox Komplet Kit	11.4118.091.816	RockShox, Dämpfer-Hardware, 8 X 25.0mm

Profi-Tipp: Das Fox Complete Kit ist mit den Rock Shox Dämpferösen kompatibel. Entfernen Sie die Teflonbuchse von der Rock Shox Öse, bevor Sie das Fox Kit installieren.

## DÄMPFER LAGERBUCHSE UND HARDWARE

### Ausbau des Lagerauges

Befolge zum Ausbau des Systems diese Schritte:

- Verwende den Rocky Mountain Lagerbuchsen-Werkzeugsatz (Teile-Nr. 1810031)
- Bringe das obere Kopfteil an einer Seite der Lagerbuchse an.
- Bringe als nächstes einen der Lagerschalenabzieher über der Lagerschale mit dem angebrachten oberen Kopfteil an.
- Drehe die M8 Schraube bis zum Anschlag gegen das obere Kopfteil.
- Bringe den anderen Lagerschalenabzieher über der anderen Lagerschale an.
- Ziehe die M8 Schraube vollständig fest, bis sie gegen die andere Seite zu drücken beginnt. Sie berührt das Innere des oberen Kopfteils.
- Drehe weiter, bis eine der Schalen vollständig herausgedrückt ist.
- Führe danach den Durchschlag durch die Dämpferaufnahme und setze ihn fest gegen die noch in die Dämpferaufnahme eingepresste Lagerschale.
- Schlage mit einem Hammer vorsichtig, aber fest auf den Durchschlag, bis die Lagerschale vollständig von der Dämpferaufnahme entfernt ist.

### Wenn du keinen Rocky Mountain Lagerbuchsen-Werkzeugsatz hast, verwende ein Innenlagerabzieher:

- Verwende einen Innenlagerabzieher (8 mm Aufsatz) für den Ausbau beider Lager.
- Entferne die mittlere Hülse.
- Verwende den Innenlagerabzieher (10 mm Aufsatz) für den Ausbau der leeren Schalen.

*HINWEIS: Der Innendurchmesser der Schalen beträgt 11 mm, das bedeutet, dass der 12 mm Aufsatz nicht passt (wende also keine Gewalt an). Verwende den 10 mm Aufsatz.*

Verwende für den Einbau neuer Schalen eine Lagerpresse oder einen Schraubstock mit weichen Backen. Stelle sicher, dass du auf den Außenrand der Schalen drückst, und vergiss die mittlere Distanzhülse zwischen den Schalen nicht.

## FAHRWERKSEINSTELLUNGEN

Bevor Sie Ihre Dämpfereinstellungen ändern, sollten Sie sich über die verschiedenen Einstellmöglichkeiten informieren.

### Einstellung der Feder

Je nach Dämpfermodell müssen Sie möglicherweise die Dämpferfederrate oder den Luftdruck anpassen, um den empfohlenen Negativfederweg für das Instinct Powerplay™ SL zu erreichen. In der nachstehenden Tabelle finden Sie Empfehlungen für Federhärten und Luftdrücke.

### Zugstufe

Die Einstellung der Zugstufe regelt, wie schnell die Federung nach einem Stoß wieder vollständig ausfedert. Eine zu starke Einstellung führt dazu, dass Gabel oder Federbein zu langsam zurückkehren und sich bei wiederholten Stößen tief im Federweg einsetzen, was sich rau anfühlt. Bei einer zu geringen Einstellung hingegen kann die Federung zu schnell zurückschnellen, was Traktionsverlust und mangelnde Kontrolle zur Folge haben kann.

**Low Speed Rebound (LSR)** Diese Einstellung betrifft niedrige Geschwindigkeiten der Gabel oder des Dämpfers und beeinflusst die Zugstufe im ersten Teil des Federwegs.

**High Speed Rebound (HSR)** Diese Einstellung betrifft hohe Geschwindigkeiten der Gabel oder des Dämpfers und beeinflusst die Zugstufe im zweiten Teil des Federwegs. Es ist wichtig, diese Einstellungen entsprechend Ihren persönlichen Vorlieben und den spezifischen Geländebedingungen anzupassen, um ein optimales Fahrerlebnis zu gewährleisten.

## SUSPENSIONSANORDNUNG

### Komprimierung

Die Druckstufe kontrolliert, wie schnell sich Ihre Federung bei einem Schlag durch den Federweg bewegt. Eine zu starke Einstellung der Druckstufe lässt die Gabel oder das Federbein zu langsam arbeiten, wodurch die Kraft des Aufpralls stark vom Reifen und Ihrem Körper absorbiert wird. Bei zu geringer Einstellung bewegen sich Gabel oder Federbein zu schnell durch den Federweg, was das Fahrrad träge und unempfindlich macht.

**Low-Speed Compression (LSC)** Die LSC betrifft die niedrigen Einfedergeschwindigkeiten der Gabel oder des Dämpfers und steuert die Gewichtsverlagerung des Fahrers, das Pumpen durch Wellen, G-outs und andere langsame Schläge. Eine Überdosierung der LSC führt zu einem härteren Fahrgefühl, während zu wenig LSC ein zu weiches und schwammiges Fahrgefühl verursacht. Die Wirkung der LSC erstreckt sich über den gesamten Federweg.

**High Speed Compression (HSC)** HSC bezieht sich auf hohe Geschwindigkeiten der Gabel oder des Dämpfers und reguliert die Fähigkeit, große und schnelle Stöße wie Felsen und Bodenwellen zu absorbieren. Eine übermäßige Einstellung der HSC führt auf schnellen, rauen Trails mit vielen großen Unebenheiten zu einem härteren Fahrgefühl. Zu wenig HSC resultiert in unzureichender Unterstützung des Fahrwerks und kann dazu führen, dass der Federweg zu schnell freigegeben wird.

### Hydraulischer Bodenauslauf

Hydraulic Bottom Out (HBO) bezieht sich auf den hydraulischen Widerstand gegen das Durchschlagen des Dämpfers, den einige Dämpfer in Verbindung mit einem externen Piggyback-Reservoir bieten können. Dies ist besonders wirksam in den letzten 20 % des Federwegs und kommt bei großen Schlägen zum Einsatz, um zu verhindern, dass das Fahrrad durchschlägt.

In den folgenden Tabellen finden Sie alle OEM-Dämpferkonfigurationen für das Instinct Powerplay SL. Aufgrund der Vielzahl an Dämpfern, die mit dem Instinct Powerplay SL kompatibel sind, können wir keine Setup-Anleitungen für Modelle außerhalb der OEM-Spezifikationen zur Verfügung stellen.

### Tipps und Tricks zur Federung

Wenn Sie Ihre Federung einstellen, ist es ratsam, Ihre Einstellungen aufzuschreiben, damit Sie später darauf zurückgreifen können. Noch besser ist es, eine Online-Tabelle auf Ihrem Telefon zu verwenden.

Der Ausbau des Dämpfers am Instinct Powerplay™ SL mit Smoothlink-Federung ist unkompliziert, erfordert jedoch möglicherweise einige Tipps und Tricks. Nachfolgend finden Sie eine Schritt-für-Schritt-Anleitung für den Ausbau. Für den Einbau folgen Sie einfach den Anweisungen in umgekehrter Reihenfolge. Beachten Sie unbedingt die im SOP-Abschnitt dieser Anleitung angegebenen Drehmomentwerte.

1. Schalten Sie auf das kleinste Ritzel der Kassette herunter und sperren Sie den Schaltwerkskäfig, falls möglich.
2. Entfernen Sie das Hinterrad.
3. Stellen Sie sicher, dass die Bereiche des Rahmens zwischen dem Sitzrohr und dem Lenker frei von Verschmutzungen sind. Reinigen Sie diese gegebenenfalls gründlich.
4. Entfernen Sie die Schraube der vorderen Dämpferaufnahme. Halten Sie dabei den Hinterbau fest und senken Sie ihn vorsichtig ab, bis die Sitzstrebenbrücke das Sitzrohr berührt.
5. Entfernen Sie die Schraube der hinteren Dämpferaufnahme. Wenn erforderlich, können Sie die Ride4-Chips auf beiden Seiten entfernen.
6. Entnehmen Sie den Dämpfer. Stellen Sie sicher, dass die Spacer des Eyeletbearings locker sind, und halten Sie eine Hand unter dem Bereich des Eyeletbearings, um diese aufzufangen.

## SUSPENSIONSANORDNUNG

### 2025 INSTINCT POWERPLAY SL FOX FLOAT X AIR SHOCK

SCHOCK ABMESSUNGEN	SM - MD - LG - XL = 230 X 57.5MM	DÄMPFEREINSTELLUNGEN	0.4 SPACER, CS40, RL40, LMF, REZI B40			
ANMERKUNGEN	ERHÖHEN SIE DEN DRUCK UM 10PSI   0,7BAR FÜR SM *ZÄHLEN SIE DIE KLICKS AB GESCHLOSSEN: 0 KLICKS = GESCHLOSSEN*					
FAHRERGEWICHT	DRUCK	SHOCK SAG	LSR	HBO	LSC	HSC
100lbs   45kg	120psi   8.3bar		10		9 - Open	
110lbs   50kg	130psi   9bar		10		9	
120lbs   55kg	140psi   9.7bar		10 - 9		8 - 9	
130lbs   59kg	150psi   10.3bar		9		8	
140lbs   64kg	160psi   11bar		9 - 8		7 - 8	
150lbs   68kg	170psi   11.7bar		8		7	
160lbs   73kg	180psi   12.4bar	SM - XL 17 - 20mm	8 - 7	Nicht verfügbar	6 - 7	Nicht verfügbar
170lbs   77kg	190psi   13.1bar		7		6	
180lbs   82kg	200psi   13.8bar		7 - 6		5 - 6	
190lbs   86kg	210psi   14.5bar		6		5	
200lbs   91kg	220psi   15.2bar		6 - 5		4 - 5	
210lbs   95kg	230psi   15.9bar		5		4	
220lbs   100kg	240psi   16.5bar		5 - 4		3 - 4	
230lbs   105kg	250psi   17.2bar		4		3	
240lbs   109kg	260psi   17.9bar		4 - 3		2 - 3	
250lbs   114kg	270psi   18.6bar		3		2	

### 2025 INSTINCT POWERPLAY SL FOX FLOAT AIR SHOCK

SCHOCK ABMESSUNGEN	XS = 210 X 52.5MM	DÄMPFEREINSTELLUNGEN	0.2 SPACER, CL, RM, CMF			
ANMERKUNGEN	ERHÖHEN SIE DEN DRUCK UM 10PSI   0,7BAR FÜR SM *ZÄHLEN SIE DIE KLICKS AB GESCHLOSSEN: 0 KLICKS = GESCHLOSSEN*					
FAHRERGEWICHT	DRUCK	SHOCK SAG	LSR	HBO	LSC	HSC
100lbs   45kg	120psi   8.3bar		10			
110lbs   50kg	130psi   9bar		10			
120lbs   55kg	140psi   9.7bar		10 - 9			
130lbs   59kg	150psi   10.3bar		9			
140lbs   64kg	160psi   11bar		9 - 8			
150lbs   68kg	170psi   11.7bar		8			
160lbs   73kg	180psi   12.4bar	XS 15 - 18mm	8 - 7	Nicht verfügbar	Start Open Anpassen an Präferenz	Nicht verfügbar
170lbs   77kg	190psi   13.1bar		7			
180lbs   82kg	200psi   13.8bar		7 - 6			
190lbs   86kg	210psi   14.5bar		6			
200lbs   91kg	220psi   15.2bar		6 - 5			
210lbs   95kg	230psi   15.9bar		5			
220lbs   100kg	240psi   16.5bar		5 - 4			
230lbs   105kg	250psi   17.2bar		4			
240lbs   109kg	260psi   17.9bar		4 - 3			
250lbs   114kg	270psi   18.6bar		3			

## SUSPENSIONSANORDNUNG

### 2025 INSTINCT POWERPLAY SL ROCKSHOX SUPER DELUXE AIR SHOCK

SCHOCK ABMESSUNGEN	SM - MD - LG - XL = 230 X 57.5MM   BC EDITION = 230 X 60MM	DÄMPFERE-INSTELLUNGEN	MD - LG - XL = 0 NEG 1 POS TOKEN - REBOUND 25 - COMP 30 - LOCKOUT 4 SM = 0 NEG 0 POS TOKENS - REBOUND 25 - COMP 26 - LOCKOUT 4			
ANMERKUNGEN	ERHÖHEN SIE DEN DRUCK UM 10PSI   0,7BAR FÜR SM *ZÄHLEN SIE DIE KLICKS AB GESCHLOSSEN: 0 KLICKS = GESCHLOSSEN*					
FAHRERGEWICHT	DRUCK	SHOCK SAG	LSR	HBO	LSC	HSC
100lbs   45kg	120psi   8.3bar		11 - 12			
110lbs   50kg	130psi   9bar		10 - 11			
120lbs   55kg	140psi   9.7bar		9 - 11	Starte bei neutraler Einstellung (3. Position)	Starte bei neutraler Einstellung (3. Position)	Starte bei neutraler Einstellung (3. Position)
130lbs   59kg	150psi   10.3bar		8 - 9	Nimm die Einstellung klickweise vor, bis das gewünschte Bottom-Out-Gefühl erreicht ist. Das optionale Hydraulic Bottom Out drosselt den Öldurchfluss in den letzten 20 % des Federwegs und sorgt für eine weiche hydraulische Dämpfung, die ein hartes Durchschlagen verhindert.	Nimm die Einstellung klickweise vor, um die gewünschte Unterstützung bei Bewegungen mit niedriger Wellendrehzahl zu erzielen, z. B. beim Fahren über Bodenwellen mit Pump-Technik, beim Vorspannen für einen Sprung oder Drop oder für mehr Unterstützung bei Anstiegen.	Nimm die Einstellung klickweise vor, um die gewünschte Unterstützung bei Bewegungen mit hoher Wellendrehzahl zu erhalten, wie z. B. bei Hindernissen mit felsigem Terrain und bei großen Drops.
140lbs   64kg	160psi   11bar		8 - 10			
150lbs   68kg	170psi   11.7bar	SM - XL	6 - 7			
160lbs   73kg	180psi   12.4bar	17 - 20mm	6 - 7			
170lbs   77kg	190psi   13.1bar	BC Edition	5 - 6			
180lbs   82kg	200psi   13.8bar	18 - 21mm	5 - 6			
190lbs   86kg	210psi   14.5bar		4 - 5			
200lbs   91kg	220psi   15.2bar		4 - 5			
210lbs   95kg	230psi   15.9bar		3 - 4			
220lbs   100kg	240psi   16.5bar		2 - 3			
230lbs   105kg	250psi   17.2bar		2 - 3			
240lbs   109kg	260psi   17.9bar		1 - 2			
250lbs   114kg	270psi   18.6bar		1 - 2			

### 2025 INSTINCT POWERPLAY SL ROCKSHOX DELUXE AIR SHOCK

SCHOCK ABMESSUNGEN	XS = 210 X 52.5MM   BC EDITION = 210 X 55MM	DÄMPFERE-INSTELLUNGEN	MD - LG - XL = 0 NEG 1 POS TOKENS, PROGRESSIVE REB-LOW COMP TUNE, 320LB LOCKOUT SM = 0 NEG 0 POS TOKENS, PROGRESSIVE REB-L1 COMP TUNE, 320LB LOCKOUT XS = 0 NEG 0 POS TOKENS, PROGRESSIVE REB-LOW COMP TUNE, 320LB THRESHOLD			
ANMERKUNGEN	ERHÖHEN SIE DEN DRUCK UM 10PSI   0,7BAR FÜR SM *ZÄHLEN SIE DIE KLICKS AB GESCHLOSSEN: 0 KLICKS = GESCHLOSSEN*					
FAHRERGEWICHT	DRUCK	SHOCK SAG	LSR	HBO	LSC	HSC
100lbs   45kg	120psi   8.3bar		10			
110lbs   50kg	130psi   9bar		10			
120lbs   55kg	140psi   9.7bar		10 - 9			
130lbs   59kg	150psi   10.3bar		9			
140lbs   64kg	160psi   11bar		9 - 8			
150lbs   68kg	170psi   11.7bar		8			
160lbs   73kg	180psi   12.4bar	XS	8 - 7			
170lbs   77kg	190psi   13.1bar	15 - 18mm	7			
180lbs   82kg	200psi   13.8bar	BC Edition	7 - 6	Nicht verfügbar	Start Offen Anpassen an Präferenz	Nicht verfügbar
190lbs   86kg	210psi   14.5bar	16 - 19mm	6			
200lbs   91kg	220psi   15.2bar		6 - 5			
210lbs   95kg	230psi   15.9bar		5			
220lbs   100kg	240psi   16.5bar		5 - 4			
230lbs   105kg	250psi   17.2bar		4			
240lbs   109kg	260psi   17.9bar		4 - 3			
250lbs   114kg	270psi   18.6bar		3			

## WICHTIGE ABMESSUNGEN

ITEM NUMBER	CATEGORY	ITEM	DIMENSION	PART NUMBER	DESCRIPTION
1	Headset	Carbon Frame Headset	FSA No.85-1 0mm Offset		FSA No.85-1 0mm Offset Headset, complete. See Headset chart for information
		Carbon Frame Headset Cup Set	FSA No.85-1 5mm Offset		FSA No.85-1 5mm Offset cups only. See Headset chart for information
		Alloy Frame Headset	FSA ZS56 66 0mm Offset		FSA RMB ZS56 66 0mm Offset Headset, complete. See Headset chart for information
		Alloy Frame Headset Cup Set	FSA ZS56 66 5mm Offset		FSA RMB ZS56 66 5mm Offset cups only. See Headset chart for information
2	Fork	Fork Travel	150mm		Compatible with 160mm
		Fork Offset	27.5"   XS = 37mm		
		Maximum Axle to Crown Height	29"   SM - MD - LG - XL = 42 - 44mm		
			27.5"   XS = 557.6mm		
3	Shock	Shock Size	XS = 210 x 52.5mm		XS frames are compatible with 210 x 55mm shocks. This increases rear wheel travel to 150mm.
			SM - MD - LG - XL = 230 x 57.5mm		SM - MD - LG - XL frames are compatible with 230 x 60mm shocks. This increases rear wheel travel to 150mm.
		Shock Tune	See Description		Refer to Shock Setup chart for tune information
		Forward Shock Hardware	25 x 8mm		See Shock Hardware chart for information
		Rear Shock Hardware	40 x 8mm	1811007	Requires custom bearing eyelet hardware. See Shock Hardware chart for information
		Approved Shock Fitment	See Description		All Fox rear shock models. All RockShox rear shock models. All Cane Creek Shock models. Other rear shock manufacturers' models may fit, but will require fitment on frame to check clearances at full extension and compression.
4	Seatpost	Seat Tube Inner Diameter	30.9mm		
		Seat Tube Outer Diameter	34.9mm		
		Seat Tube Minimum Insertion	100mm		
			XS = 220mm		
			SM = 230mm		
		Seat Tube Machined Ream Depth (Identical on Carbon & Alloy)	MD = 275mm LG = 305mm XL = 335mm		For seatpost fitment information, refer to the seatpost fitment section in this manual

ITEM NUMBER	CATEGORY	ITEM	DIMENSION	PART NUMBER	DESCRIPTION
		Chainring Size Range	34T		Instinct Powerplay SL bikes are only compatible with 34 tooth chainrings.
		OEM Chainring Size   Chain Length	27.5"   XS = 34T   122L 29"   SM - MD = 34T   122L 29"   LG - XL = 34T   124L		
5	Crankset	Lower Chain Guide Kit	See Description	1995026	Bashguard bracket with idler, 2025 Instinct Powerplay SL
		Chain Guide	See Description	1995013	Motor Output Chainguide, 2025 Instinct Powerplay SL
		Bashguard	2-Bolt Custom Mount		2-Bolt mounting pattern to fit Instinct Powerplay SL bashguards only
		Bottom Bracket	PressFit BB92		Remove the bottom bracket's inner plastic sleeve to install.
		Chainline	51mm		Compatible Rocky Mountain Ratchet Spider assembly only.
7	Brake	Maximum Rotor Diameter	223mm		
		Maximum Rotor Thickness	2.0mm		
8	Wheel	Wheel Size	XS = 27.5" SM - MD - LG - XL = 29"		XS is only compatible with 27.5" wheels. MX compatible on all sizes with dedicated link (Link C   1815087)
		Maximum Tire Width	2.5"   63mm		
9	Rear Hub	Hub Spacing	12 x 148mm		
		Rear Axle	12 x 1.0 x 173mm	3222000	Diameter 12mm x Thread Pitch 1.0mm x Length 173mm
		Complete Hanger Kit	See Description	1812002	Includes Hanger, nut, and washer. For individual parts see exploded diagram
		UDH   Transmission	See Description		Frame is UDH and Eagle Transmission compatible.

## DREHMOMENTANGABEN FÜR BEFESTIGUNGSELEMENTE

Das korrekte Anzugsdrehmoment von Schraubverbindungen ist entscheidend für Ihre Sicherheit. Ziehen Sie die Schrauben immer mit dem richtigen Drehmoment an. Im Falle von Widersprüchen zwischen den Anweisungen in diesem Handbuch und den Angaben eines Komponentenherstellers sollten Sie sich an Ihren Händler oder den Kundendienst des Herstellers wenden, um Klarheit zu erhalten. Zu fest angezogene Schrauben können sich dehnen und verformen. Zu locker angezogene Schrauben können sich bewegen und ermüden. Beide Fehler können zu einem plötzlichen Versagen der Schraube führen.

Verwenden Sie stets einen korrekt kalibrierten Drehmomentschlüssel, um kritische Befestigungselemente an Ihrem Fahrrad anzuziehen. Befolgen Sie genau die Anweisungen des Herstellers des Drehmomentschlüssels zur richtigen Einstellung und Verwendung, um präzise Ergebnisse zu erzielen.

# EXPLOSIONSZEICHNUNG

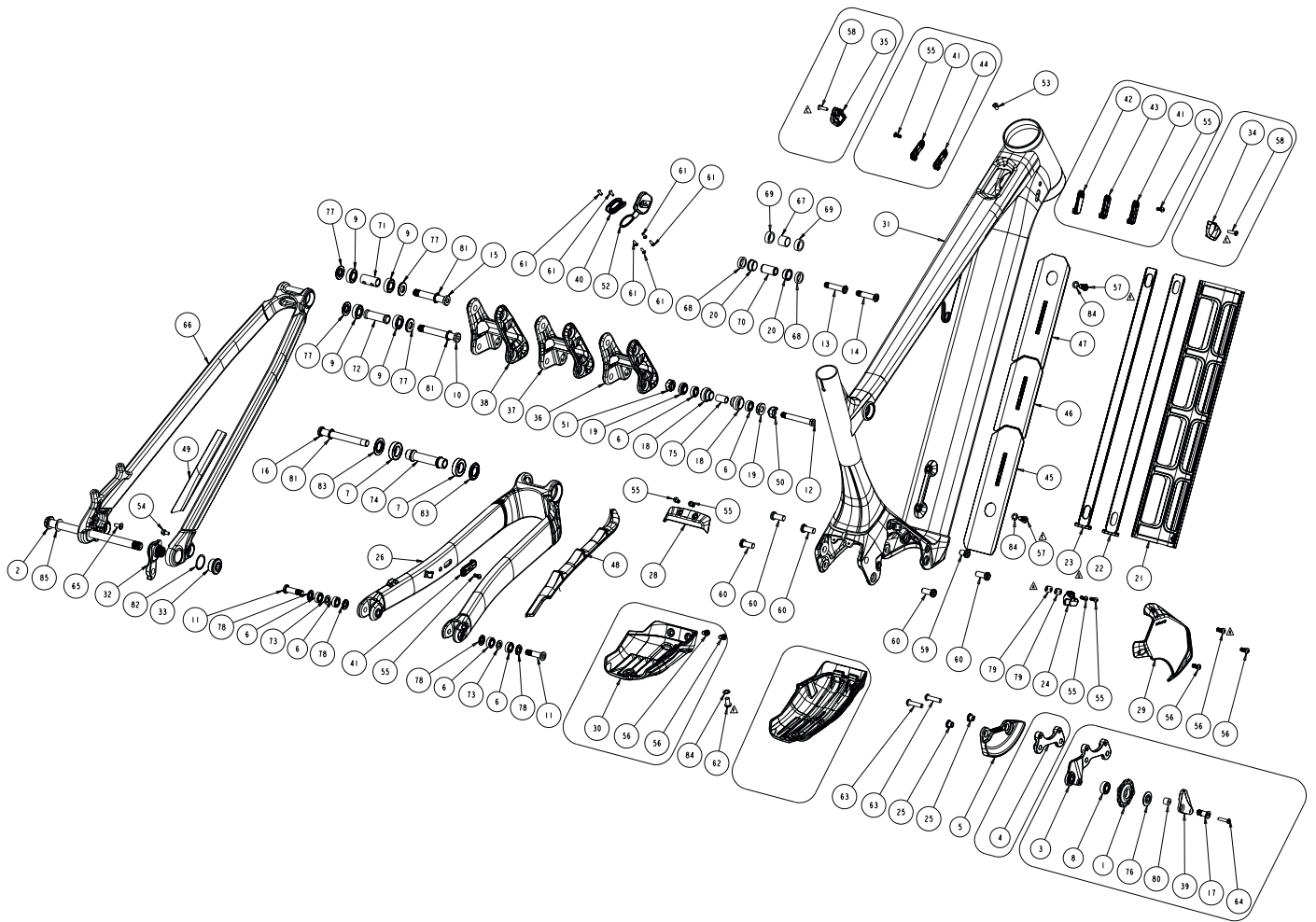

## LISTE DER KLEINTEILE-SÄTZE

<b>2025 INSTINCT POWERPLAY SL CARBON ALLOY</b>					
# LIST	P1	QTY	ITEM	PART NO.	SUPPLIER REVISION DESCRIPTION
37	1	LINK		<b>1815085</b> 1095002	<b>ZCA013</b> <b>2025 INSTINCT PP LINK 29"</b> MY25 INSTINCT POWERPLAY - LINK B
36	1	LINK		<b>1815086</b> 1095001	<b>ZCA013</b> <b>2025 INSTINCT PP LINK 27.5"</b> MY25 INSTINCT POWERPLAY - LINK A
38	1	LINK		<b>1815087</b> 1095003	<b>ZCA013</b> <b>2025 INSTINCT PP MULLET LINK</b> MY25 INSTINCT POWERPLAY - LINK C
32	1	HANGER		<b>1812002</b> 1092003	<b>PTW047</b> <b>2022 HANGER KIT 12 x1.0</b> MY22 REAR DER. HANGER, M12X1, UDH COMPATIBLE
33	1	HANGER NUT		1801008	PTW047 RMB UDH HANGER NUT, 7075_T6, HARD BLACK ANODIZED
82	1	WASHER		1801009	PTW047 WASHER, 20X24X0.5MM, 304 SS
16	1	BOLT		<b>1815088</b> 1805154	<b>PTW047</b> <b>2025 INSTINCT PP PIVOT BOLT KIT</b> BOLT, MAIN PIVOT, 10 MM OD, M10x1.25, 86 MM L, 6 MM HEX
10	1	BOLT		1801004	PTW047 LINK BOLT, LOWER, M10X1.0, L:70.5, 6MM HEX
15	1	BOLT		1804058	PTW047 UPPER LINK BOLT, M10x1.0, L:59.4
11	2	BOLT		1801007	PTW047 ALTITUDE DROPOUT BOLT, M8X1.0, L:30, 6MM HEX
71	1	SLEEVE		1800008	PTW047 TT BEARING SLEEVE, ID:10, OD:14, L:29
72	1	SLEEVE		1800010	PTW047 SS BEARING SLEEVE, ID:10, OD:14, L:41, NECKED
74	1	SLEEVE		1805156	PTW047 SLEEVE, MAIN PIVOT, 10MM ID, 52.5 MM L
73	2	SLEEVE		1800040	PTW047 DROPOUT BEARING SLEEVE, OD:14, ID:8, T:1.8, 6061 ALU
77	4	SPACER		1800009	PTW047 LINK BEARING SPACER, OD:22, ID:10, T:2.5
78	4	SPACER		1800039	PTW047 DO BEARING SPACER, OD:16, ID:8, T:1.75, 6061 ALU
81	3	WASHER		1800019	PTW047 WASHERID: 10.2, OD: 15.5, T:1
83	2	WASHER		1805155	PTW047 WASHER, MAIN PIVOT, 15MM ID, 27.5MM OD, 2.5MM T
11	2	BOLT		<b>1814055</b> 1801007	<b>PTW047</b> <b>DROPOUT PIVOT BOLT KIT</b> ALTITUDE DROPOUT BOLT, M8X1.0, L:30, 6MM HEX
6	6	BEARING		<b>1815089</b> 1801010	<b>ZCA013</b> <b>2025 INSTINCT PP PIVOT BEARING KIT</b> ENDURO 688 LLU MAX 16X8X5
9	4	BEARING		1807042	ENDURO 6900 2RS MAX 22X10X6
7	2	BEARING		1805159	ENDURO 6902 LLU MAX 28X15X7
12	1	BOLT		<b>1815090</b> 1802008	<b>PTW047</b> <b>2025 INST PP AL SHOCK BOLT KIT</b> RIDE 4 BOLT, M8 x 1, OD: 8 mm, L:56, 5 mm Hex
14	1	BOLT		1804057	SHOCK BOLT, M8X1.0, L:35, 5mm HEX
12	1	BOLT		<b>1815091</b> 1802008	<b>PTW047</b> <b>2025 INST PP CR SHOCK BOLT KIT</b> RIDE 4 BOLT, M8 x 1, OD: 8 mm, L:56, 5 mm Hex
13	1	BOLT		1803026	SHOCK BOLT, M8X1.0, L:36.5, 5mm hex
6	2	BEARING		<b>1811007</b> 1801010	<b>ZCA013</b> <b>SHOCK BEARING EYELET KIT 2021</b> ENDURO 688 LLU MAX 16X8X5
75	1	SLEEVE		1807028	PTW047 BEARING EYELET CENTRE SLEEVE
18	2	BRG CUP		1800031	PTW048 BEARING EYELET FOR 16X8X5 BRG
19	2	BRG SPACER		1800032	PTW049 EYELET BEARING SPACER, T:6.3, FOR 40 MM LINK WIDTH
2	1	AXLE, REAR		<b>1812007</b> 3222000	<b>PTW047</b> <b>AXLE KIT BOOST 12X1.0</b> REAR AXLE 12X1.0 L:173MM, HARD BLACK ANODIZE
85	1	WASHER		3227006	PTW047 WASHER, 12x19x0.5MM, 304 SS
34	1	HT PORT COVER		<b>1815092</b> 1803012	<b>PTW047</b> <b>**** 2025 INST PP HT PANEL KIT (NEW)</b> 2023 SLAYER CARBON HT PORT COVER, RIGHT
35	1	HT PORT COVER		1803013	PTW047 2023 SLAYER CARBON HT PORT COVER, LEFT
58	2	SCREW		1805077-BK	PTW048 C'SUNK SOCKET SCREW, M4X16, STAINLESS STEEL, BLACK

## LISTE DER KLEINTEILE-SÄTZE

		<b>1815093</b>	<b>ZCA013</b>	<b>POWERPLAY ALLOY FRAME HT CABLE PORT KIT</b>
55	3 SCREW	1804060		M4X0.7, 10MM, 2.5 HEX, BUTTON HEAD, SS, BLACK
41	3 PORT COVER	1093011		ALLOY CABLE PORT COVER DOUBLE HOLE
42	1 PORT COVER	1093012		ALLOY CABLE PORT COVER BLANK
43	1 PORT COVER	1093013		ALLOY CABLE PORT COVER SINGLE 4mm HOLE
44	1 PORT COVER	1093014		ALLOY CABLE PORT COVER SINGLE 5mm HOLE
		<b>1815094</b>		<b>ALLOY POWERPLAY FRAME CS CABLE PORT KIT STD SIZE</b>
41	1 PORT COVER	1093011		ALLOY CABLE PORT COVER DOUBLE HOLE
55	1 SCREW	1804060		M4X0.7, 10MM, 2.5 HEX, BUTTON HEAD, SS, BLACK
		<b>1812010</b>	<b>PTW047</b>	<b>RIDE 4 THREADED CHIP KIT</b>
50	1 RIDE 4 CHIP	1802009	PTW047	RIDE 4 CHIP, NO THREAD.
51	1 RIDE 4 CHIP	1802010	PTW047	RIDE 4 CHIP, THREADED, M8 x 1.
		<b>1815095</b>	<b>ZCA013</b>	<b>2025 INSTINCT PP PROTECTION KIT XS/SM</b>
48	1 PROTECTOR	1705006		2025 INSTINCT POWERPLAY CHAINSTAY PROTECTOR
49	1 PROTECTOR	3702021		SEATSTAY PROTECTOR, TRIMMED
45	1 PROTECTOR	1705003		DOWNTUBE PROTECTOR - A - 2025 INSTINCT POWERPLAY
46	2 PROTECTOR	1705004		DOWNTUBE PROTECTOR - B - 2025 INSTINCT POWERPLAY
		<b>1815096</b>	<b>ZCA013</b>	<b>2025 INSTINCT PP PROTECTION KIT MD/LG/XL</b>
48	1 PROTECTOR	1705006		2025 INSTINCT POWERPLAY CHAINSTAY PROTECTOR
49	1 PROTECTOR	3702021		SEATSTAY PROTECTOR, TRIMMED
45	1 PROTECTOR	1705003		DOWNTUBE PROTECTOR - A - 2025 INSTINCT POWERPLAY
46	1 PROTECTOR	1705004		DOWNTUBE PROTECTOR - B - 2025 INSTINCT POWERPLAY
47	1 PROTECTOR	1705005		DOWNTUBE PROTECTOR - C - 2025 INSTINCT POWERPLAY
		<b>1815097</b>		<b>2025 INSTINCT PP BB COVER SM/MD/LG/XL</b>
27	1 COVER	1995005		BOTTOM BRACKET COVER, CO-MOLDED, 2025 IPP
62	1 SCREW	1805170		SCREW, BUTTON HEAD, 18-8 SS, RAW STAINLESS, M6X1.0, 12MM LENGTH
84	1 WASHER	1805172		WASHER, 6x10x0.5MM, 304 SS
		<b>1815098</b>		<b>2025 INSTINCT PP BB COVER XS</b>
30	1 COVER	1995018		FOR X-SMALL ONLY, BOTTOM BRACKET COVER, 2025 INSTINCT POWERPLAY
62	1 SCREW	1805170		SCREW, BUTTON HEAD, 18-8 SS, RAW STAINLESS, M6X1.0, 12MM LENGTH
84	1 WASHER	1805172		WASHER, 6x10x0.5MM, 304 SS
56	2 SCREW	1804063		LOW PROFILE SOCKET HEAD SCREW, M5X10, STAINLESS STEEL, BLACK
		<b>1815099</b>		<b>2025 INSTINCT PP MAIN PIVOT COVER</b>
28	1 COVER	1995016		MAIN PIVOT COVER, 2025 INSTINCT POWERPLAY
55	2 SCREW	1804060		M4X0.7, 10MM, 2.5 HEX, BUTTON HEAD, SS, BLACK
		<b>1815100</b>	<b>PTW047</b>	<b>UDH STOP SCREW KIT M4X8</b>
54	1 SCREW	1802012		UDH STOP SCREW M4X8
		<b>1814050</b>	<b>ZCA013</b>	<b>5M OFFSET HEAD SET CUPS KIT CR BIKES</b>
1	HEAD SET CUP	1194002	PUS105	FSA 5MM OFFSET OVAL CUPS W/ORING CR BIKES
		<b>1814051</b>	<b>ZCA013</b>	<b>5M OFFSET HEAD SET CUPS KIT AL BIKES</b>
1	HEAD SET CUP	1194004	PUS105	FSA 5MM OFFSET CUPS AL BIKES
		<b>1814052</b>	<b>ZCA013</b>	<b>OVAL OFFSET HEADSET KIT CR BIKES</b>
1	HEADSET	1194001	PUS105	FSA NO.85 1.5" OMM OFFSET OVAL CUPS STAINLESS
		<b>1814053</b>	<b>ZCA013</b>	<b>OFFSET HEADSET KIT AL BIKES</b>
1	HEADSET	1194003	PUS105	FSA ZS56   66 OMM OFFSET HS STAINLESS STEEL
		<b>1815101</b>		<b>2025 INSTINCT PP BASH GUARD KIT</b>
5	1 BASH GUARD PLATE	1995028		BASH GUARD PLATE - 2025 INSTINCT POWERPLAY
25	2 CHAINRING BOLT	1805173		CHAINRING BOLT, CUSTOM, M8 X 0.75, LENGTH 6MM

## LISTE DER KLEINTEILE-SÄTZE

		<b>1815102</b>		<b>2025 INSTINCT PP CHAIN GUIDE KIT W/BASH GUARD</b>
5	1 BASH GUARD PLATE	1995028		BASH GUARD PLATE - 2025 INSTINCT POWERPLAY
4	1 BASH GUARD BRACKET	1995027		BASH GUARD BRACKET, WITHOUT IDLER - 2025 INSTINCT POWERPLAY
63	2 SCREW	1805171		SCREW, BUTTON HEAD, 18-8 SS, BLACK, M6X1.0, 25MM LENGTH
25	2 CHAINRING BOLT	1805173		CHAINRING BOLT, CUSTOM, M8 X 0.75, LENGTH 6MM
		<b>1815103</b>		<b>2025 INSTINCT PP CHAIN GUIDE KIT W/ BASH GUARD &amp; IDLER</b>
3	1 BASH GUARD BRACKET	1995026		BASH GUARD BRACKET, WITH IDLER - 2025 INSTINCT POWERPLAY
17	1 BOLT, M8X18	1807126		BOLT M8 X 18MM CUSTOM. 6061 HARD BLACK ANO.
39	1 PLATE	1094020		REAPER POWERPLAY LOWER PULLEY PLATE
64	1 SCREW, M4X20	1809011		C'SUNK SOCKET SCREW, M4x20mm, STAINLESS STEEL 316
80	1 SPACER	3399006		LOWER CHAIN GUIDE SPACER
1	1 11T COG	1347012	REV B	11T COG, FOR 19mm BEARING
8	1 BEARING	1807036		ENDURO 698 LLU 19X8X6
76	1 SPACER	1347013		CHAINSTAY PULLEY GUIDE SPACER,
5	1 BASH GUARD PLATE	1995028		BASH GUARD PLATE - 2025 INSTINCT POWERPLAY
63	2 SCREW	1805171		SCREW, BUTTON HEAD, 18-8 SS, BLACK, M6X1.0, 25MM LENGTH
25	2 CHAINRING BOLT	1805173		CHAINRING BOLT, CUSTOM, M8 X 0.75, LENGTH 6MM
		<b>1998024</b>		<b>CHAIN STAY PULLEY KIT</b>
1	1 11T COG	1347012	REV B	11T COG, FOR 19mm BEARING
8	1 BEARING	1807036		ENDURO 698 LLU 19X8X6
76	1 SPACER	1347013		CHAINSTAY PULLEY GUIDE SPACER,
		<b>1815104</b>	<b>PTW047</b>	<b>2025 INSTINCT POWERPLAY SL UPPER CHAIN GUIDE KIT</b>
24	1 CHAIN GUIDE	1995013		MOTOR OUTPUT CHAIN GUIDE, 2025 INSTINCT POWERPLAY
55	2 SCREW	1804060		M4X0.7, 10MM, 2.5 HEX, BUTTON HEAD, SS, BLACK
79	2 SPACER	1805191		CHAINGUIDE SPACER, 0.5MM, 304 STAINLESS STEEL, 2025 IPP
		<b>1815105</b>	<b>PTW047</b>	<b>2025 INSTINCT POPWERPLAY BATTERY BOLT KIT</b>
57	2 SCREW	1804065		M6 X 14MM, LOW BUTTON HEAD SCREW, SS, BLACK COATED
84	1 WASHER	1805172		WASHER, 6x10x0.5MM, 304 SS
		<b>1815106</b>	<b>PTW047</b>	<b>2025 INSTINCT POWERPLAY CHARGE PORT KIT</b>
40	1 PLATE	1995015		CHARGE PORT PLATE, 2025 INSTINCT POWERPLAY
52	1 RUBBER CAP	1995014		CHARGE PORT RUBBER CAP, 2025 INSTINCT POWERPLAY
61	6 SCREW	1805160		SCREW, BUTTON HEAD, 18-8 SS, BLACK, M3X0.5, L:8MM
		<b>1815107</b>	<b>PTW047</b>	<b>2025 INSTINCT PP SL ALLOY CABLE FLUTE XS/SM</b>
21	1 CABLE GUIDE	1995006		DOWNTUBE CABLE GUIDE FLUTE - 2025 INSTINCT POWERPLAY
22	1 CABLE GUIDE	1995007		DOWNTUBE CABLE GUIDE WEDGE - 2025 INSTINCT POWERPLAY
		<b>1815114</b>	<b>PTW047</b>	<b>2025 INSTINCT PP SL ALLOY CABLE FLUTE MD/LG/XL</b>
21	1 CABLE GUIDE	1995006		DOWNTUBE CABLE GUIDE FLUTE - 2025 INSTINCT POWERPLAY
23	1 CABLE GUIDE	1995048		DOWNTUBE CABLE GUIDE WEDGE - SLIM - 2025 IPP
		<b>1815108</b>	<b>PTW047</b>	<b>2025 INSTINCT POWERPLAY SL DRIVE SIDE MOTOR COVER</b>
29	1 COVER	1995017		DS COVER, 2025 INSTINCT POWERPLAY
56	3 SCREW	1804063		LOW PROFILE SOCKET HEAD SCREW, M5X10, STAINLESS STEEL, BLACK
		<b>1815109</b>	<b>PTW047</b>	<b>2025 INSTINCT POWERPLAY SL MOTOR MOUNT BOLT KIT</b>
60	5 SCREW	1805158		MOTOR MOUNTING SCREW, M8x1.25, 18 MM L, 304 SS, BUTTON HEAD
59	1 SCREW	1805157		MOTOR MOUNTING SCREW, M8x1.25, 10 MM L, 304 SS, BUTTON HEAD

## TEILELISTE UND MONTAGEANLEITUNG

#	QTY	ITEM	PART NO.	DESCRIPTION	SUPPLIER	TORQUE(Nm)	INSTALLATION NOTES
1	1	11T COG	1347012	11T COG, FOR 19mm BEARING	OVERTOP		
2	1	AXLE, REAR	3222000	REAR AXLE 12X1.0 L:173MM, HARD BLACK ANODIZE	OVERTOP		10 Grease axle shaft and threads
3	1	BASH GUARD BRACKET	1995026	BASH GUARD BRACKET, WITH IDLER - 2025 INSTINCT POWERPLAY	SHING FONG		
4	1	BASH GUARD BRACKET	1995027	BASH GUARD BRACKET, WITHOUT IDLER - 2025 INSTINCT POWERPLAY	SHING FONG		
5	1	BASH GUARD PLATE	1995028	BASH GUARD PLATE - 2025 INSTINCT POWERPLAY	CREATE THINK		
6	6	BEARING	1801010	ENDURO 688 LLU MAX 16X8X5	ABI		Grease bearing race faces before installation
7	2	BEARING	1805159	ENDURO 6902 LLU MAX 28X15X7	ABI		Grease bearing race faces before installation
8	1	BEARING	1807036	ENDURO 698 LLU 19X8X6	ABI		Grease bearing race faces before installation
9	4	BEARING	1807042	ENDURO 6900 2RS MAX 22X10X6	ABI		Grease bearing race faces before installation
10	1	BOLT	1801004	LINK BOLT, LOWER, M10X1.0, L:70.5, 6MM HEX	OVERTOP		10 Grease axle shaft, Loctite 243 (blue) on threads
11	2	BOLT	1801007	ALTITUDE DROPOUT BOLT, M8X1.0, L:30, 6MM HEX	OVERTOP		10 Grease axle shaft, Loctite 243 (blue) on threads
12	1	BOLT	1802008	RIDE 4 BOLT, M8 x 1, OD: 8 mm, L:56, 5 mm Hex	OVERTOP		10 Grease axle shaft, Loctite 243 (blue) on threads
13	1	BOLT	1803026	SHOCK BOLT, M8X1.0, L:36.5, 5mm hex	OVERTOP		10 Grease axle shaft, Loctite 243 (blue) on threads
14	1	BOLT	1804057	SHOCK BOLT, M8X1.0, L:35, 5mm HEX	OVERTOP		10 Grease axle shaft, Loctite 243 (blue) on threads
15	1	BOLT	1804058	UPPER LINK BOLT, M10x1.0, L:59.4	OVERTOP		10 Grease axle shaft, Loctite 243 (blue) on threads
16	1	BOLT	1805154	BOLT, MAIN PIVOT, 10 MM OD, M10x1.25, 86 MM L, 6 MM HEX	OVERTOP		14 Grease axle shaft, Loctite 243 (blue) on threads
17	1	BOLT, M8X18	1807126	BOLT M8 X 18MM CUSTOM. 6061 HARD BLACK ANO.	OVERTOP		8 Grease axle shaft, Loctite 243 (blue) on threads
18	2	BRG CUP	1800031	BEARING EYELET FOR 16X8X5 BRG	OVERTOP		
19	2	BRG SPACER	1800032	EYELET BEARING SPACER, T:6.3, FOR 40 MM LINK WIDTH	OVERTOP		
20	2	BUSHING, FOX	N/A	FOX_IGUS_BUSHING			
21	1	CABLE GUIDE	1995006	DOWNTUBE CABLE GUIDE FLUTE - 2025 INSTINCT POWERPLAY	CREATE THINK		
22	1	CABLE GUIDE	1995007	DOWNTUBE CABLE GUIDE WEDGE - 2025 INSTINCT POWERPLAY	CREATE THINK		
23	1	CABLE GUIDE	1995048	DOWNTUBE CABLE GUIDE WEDGE - SLIM - 2025 IPP	CREATE THINK		USE ONLY FOR ALLOY FT SIZE X-SMALL & SMALL
24	1	CHAIN GUIDE	1995013	MOTOR OUTPUT CHAIN GUIDE, 2025 INSTINCT POWERPLAY	CREATE THINK		
25	2	CHAINRING BOLT	1805173	CHAINRING BOLT, CUSTOM, M8 X 0.75, LENGTH 6MM	OVERTOP		
26	1	CHAINSTAYS	SEE TABLE	CHAINSTAYS - MY25 INSTINCT POWERPLAY	MK (RANBOW)		
27	1	COVER	1995005	BOTTOM BRACKET COVER, CO-MOLDED, 2025 IPP	CREATE THINK		
28	1	COVER	1995016	MAIN PIVOT COVER, 2025 INSTINCT POWERPLAY	CREATE THINK		
29	1	COVER	1995017	DS COVER, 2025 INSTINCT POWERPLAY	CREATE THINK		
30	1	COVER	1995018	FOR X-SMALL ONLY, BOTTOM BRACKET COVER, 2025 INSTINCT POWERPLAY	CREATE THINK		
31	1	FRONT TRIANGLE	SEE TABLE	FRONT TRIANGLE - MY25 INSTINCT POWERPLAY	MK (RANBOW)		
32	1	HANGER	1092003	MY22 REAR DER. HANGER, M12X1, UDH COMPATIBLE	OVERTOP		
33	1	HANGER NUT	1801008	RMB UDH HANGER NUT, 7075_T6, HARD BLACK ANODIZED	OVERTOP		20 Apply loctite 243 (Blue) on hanger's external threads only
34	1	HT PORT COVER	1803012	2023 SLAYER CARBON HT PORT COVER, RIGHT	OVERTOP		
35	1	HT PORT COVER	1803013	2023 SLAYER CARBON HT PORT COVER, LEFT	OVERTOP		
36	1	LINK	1095001	MY25 INSTINCT POWERPLAY - LINK A	MK (RANBOW)		
37	1	LINK	1095002	MY25 INSTINCT POWERPLAY - LINK B	MK (RANBOW)		
38	1	LINK	1095003	MY25 INSTINCT POWERPLAY - LINK C	MK (RANBOW)		DO NOT ORDER, DO NOT INCLUDE
39	1	PLATE	1094020	REAPER POWERPLAY LOWER PULLEY PLATE	OVERTOP		
40	1	PLATE	1995015	CHARGE PORT PLATE, 2025 INSTINCT POWERPLAY	CREATE THINK		
41	3	PORT COVER	1093011	ALLOY CABLE PORT COVER DOUBLE HOLE	CREATE THINK		
42	1	PORT COVER	1093012	ALLOY CABLE PORT COVER BLANK	CREATE THINK		
43	1	PORT COVER	1093013	ALLOY CABLE PORT COVER SINGLE 4mm HOLE	CREATE THINK		
44	1	PORT COVER	1093014	ALLOY CABLE PORT COVER SINGLE 5mm HOLE	CREATE THINK		
45	1	PROTECTOR	1705003	DOWNTUBE PROTECTOR - A - 2025 INSTINCT POWERPLAY	CREATE THINK		
46	1	PROTECTOR	1705004	DOWNTUBE PROTECTOR - B - 2025 INSTINCT POWERPLAY	CREATE THINK		
47	1	PROTECTOR	1705005	DOWNTUBE PROTECTOR - C - 2025 INSTINCT POWERPLAY	CREATE THINK		
48	1	PROTECTOR	1705006	2025 INSTINCT POWERPLAY CHAINSTAY PROTECTOR	CREATE THINK		
49	1	PROTECTOR	3702021	SEATSTAY PROTECTOR, TRIMMED	VELO		
50	1	RIDE 4 CHIP	1802009	RIDE 4 CHIP, NO THREAD.	OVERTOP		
51	1	RIDE 4 CHIP	1802010	RIDE 4 CHIP, THREADED, M8 x 1.	OVERTOP		
52	1	RUBBER CAP	1995014	CHARGE PORT RUBBER CAP, 2025 INSTINCT POWERPLAY	CREATE THINK		
53	1	SCREW	1800024-BK	C'SUNK SOCKET SCREW, M4x10MM, 10.9 STEEL, BLACK	OVERTOP		1 Apply grease on screw threads
54	1	SCREW	1802012	UDH STOP SCREW M4X8	OVERTOP		2 Apply loctite 243 (Blue) on screw threads
55	7	SCREW	1804060	M4X0.7, 10MM, 2.5 HEX, BUTTON HEAD, SS, BLACK	OVERTOP		1 Apply grease on screw threads
56	5	SCREW	1804063	LOW PROFILE SOCKET HEAD SCREW, M5X10, STAINLESS STEEL, BLACK	OVERTOP		2 Apply grease on screw threads
57	2	SCREW	1804065	M6 X 14MM, LOW BUTTON HEAD SCREW, SS, BLACK COATED	OVERTOP		4 Dry installation
58	2	SCREW	1805077-BK	C'SUNK SOCKET SCREW, M4X16, STAINLESS STEEL, BLACK	OVERTOP		1 Apply grease on screw threads
59	1	SCREW	1805157	MOTOR MOUNTING SCREW, M8x1.25, 10 MM L, 304 SS, BUTTON HEAD	OVERTOP		10 Apply Loctite 243 (blue) on screw threads
60	5	SCREW	1805158	MOTOR MOUNTING SCREW, M8x1.25, 18 MM L, 304 SS, BUTTON HEAD	OVERTOP		14 Apply Loctite 243 (Blue) on screw threads
61	6	SCREW	1805160	SCREW, BUTTON HEAD, 18-8 SS, BLACK, M3X0.5, L:8MM	OVERTOP		0.5 Apply grease on screw threads
62	1	SCREW	1805170	SCREW, BUTTON HEAD, 18-8 SS, RAW STAINLESS, M6X1.0, 12MM LENGTH	OVERTOP		4 Dry installation
63	2	SCREW	1805171	SCREW, BUTTON HEAD, 18-8 SS, BLACK, M6X1.0, 25MM LENGTH	OVERTOP		8 Apply loctite 243 (Blue) on screw threads
64	1	SCREW, M4X20	1809011	C'SUNK SOCKET SCREW, M4x20mm, STAINLESS STEEL 316	OVERTOP		2 Apply loctite 243 (Blue) on screw threads
65	1	SCREW, M5X12	1807152	C'SUNK SOCKET SCREW, M5-0.8x12mm. STAINLESS BLACK	OVERTOP		2 Apply loctite 243 (Blue) on threads
66	1	SEATSTAYS	SEE TABLE	SEATSTAYS - MY25 INSTINCT POWERPLAY	MK (RANBOW)		
67	1	SHOCK BUSHING	N/A	SHOCK BUSHING, ID:12.7mm, OD:15mm, L:12.7mm, STEEL			
68	2	SHOCK REDUCER	N/A	FOX STD REDUCER FOR 25MM PIN			
69	2	SHOCK REDUCER	N/A	SRAM STD REDUCER FOR 25MM PIN			
70	1	SHOCK, PIN	N/A	SHOCK PIN: ID:8 x 25 mm LONG; ALUMINUM			
71	1	SLEEVE	1800008	TT BEARING SLEEVE, ID:10, OD:14, L:29	OVERTOP		
72	1	SLEEVE	1800010	SS BEARING SLEEVE, ID:10, OD:14, L:41, NECKED	OVERTOP		
73	2	SLEEVE	1800040	DROPOUT BEARING SLEEVE, OD:14, ID:8, T:1.8, 6061 ALU	OVERTOP		

## TEILELISTE UND MONTAGEANLEITUNG

74	1 SLEEVE	1805156 SLEEVE, MAIN PIVOT, 10MM ID, 52.5 MM L	OVERTOP	Grease bearing contact surfaces before installation
75	1 SLEEVE	1807028 BEARING EYELET CENTRE SLEEVE	OVERTOP	
76	1 SPACER	1347013 CHAINSTAY PULLEY GUIDE SPACER,	OVERTOP	
77	4 SPACER	1800009 LINK BEARING SPACER, OD:22, ID:10, T:2.5	OVERTOP	
78	4 SPACER	1800039 DO BEARING SPACER, OD:16, ID:8, T:1.75, 6061 ALU	OVERTOP	
79	2 SPACER	1805191 CHAINGUIDE SPACER, 0.5MM, 304 STAINLESS STEEL, 2025 IPP	OVERTOP	
80	1 SPACER	3399006 LOWER CHAIN GUIDE SPACER	SHING FONG	
81	3 WASHER	1800019 WASHERID: 10.2, OD: 15.5, T:1	OVERTOP	
82	1 WASHER	1801009 WASHER, 20X24X0.5MM, 304 SS	OVERTOP	
83	2 WASHER	1805155 WASHER, MAIN PIVOT, 15MM ID, 27.5MM OD, 2.5MM T	OVERTOP	
84	3 WASHER	1805172 WASHER, 6x10x0.5MM, 304 SS	OVERTOP	
85	1 WASHER	3227006 WASHER, 12x19x0.5MM, 304 SS	OVERTOP	

## BILDER



## JUMBOTRON

Das Jumbotron-Display ist das Kommunikationszentrum deines Powerplay™-Bikes. Es dient der Bedienung des Systems, der Anzeige von Informationen und der Diagnose und Problembeseitigung. Firmware-Aktualisierungen werden bei Bedarf über das USB-Modul und einen Computer durchgeführt.



## STEUERUNGEN FÜR FAHRER

### DMS (Daumen-Maschine-Schnittstelle, alias die Fernbedienung)



### ANZEIGE



## FAHRT

### Warnung

Stellen Sie sicher, dass die Bremsen angezogen sind bevor Sie Druck auf die Pedale ausüben oder auch nur Ihren Fuß auf die Pedale setzen. Der Powerplay™-Antrieb verwendet eine ausgeklügelte Drehmomentsensorschaltung um weiche, sofortige, sich natürlich anfühlende Kraft zu liefern. Diese Schaltung ist sehr empfindlich. Deshalb ist Vorsicht geboten, damit das Rad nicht aus dem Stand vom Fahrer weg beschleunigt.

### Einschalten

Halten Sie die Taste am Jumbotron 2 Sekunden gedrückt, um den Powerplay™-Antrieb zu aktivieren und das Fahrrad einzuschalten. HINWEIS: Der Powerplay™-Antrieb wird immer im zweitniedrigsten Unterstützungsmodus aktiviert. Der Fahrer kann die Unterstützung dann mit der Fernbedienung oder dem Jumbotron erhöhen.

### Unterstützungsstufen

Der Powerplay™-Antrieb stellt mehrere Stufen der Unterstützung zur Verfügung:

#### Stufe 1: Eco

Dies ist die geringste Unterstützungsstufe mit der maximalen Akkulaufzeit.

#### Stufe 2: Trail

Die Stufe hält die Balance zwischen Unterstützung und Akkulaufzeit für den universalen Einsatz.

#### Stufe 3: Trail+

Diese Stufe gibt dem Fahrer ausreichend Schub für eine tolle Fahrt und eine gute Geschwindigkeit, um ihn ohne leeren Akku zu den Abfahrten zu bringen.

#### Stufe 4: Ludicrous

Für maximale Geschwindigkeit und Unterstützung liefert diese Stufe eine große Menge Energie an das Hinterrad. Beachten Sie, dass der Akku auf dieser Stufe relativ schnell entladen wird. Verwenden Sie die Fernbedienung (Taste aufwärts oder abwärts) oder klicken Sie die Taste am Jumbotron, um die Unterstützungsstufen zu wechseln.

HINWEIS: DER FAHRER KANN DIE KRAFTEINSTELLUNGEN ALLER 4 MODI SOWIE DEN MOTOR-BOOST (DREHMOMENT-SENSITIVITÄT) IM HAUPTMENÜ INDIVIDUELL  EINSTELLEN. ZUM ZUGANG GEDRÜCKT HALTEN.

## DAS BIKE FAHREN

Das Dynamie S4 Lite Antriebssystem verfügt über einen einstellbaren Kindermodus, über den die Eltern Geschwindigkeit und Leistungslimit für das Instinct Powerplay SL™ Fahrrad ihres Kindes festlegen können.

Um den KINDERMODUS zu aktivieren, halte ⚡ auf der Mikro-Fernbedienung gedrückt und gehe zu den Einstellungen.

### MENÜ Kindersicherung

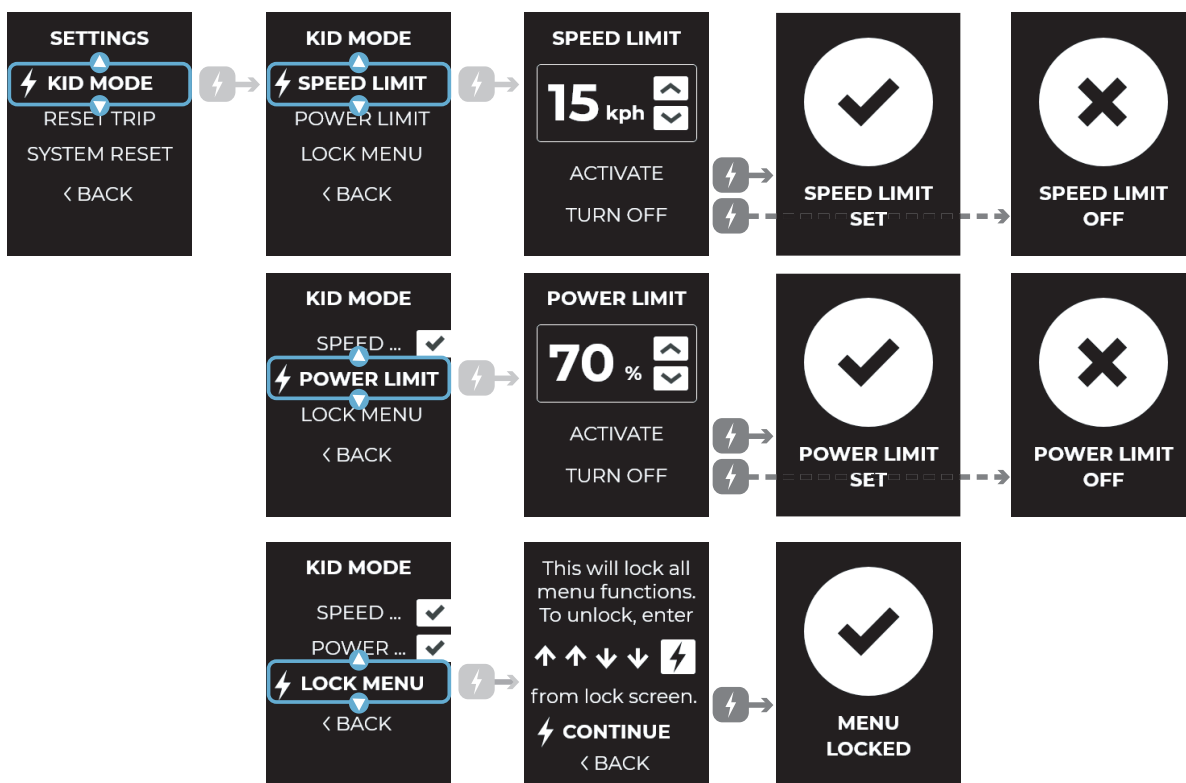

#### Sobald es gesichert ist



Wenn die Menü-Taste gehalten wird, erscheint die Anzeige Menü gesperrt. \*Seite überschreitet das Zeitlimit nach 5 Sekunden, wenn kein Code eingegeben wurde

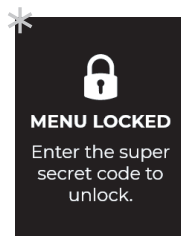

#### Sequenz zum Entsichern



Wenn diese Sequenz eingegeben wurde, erscheint die Anzeige „Menü entsperrt“ und die normalen Menüfunktionen sind wieder verfügbar



## EINSTELLUNG DER UNTERSTÜTZUNG

Unterstützungsstufen können beim Start oder jederzeit während der Fahrt angepasst werden. Das Dynam™ 4.0 System kann 3 verschiedene Unterstützungskarten in seinem Speicher behalten: eine Standard-WERKS-Karte und zwei personalisierbare Abstimmungen. Der Fahrer kann das Verhalten des Antriebs zwischen den Karten entsprechend auswählen.

### Abstimmung auswählen

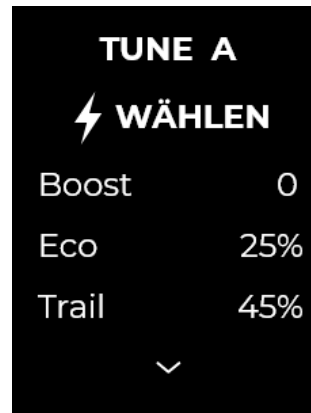
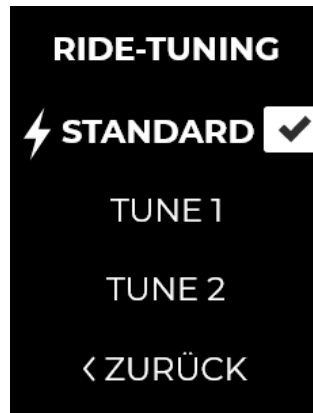

### Abstimmung anpassen

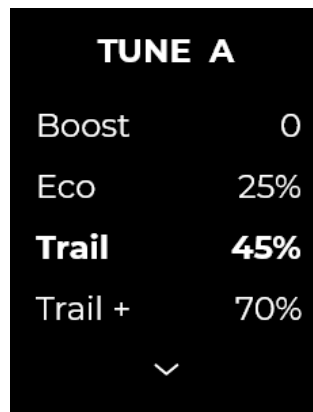
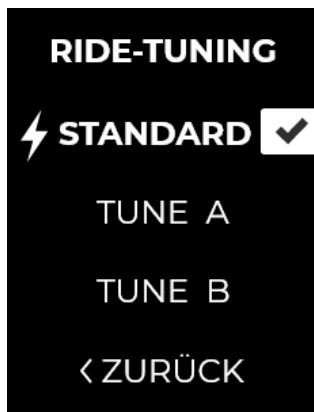

### 2 anpassbare Parameter

- Boost: Wie der Motor auf den Input des Fahrers reagiert (Drehmoment-Sensitivität oder %-Boost)

- Unterstützungskraft: % der verfügbaren Kraft für jede der 4 Unterstützungsstufen

## EINSTELLUNG DER UNTERSTÜTZUN

### Motor boost



#### Anpassung von +2 bis -2

**+2** Sehr wenig Anstrengung des Fahrers erforderlich. Maximaler Boost, minimale Akkureichweite.

**0** Ausgewogene Leistung, gutes Ansprechen und gute Akkureichweite.

**-2** Erheblicher Kraftaufwand des Fahrers erforderlich, maximierte Akkureichweite, bestes Training.

### Unterstützungskraft

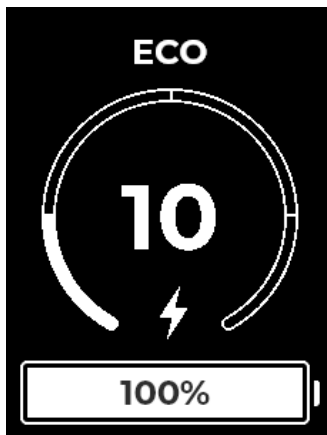

#### Anpassung von 1 % bis 100 %

Für jeden der 4 Unterstützungsmodi (Eco, Trail, Trail+, Ludicrous) können Sie die Motorleistung auswählen, angegeben als Prozentsatz der verfügbaren Maximalleistung. Sie können die Leistung eines hohen Unterstützungsmodus nicht niedriger als in einem niedrigeren Unterstützungsmodus einstellen, z. B. kann der Trail-Modus nicht niedriger als der Eco-Modus eingestellt werden.

## AKKU

Das Instinct Powerplay SL™ ist mit proprietären Steuerungen, Motoren und Komponenten ausgerüstet. Einige dieser Komponenten sind empfindlich und erfordern einen besonders sorgfältigen Umgang. Wir möchten dir so viele Informationen wie möglich zur Verfügung stellen. Bitte beachte die folgenden aktualisierten Informationen zu den Rocky Mountain Powerplay™-Akkus, zum Laden und zu deren Pflege. Die Nichtbeachtung der Anweisungen und Richtlinien in diesem Abschnitt kann zu Schäden an den elektrischen Komponenten deines Fahrrads und zum Verlust deiner Garantieansprüche führen. Darüber hinaus kann die Nichtbeachtung der Anweisungen zu schweren oder tödlichen Verletzungen führen.

### Allgemeines

- Die Akkus aller Rocky Mountain Powerplay™-Geräte weisen die von den Behörden vorgeschriebenen Zertifizierungen auf und haben ein integriertes Batteriemanagementsystem (BMS) mit mehreren Schutzebenen, um Gefahren zu vermeiden. Trotz dieser Sicherheitsmaßnahmen kann Gefahr von einem geladenen Akku unter extremen Temperaturen oder einem beschädigten Ladeanschluss ausgehen und es kann zu einem Stromschlag, Feuer, oder Verletzungen kommen.
- Verwende bei Anzeichen der Beschädigung am Akku oder am Ladegerät diese nicht weiter und bringe dein Fahrrad zur Überprüfung zu einem autorisierten Rocky Mountain Händler.
- Der Akku und die Antriebseinheit, sowie andere proprietäre Powerplay™-Komponenten dürfen nur von Mechanikern gewartet werden, die eine Rocky Mountain Powerplay™-Schulung absolviert haben.
- Es ist darauf zu achten, dass keine kleinen, spitzen und/oder metallischen Objekte in Kontakt mit Akkus oder Ladeanschlüssen kommen.
- Akku und Ladegerät dürfen nicht verändert, geöffnet oder auseinandergenommen werden.
- Wasche ein Powerplay™ nie mit einem Hochdruckreiniger und tauche es nie in Wasser ein. Regen und normales Waschen stellen kein Problem dar.
- Unbeschädigte Akkus setzen keine Flüssigkeiten oder Gase frei. Die Akkuflüssigkeit von beschädigten Akkus kann jedoch zu Reizungen und Verätzungen der Haut führen und die freigesetzten Gase können die Atemwege reizen. Wenn die von Akkus freigesetzten Flüssigkeiten oder Gase mit der Haut oder den Augen in Kontakt kommt, sofort mit Wasser ausspülen und umgehend einen Arzt aufsuchen.
- Wenn das Fahrrad mit entferntem Akku auf einem Auto transportiert wird, stelle bitte sicher, dass alle Anschlüsse abgedeckt sind, um Verschmutzung durch Straßenschmutz, Wasser und Salz zu vermeiden.
- Lösche einen Brand des Akkus nie direkt mit Wasser. Wasser kann zum Löschen des Feuers auf den Werkstoffen um den Akku herum verwendet werden, aber nicht auf den chemischen Zellen des Akkus. Verwende zum ordnungsgemäßen Löschen des Feuers einen Feuerlöscher für die Brandklasse ABC oder BC. Sand kann dazu benutzt werden, ein Feuer wirksam zu ersticken. Wenn möglich, ohne sich dabei selbst in Gefahr zu begeben, bringe den erhitzten oder entzündeten Akku nach draußen, um ein Ausbreiten des Feuers zu vermeiden. Wenn der Akku an ein Ladegerät angeschlossen ist, sollte als erstes das Ladegerät abgezogen oder der Strom abgeschaltet werden.

### Aufladen

- Es dürfen nur dafür vorgesehene Powerplay™-Ladegeräte für Powerplay™-Akkus eingesetzt werden.
- Das Ladegerät darf keiner direkten Sonneneinstrahlung ausgesetzt werden, insbesondere nicht während des Ladevorgangs.

### So wird der Akku geladen:

1. Die Schutzabdeckung vom Ladeanschluss des Powerplay™-Bikes abnehmen.
2. Beachten Sie die Form des Ladekabelsteckers und richten Sie ihn korrekt zum Ladeanschluss am Fahrrad aus. Schließen Sie das Ladegerät an das Powerplay™-Bike an.
3. Schließen Sie das Ladegerät an eine Steckdose an. Das LED-Kontrolllicht am Ladegerät leuchtet rot auf, um den Ladevorgang anzuzeigen.



## AKKU

4. Dieses Ende des Ladevorgangs stellt die letzten 3 % der Akkuladung dar. Du kannst das Ladegerät jederzeit entfernen, wenn du mit dem Ladezustand des Akkus zufrieden bist.

### HINWEISE:

1. Verwechsle dieses Ende des Ladevorgangs nicht mit einer Systemstörung, bei der das Ladegerät schnell blinkt.
2. Dieses Ende des Ladevorgangs stellt die letzten 3 % der Akkuladung dar. Du kannst das Ladegerät jederzeit entfernen, wenn du mit dem Ladezustand des Akkus zufrieden bist.
  - Laden Sie Ihr Powerplay™-Bike auf einer offenen Fläche mit einem direkten Ausgang ins Freie auf.
  - Ähnlich wie bei allen anderen Bikes und Geräten, die eine Lithium-Ionen-Akku verwenden, wird empfohlen, das Bike nur unter Aufsicht zu laden.
  - Wenn der Akku 50 °C erreicht, wird der Ladevorgang gestoppt, bis die Akkutemperatur auf 45 °C fällt. Wenn die Akkutemperatur 0 °C erreicht, wird der Ladevorgang gestoppt, bis die Akkutemperatur auf 3 °C steigt.
  - Die Ladezeit hängt von der verbleibenden Ladung des Akkus ab.

- Zu erwartende Ladezeiten:

480 Wh	4A Ladegerät	2A Ladegerät
Ladezeit von 0–80 %	1h55	4h00
Ladezeit von: 0–95 %	2h20	4h40
Gesamtladezeit: 0–100 %	2h35	5h05

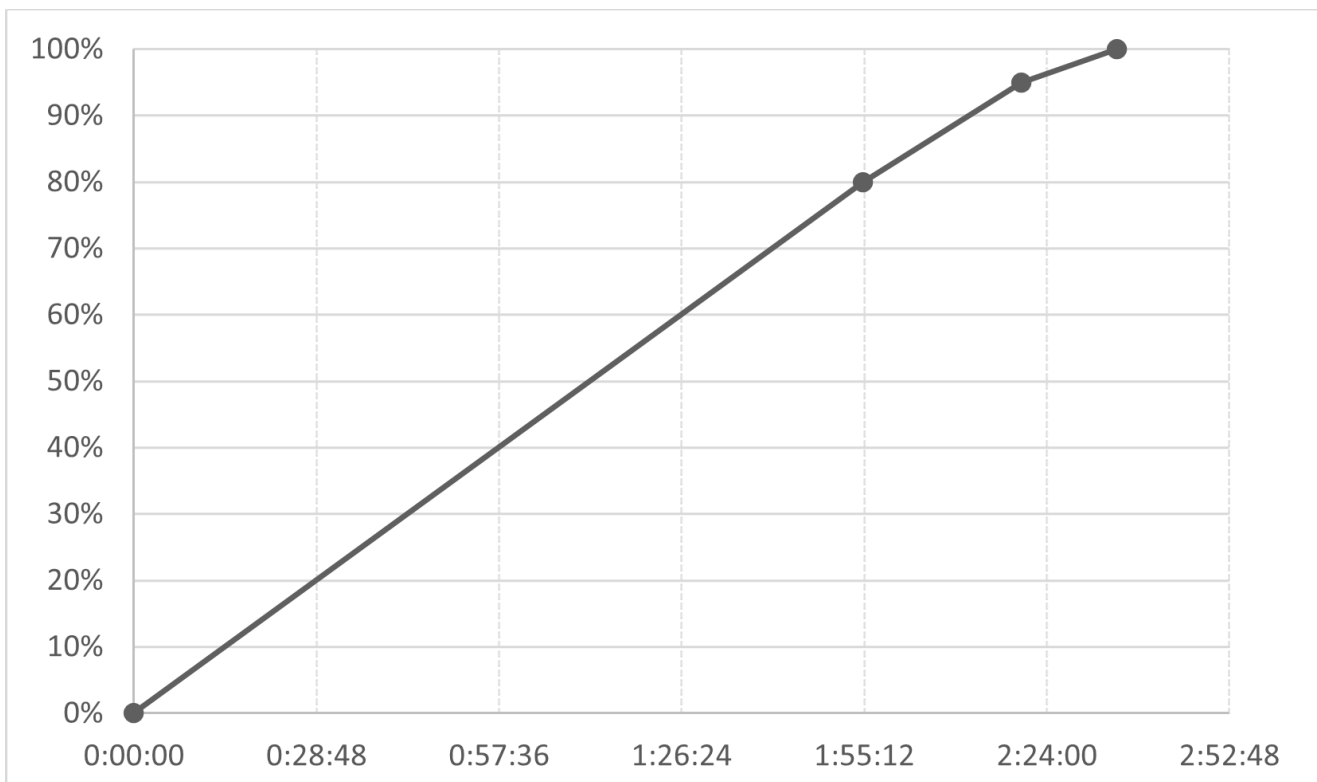

## AKKU

### Lagerung

- Lagere dein Instinct Powerplay SL™ Fahrrad an einem sicheren Ort, der keinen extremen Temperaturen (über 30 °C oder unter -20 °C), übermäßiger Sonneneinstrahlung, Feuchtigkeit oder Kondensation ausgesetzt ist. Wenn du glaubst, dass das Fahrrad unsachgemäß gelagert wurde und obengenannten Bedingungen ausgesetzt wurde, stelle bitte sofort die Benutzung ein und suche einen Rocky Mountain Vertragshändler auf.
- Ein vollständig entladener Akku, der für längere Zeit gelagert wird, kann Schaden nehmen und es kann ein Kapazitätsverlust eintreten. Es wird empfohlen, den Akku nach Möglichkeit auf mindestens 75 % zu laden, um einem Schaden durch Tiefentladung über längere Zeit vorzubeugen und damit den Garantieanspruch zu verlieren. Wird ein Fahrrad über einen langen Zeitraum gelagert, muss der Akku regelmäßig aufgeladen werden, mindestens alle drei Monate, um seine Kapazität zu erhalten. Andernfalls kann es zu Schäden am Akku kommen und ein Kapazitätsverlust eintreten. Um während der Lagerung daran zu denken, Ihren Akku aufzuladen, nutzen Sie automatische Erinnerungen durch einen Kalendereintrag in Ihrem Computer oder Handy.
- Die optimale Akkukapazität bleibt bei einer Lagerung zwischen 10° C und 25° C und bei einer relativen Luftfeuchtigkeit unter 65 % erhalten.
- Nach 1 Monat Lagerung wechselt die Batterie in einen Schutzmodus.

### Funktionsfähigkeit des Akkus

- Der Akku funktioniert auch bei kaltem Wetter, jedoch mit geringerer Kapazität. Dabei ist mit ca. 70 % der vollen Kapazität bei -10° C zu rechnen. Es ist empfehlenswert, das kalte Bike vor der Verwendung aufzuwärmen.
- Wenn eine Akkutemperatur von 65° C erreicht wird, schaltet sich dieser zum Schutz ab, bis er auf unter 60° C abgekühlt ist. Wenn eine Akkutemperatur von -20° C erreicht wird, schaltet sich dieser zum Schutz ab, bis er sich auf mindestens -15° C erwärmt hat.
- Wenn der verbleibende Akkustand niedrig ist, verringert der Powerplay™-Antrieb nach und nach seine Leistung, um die Reichweite zu maximieren.
- Bitte beachten Sie, dass Lithium-Ionen-Akkus allmählich Kapazität verlieren, abhängig vom Alter und der Verwendung. Eine drastische Verringerung der Kapazität kann ein Zeichen dafür sein, dass der Akku das Ende seiner Lebensdauer erreicht hat und ersetzt werden muss. Bitte lassen Sie Ihren Akku in diesem Fall von einem autorisierten Rocky Mountain Händler auswechseln. Bei normalem Gebrauch ist zu erwarten:

#### 480 Wh

Kapazität von 80 % nach 500 vollen Ladezyklen (Ladung von 0 % auf 100 %).

## AKKU

### Akku LED

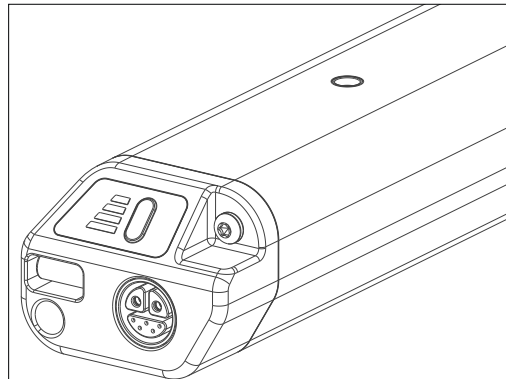

### Akkustandsanzeige

- Anzeigetaste kurz drücken**

Drücke die Anzeigetaste beim Einschalten für weniger als 1 Sekunde.

#### LED-ANZEIGE AKKUSTAND (LED 4,3,2,1)

#### Verbleibende Akkukapazität

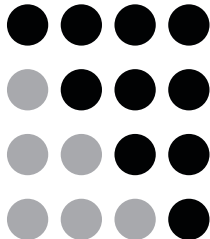

100%-75%

74,9%-50%

49,9%-25%

24,9%-0%

### Während des Ladevorgangs

- Anzeige Verlauf Ladevorgang**

#### LED-ANZEIGE AKKUSTAND (LED 4,3,2,1)

#### Verbleibende Akkukapazität

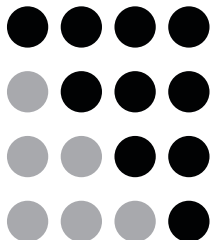

100%-75%

74,9%-50%

49,9%-25%

24,9%-0%

○ : Kein Licht

● : Dauerlicht

⦿ : Blinkend

## FAHRERBILDSCHIRME

Entsprechend der Auswahl zeigt das Display eine Kategorie von Informationen an, während wichtige Daten ebenfalls angezeigt werden. Dieser Bildschirm zeigt für Rennen angemessene Informationen wie Geschwindigkeit, Trittfrequenz, Unterstützungsstufe und Boost-Stufe an, alles auf einem Bildschirm.

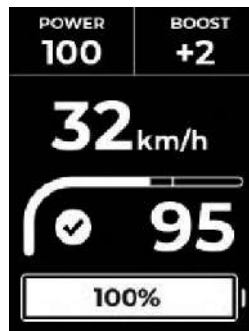
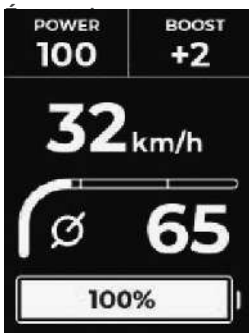

Unterstützungsstufe

Aktuelle  
Geschwindigkeit

Akkustand



Unterstützungsstufe

Akkustand in Prozent

Akkustand

## FAHRERBILDSCHIRME

### Unterstützungsanzeige

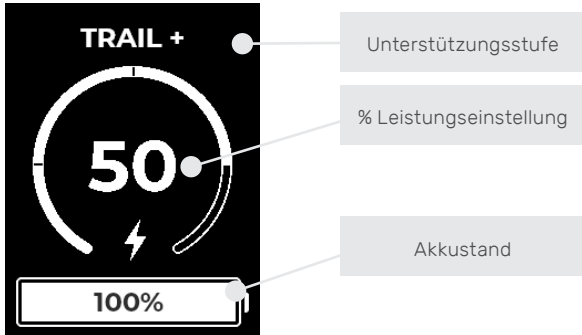

### Trittfrequenzanzeige

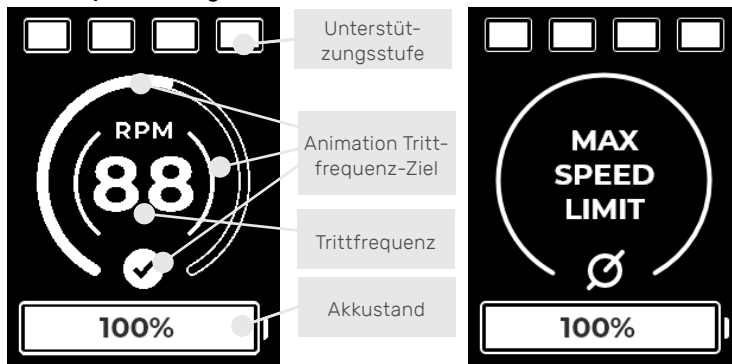

Beachte, dass die Trittfrequenz über die Motordrehzahl ermittelt wird und eine Schätzung ist. Das bedeutet auch, dass bei abgeschaltetem Motor (Bsp.: über der Höchstgeschwindigkeit) keine Trittfrequenz angezeigt wird.

### Ansicht

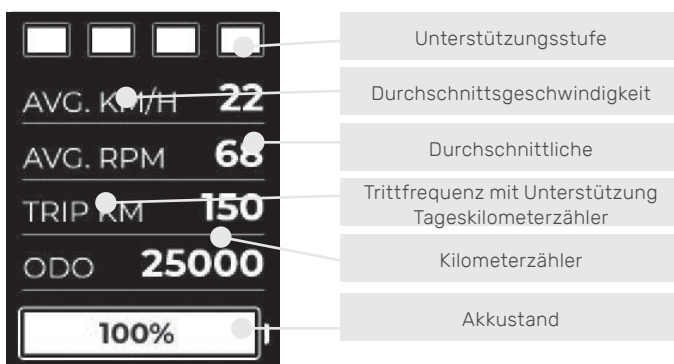

## ZURÜCKSETZEN

Der Fahrer kann die Fahrtinformation (Durchschnittsgeschwindigkeit, durchschnittliche Trittfrequenz, Fahrtstrecke) immer zurücksetzen und das Dynamen System auf die ursprünglichen Werkseinstellungen zurücksetzen.

### Fahrt zurücksetzen

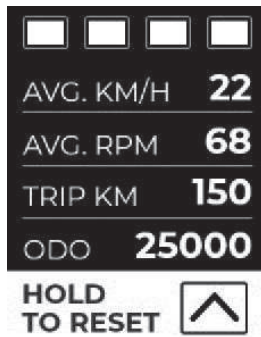

In der Kilometerstandanzeige die Taste AUFWÄRTS am DMS gedrückt halten oder

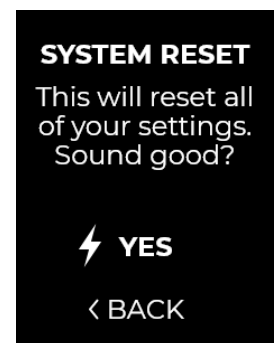
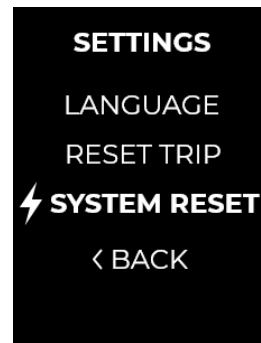
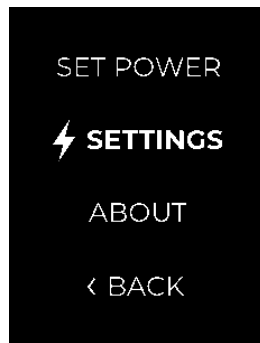

Von beliebigem Fahrerbildschirm durch HALTEN von  ins Hauptmenü gehen. Gehe zu Einstellungen – System zurücksetzen.

### Schiebe-Modus

Sollte es nötig sein, hat das Powerplay™ einen Schiebe-Modus. Der Powerplay™ Antrieb ist in der Lage, das Fahrrad bei Schrittgeschwindigkeit zu unterstützen. Drücke und halte die Taste WENIGER auf der Fernbedienung. Das Rad wird dich langsam beim Schieben unterstützen. Der Schiebe-Modus darf nicht verwendet werden, während sich ein Fahrer auf dem Fahrrad befindet. Der Schiebe-Modus darf nur beim Gehen neben dem Fahrrad verwendet werden.

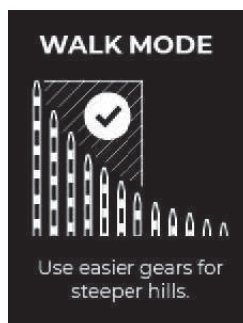

### Ausschalten

Zum Ausschalten des Powerplay™ -Antriebs die Taste am Jumbotron gedrückt halten. Wenn das Fahrrad 10 Minuten lang nicht bewegt wird, schaltet sich der Antrieb automatisch ab, um Strom zu sparen.

### Eingabeaufforderung

Erscheint, nachdem der Ein-/Ausschalter 0,5 Sekunden lang gedrückt wurde.



### Abschalten

Erscheint, nachdem der Ein-/Ausschalter 2,5 Sekunden lang gedrückt wurde.

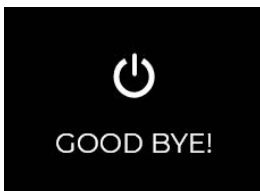

## HINWEISE

### Beschädigung an der Fernbedienung

Falls die Fernbedienung beschädigt ist und nicht mehr funktioniert, kann der Fahrer das Fahrrad weiter nutzen und die Unterstützungsmodi mit dem Jumbotron wechseln.

HINWEIS: Die Menüs und Anpassungen sind über das Jumbotron ohne die Fernbedienung nicht zugänglich.

### Reichweite

Die Reichweite hängt von vielen Faktoren ab, wie zum Beispiel der Unterstützungsstufe und dem gewählten Unterstützungsmodus, der Umgebungstemperatur, der Beschleunigung, dem Windwiderstand, dem Wartungsstand, dem Alter des Akkus, hügeligem und rauem Gelände und/oder dem Gewicht des Fahrers.

### Fahrtipps

- Der Dynam S4 Lite -Antrieb liefert weiche, sich natürlich anfühlende Kraft an das Hinterrad und funktioniert am besten unter diesen Umständen.
- Tritt moderat und durchgängig in die Pedale, statt sie zu stark zu beanspruchen.
- Schalte häufig, um die Trittfrequenz zwischen 80 und 120 U/min zu halten, den Motorwirkungsgrad optimal auszunutzen, ein hohes Drehmoment zu erhalten und den Akku optimal auszunutzen. Verwende die Trittfrequenzanzeige am Jumbotron, die den Fahrer informiert, wenn er im effizienten Bereich fährt.
- Beim Schalten ist Vorsicht geboten:
- Verringere den Pedaldruck, bevor du schaltest, um die Kette nicht zu belasten.
- Schalte nicht mehrere Gänge auf einmal.

## SERVICE

### Diagnose und Reparatur

Das Jumbotron kann Fehlermeldungen anzeigen und dem Fahrer in manchen Fällen Anweisungen zur Reparatur des Systems gegen.

#### Beispiel



### Kalibrieren

Ein Kalibrierungsverfahren kann gelegentlich erforderlich sein, um die Leistungsfähigkeit des Antriebssystems zu erhalten. Normalerweise wird dies durchgeführt, wenn eine Komponente der Antriebsgruppe ersetzt (Kette, Kettenblatt, Antriebsritzeln etc.) oder der Motor wieder in den Rahmen eingebaut wird.



## SERVICE

### Fehlerbehandlung

Bitte arbeiten Sie zur Fehlerbehandlung mit ihrem Händler vor Ort zusammen. Ihr Jumbotron Display kann Fehlercodes für Diagnosen generieren. Wenn ein Fehlercode erscheint, wird das System Ihnen Anweisungen geben. In manchen Fällen kann eine Reparatur unterwegs möglich sein, andernfalls muss sich der Fahrer eventuell an einen autorisierten Händler wenden. Manche Fehler führen zu einem Notbetrieb, der dem Fahrer die Heimfahrt mit reduzierter Leistung ermöglicht.

### WARNUNG

WARNUNG – Nehmen Sie keine unerlaubten Änderungen an Ihrem Rocky Mountain Bike vor, d. h., entfernen oder ersetzen Sie keine Originalteile und nehmen Sie keine Modifikationen an Ihrem Rocky Mountain Bike vor, die das Design und/oder den Betrieb verändern könnten. Solche Modifikationen können das Fahrverhalten, die Stabilität und andere Aspekte des Fahrrads ernsthaft beeinträchtigen und die Fahrsicherheit gefährden. Derartige Modifikationen können zum Erlöschen der Garantie führen. Außerdem entspricht ein modifiziertes Rocky Mountain Bike ggf. nicht mehr den geltenden Gesetzen und Vorschriften des Landes, in dem das Fahrrad gefahren wird. Um Sicherheit, Qualität und Zuverlässigkeit zu gewährleisten, verwenden Sie für Reparaturen und Austausch nur Originalteile oder von Rocky Mountain Bicycles zugelassene Ersatzteile. Rocky Mountain Bicycles haftet nicht für direkte, beiläufige oder Folgeschäden, einschließlich, ohne Einschränkung, Personen- oder Sachschäden oder wirtschaftliche Verluste aufgrund von Modifikationen.

#### *Achtung:*

Der A-bewertete Emissionsschalldruckpegel an den Ohren des Fahrers beträgt weniger als 70 dB[A].



## ALLGEMEINE WARTUNG

Bitte beachten Sie, dass elektrisch unterstützte Fahrräder größeren Lasten ausgesetzt sind und dadurch einen höheren Verschleiß an ihren Teilen haben als gewöhnliche Fahrräder. Sie sollten daher häufiger geprüft und gewartet werden, um die Sicherheit, Leistung und Langlebigkeit zu maximieren.

### Langzeitlagerung

Wenn Sie Ihr Fahrrad längere Zeit nicht benutzen, sollte der Akku mindestens alle drei Monate geladen werden. Werden diese Ladeabstände überschritten, kann der Akku Schaden nehmen und die Kapazität verringert sich. Nach einem Monat ohne Benutzung wechselt der Akku in einen Schutzmodus. Schließen Sie den Akku an das Ladegerät an, um ihn zu reaktivieren.

Automatische Erinnerungen durch einen Kalendereintrag im Handy oder Computer sind eine bewährte Möglichkeit, das Aufladen nicht zu vergessen.

### Reinigung

Ein sauberes Fahrrad ist ein glückliches Fahrrad. Der beste Weg, um ein Fahrrad zu reinigen, ist ein Eimer mit warmem Wasser und Seife. Vermeiden Sie die Nutzung eines Hochdruckreinigers.

HINWEIS: Spritzen Sie kein Wasser direkt auf elektrische Bauteile.

### Vorbeugende Wartung

Säubern und inspizieren Sie die Antriebskomponenten auf Verschleiß

- Kette
- Zahnkränze
- Ritzel (Unteres Umlenkrizel, Umwerferritzel)
- Kettenblatt
- Antriebsritzeln

Überprüfen Sie Bolzen und Verschlüsse

- Alle Standard-Fahrradverschlüsse: Gelenke, Lenkervorbau, Kurbelbolzen,
- Kettenringbolzen
- Motoraufhängung
- Drehmomentsensor-Aufhängung
- Akku-Halterungsstift
- Überprüfen Sie die Speichenspannung
- Inspizieren Sie die Bremsbacken und -scheiben
- Halten Sie den Ladeanschluss sauber/geschlossen

## WARTUNG

Checkliste für regelmäßige Wartung und Einstellung	Checkliste					Hinweise
	500KM	1000KM	1500KM	2000KM	2500KM	
Fahrradkette - auf Verschleiß prüfen, reinigen und schmieren	Vor jeder Fahrt					Zustand prüfen (Dehnung, Risse) und mit dem vom Kettenlieferanten empfohlenen Schmiermittel schmieren.
Ladeanschluss	Vor jedem Ladevorgang					Auf eingedrungenes Wasser, Korrosion, Ausrichtung der Kontakte & Schmutz prüfen
Drehmomentsensor kalibrieren	Alle zwei Monate					ODER jedes Mal, wenn Sie eine Komponente des Antriebssystems oder der Antriebs- gruppe austauschen
Befestigungsschrauben des Motors	●	●	●	●	●	Auf korrektes Drehmoment prüfen.
Antriebsritzel & Sicherungsring	●	●	●	●	●	Zustand prüfen: immer austauschen, wenn Verschleißgrenze erreicht ist
Drehmomentsensor & Spannrolle	●	●	●	●	●	Auf Risse und Beschädigungen prüfen
Motorgehäuse & Abdeckungen		●		●		Auf Risse und Beschädigungen prüfen
Motorkabel		●		●		Die Isolierung und den Stecker auf Beschädigungen prüfen
Akkugehäuse	Jedes Mal überprüfen, wenn sich der Akku nicht im Fahrrad befindet.					Das Gehäuse und den Stecker auf Beschädigungen prüfen
Fernbedienung & Kabel am Lenker	●	●	●	●	●	Das Gehäuse und den Stecker auf Beschädigungen prüfen
Display & Kabel am Oberrohr	●	●	●	●	●	Auf übermäßiges Spiel und Schäden am Bildschirm prüfen
Verlängerungskabel am Unterrohr	●	●	●	●	●	Das Gehäuse und den Stecker auf Beschädigungen prüfen
Geschwindigkeitssensor & Kabel	Jedes Mal überprüfen, wenn sich das Laufrad nicht im Fahrrad befindet.					Das Gehäuse und den Stecker auf Beschädigungen prüfen; Sicherstellen, dass die Magnete ordentlich befestigt sind
Antriebskette - reinigen und schmieren		●		●		Zustand prüfen und mit demselben Öl schmieren, das für die Antriebskette verwendet wird
Antriebskette - austauschen	Alle 2500 km austauschen					Zustand prüfen, um internen Motorverschleiß und Geräusche zu vermeiden
Motor Kupplungslager - austauschen	Alle 2500 km austauschen					Lager auf reibungslose Funktion prüfen
Spider Kupplungslager - austauschen	Alle 2500 km austauschen					Lager auf reibungslose Funktion prüfen

## **ALLGEMEINE WARTUNG**

### **ERSATZTEILE UND ZUBEHÖR**

Bitte beziehen Sie Rocky Mountain Ersatzteile und Zubehör über Ihren örtlichen Rocky Mountain Vertragshändler. Wir empfehlen dringend, dass Sie einen Ersatzschlauch und das nötige Werkzeug für einen Schlauchwechsel dabei haben, wenn Sie mit dem Fahrrad unterwegs sind.

### **TRANSPORTATION**

Achten Sie beim Transport/Versand Ihres Fahrrades mit Powerplay™-Antrieb darauf, dass unter Umständen Beschränkungen auftreten können und besondere Behandlung, Beschriftung und/oder Verpackung nötig sind. Informieren Sie sich im Voraus über alle rechtlichen Anforderungen in Ihrem Land. Wenn das Fahrrad mit entferntem Akku auf einem Auto transportiert wird, stellen Sie bitte sicher, dass alle Anschlüsse abgedeckt sind, um Verschmutzung durch Straßenschmutz, Wasser und Salz zu vermeiden.

### **REGISTRIEREN**

Wenn Sie Ihr Bike registrieren, können wir Sie offiziell in der Rocky Mountain Familie willkommen heißen. Es ist auch ein wichtiger Schritt für die Aktivierung der Garantie Ihres Bikes. Sollten Sie irgendwann ein Problem haben, können wir Ihren Fall effizient bearbeiten und Sie schnellstmöglich wieder auf Ihr Bike bringen. Es ist einfach und dauert nur ein paar Minuten.

Register your bike: [bikes.com/register](https://bikes.com/register)

## GARANTIEINFORMATIONEN

Ihr Powerplay™-Fahrrad unterliegt einer Gewährleistung auf Material-, und Produktionsmängel gemäß folgender Tabelle:

KATEGORIE	LAUFZEIT	HINWEISE
Rahmenteile	5 Jahre	Vorderes Rahmendreieck + hinteres Rahmendreieck, Gelenke
Hardware	1 Jahr	Gelenke, Achsen etc.
Elektronische Bauteile	3 Jahre	Antrieb, Fernbedienung, Jumbotron, Sensoren, Ladegerät
Verschleißteile des Antriebs	1 Jahr	Kettenräder, Ritzel, Antriebskette
Akku	2 Jahre	Bei Lagerung von über 3 Monaten den Akku alle 3 Monate laden. Nichtbeachtung kann Schäden verursachen.
Komponenten	Gemäß Garantie des Originalherstellers	

Garantiefälle und Kundenservice müssen von dem autorisierten Rocky Mountain Händler durchgeführt werden, der das komplette Fahrrad oder den Rahmen verkauft hat. Wir decken Ihren Rocky Mountain-Rahmen ab dem ursprünglichen Kaufdatum Ihres neuen Fahrrads gegen Material- und Verarbeitungsfehler ab, je nach Rahmenmaterial und der Art der Nutzung des Fahrrads.

Die beschränkte Garantie von Rocky Mountain deckt auch Fahrräder, die zuvor für private und kommerzielle Aktivitäten wie Verleih (einschließlich Fahrradparks), Kurierdienst, Polizeidienst, Sicherheitsdienst usw. verwendet wurden, gegen Material- und Verarbeitungsfehler ab. Die beschränkte Garantie gilt für den Rest der Garantiezeit ab dem ursprünglichen Kaufdatum bei Rocky Mountain. In solchen Fällen sind Hardware, Lager, Drehzapfen und Buchsen von unserer Garantie ausgeschlossen. Der Original-Kaufbeleg, die Bestätigung der Fahrradregistrierung oder ein anderer Kaufnachweis ist für alle Ansprüche erforderlich.

Bei Fahrrädern ab dem Modelljahr 2021 ist die ursprüngliche beschränkte Garantie auf den Zweitbesitzer übertragbar. Die beschränkte Garantie gilt nur dann, wenn sowohl der Erst- als auch der Zweitbesitzer das Fahrrad online registriert haben. Die Originalrechnung ist für den Zweitbesitzer nicht erforderlich.

### Bitte registrieren Sie das Fahrrad zur Übertragung der Garantie.

#### Rahmenmaterial/Art der Nutzung

- Carbonfaser: 5 Jahre – Beschränkt\*
- Aluminium: 5 Jahre – Beschränkt\*
- Bitte beachten Sie die unten aufgeführten Beschränkungen

#### Weitere Garantie für Schäden durch Material- und Verarbeitungsfehler

- Beschichtung – Lackierung und Aufkleber: 1 Jahr
- Rahmenhardware, Federung, Gelenke und Buchsen: 1 Jahr
- \* Gelenke sind Teil des Rahmens.

[bikes.com/registration](https://bikes.com/registration)

## GARANTIEINFORMATIONEN

### HINWEIS

#### Garantie gilt nicht für Folgendes:

- Einbau und Verwendung von Komponenten, Teilen oder Zubehör, das ursprünglich nicht für das Fahrrad (oder den Rahmen) wie verkauft vorgesehen war oder nicht damit kompatibel ist
- Rocky Mountain Fahrrad wurde nicht von einem autorisierten Händler gekauft
- Rocky Mountain Fahrrad/Rahmen wurde im Internet durch Drittanbieter (z. B. eBay) erworben, unabhängig von den Angaben in der Auflistung
- Ausbleichen der Lackierung aufgrund von ultravioletter Licht (UV) oder Außenbewitterung fallen nicht unter diese beschränkte Garantie.
- Rocky Mountain übernimmt keine Garantie für Schäden am Fahrrad, die beim Anbringen oder Entfernen von Schutzfilmprodukten entstehen.
- Kratzer oder Steinschläge durch Schmutz, Steine, Fremdkörper, Transport auf Träger etc. fallen nicht unter diese beschränkte Garantie.
- Schäden am Pressfit-Tretlager durch unsachgemäßen Service, Materialien oder Teile sind von der beschränkten Rocky Mountain Garantie nicht abgedeckt.

#### Einzelheiten dazu, was nicht von der Garantie abgedeckt ist:

- a. Normale Abnutzung und Verschleiß an Reifen, Schläuchen, Bremsen, Schaltzügen, Bremsbelägen, Lagern etc. sind nicht abgedeckt. Ihr autorisierter Rocky Mountain Händler kann genaue Informationen über die Wartung dieser Teile geben.
- b. Schäden, die durch unsachgemäße Nutzung, Unfall, Fehlgebrauch oder Vorsatz entstanden sind
- c. Unsachgemäße Montage oder unterlassene ordnungsgemäße Wartung, Sandstrahlen, Schleifen, Fräsen, Bürsten, Feilen, Schweißen, Löten, das Bohren von Löchern, Eloxieren, Neulackieren oder Verchromen werden von unserer Garantie nicht abgedeckt und können dazu führen, dass die Garantie der anderen Komponenten erlischt.
- d. Neben dem hohen Risiko für Leib und Leben, kann die Herstellergarantie, wie in der Garantie-Tabelle aufgelistet, erlöschen, wenn unsere Produkte in extremem Gelände verwendet werden, wie es zum Teil in Mountainbike Videos gezeigt wird (wie zum Beispiel das Befahren extremer Trails, über Rampen springen, Stunts, BMX Trails befahren, in der Stadt über Treppen und andere Hindernisse fahren oder in ähnlichem Gelände fahren). Es sei darauf hingewiesen, dass verbogene Komponenten wie Rahmenteile, Gabeln, Lenker, Sattelstützen, Pedale, Speichen, etc. als Zeichen von Unfällen oder unsachgemäßer Nutzung angesehen werden können.
- e. Arbeitskosten für den Austausch oder den Wechsel von Teilen sind nicht eingeschlossen.
- f. Rocky Mountain Bicycles behält sich vor, Teile und Komponenten nach eigenem Ermessen als Garantiefall einzustufen und entsprechend zu reparieren oder zu ersetzen. Bitte beachten Sie, dass Rocky Mountain alle Anstrengungen unternimmt, jedoch eine Farbübereinstimmung mit dem ursprünglichen Teil nicht garantieren kann.

### GARANTIEAUSSCHLUSS UND HAFTUNGSBESCHRÄNKUNGEN

DIE GARANTIE VON ROCKY MOUNTAIN IST AUF DIE REPARATUR BZW. DEN AUSTAUSCH DER PRODUKTE BESCHRÄNKT UND SCHLIESST KEINE GARANTIE, WEDER AUSDRÜCKLICH NOCH IMPLIZIT, GESETZLICH ODER KONVENTIONELL EIN, UND SCHLIESST JEDGLICHE IMPLIZITE GEWÄHRLEISTUNG DER MARKTFÄHIGKEIT UND DER EIGNUNG FÜR BESTIMMTE ZWECKE AUS. ROCKY MOUNTAIN HAFTET UNTER KEINEN UMSTÄNDEN FÜR DIREKTE ODER INDIREKTE, BESTIMMTE, ZUFÄLLIGE ODER FOLGESCHÄDEN, SELBST WENN ROCKY MOUNTAIN ÜBER DIESE SCHÄDEN UNTERRICHTET WURDE. DIE HAFTUNGSSUMME VON ROCKY MOUNTAIN IST AUF 50,00 DOLLAR BESCHRÄNKT.

## KONFORMITÄTSERKLÄRUNG

Wir erklären, dass die folgenden mit Powerplay™ ausgestatteten Fahrradplattformen den einschlägigen Harmonisierungsvorschriften der Union entsprechen.

Rocky Mountain Instinct Powerplay SL™

Eine vollständige Liste der Modelle finden Sie unter [www.bikes.com](http://www.bikes.com)

Die oben beschriebenen Produkte erfüllen die Anforderungen folgender Richtlinien:

- Maschinenrichtlinie 2006/42/EG
- EMV-Richtlinie 2014/30/EU
- RoHS-Richtlinie 2011/65/EU

Die Produkte wurden so konzipiert und getestet, dass sie die Anforderungen der folgenden Normen erfüllen:

- EN15194:2017: Elektronisch unterstützte Fahrräder – EPAC-Fahrräder
- ISO4210-2:2015: Sicherheitsanforderungen und Prüfverfahren für Mountainbikes
- IEC/EN 62133-2:2017: Anforderungen und Tests für den sicheren Betrieb von tragbaren versiegelten sekundären Lithiumzellen und -batterien. Teil 2: Lithiumsysteme
- EN 50604-1:2016: Sekundäre Lithiumbatterien für leichte EV-Anwendungen (Elektrofahrzeuge) – Teil 1: Allgemeine Sicherheitsanforderungen und Prüfmethode

Ich, Pierre-Luc Lapointe, F&E-Direktor – Antrieb, bin damit beauftragt, die technischen Unterlagen im Namen des Herstellers Rocky Mountain, Division of Industries RAD Inc., zusammenzustellen.

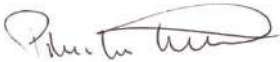

**Pierre-Luc Lapointe, ing.**  
**R&D Director – Propulsion**  
**9095 25th Avenue, St-George, Quebec, Canada**

**Authorized European representative:**



**Carsten Bresser**  
**Managing Director, Bikeaction GmbH**  
**Weiskircher Str. 102, Rodgau, Germany**

### Hersteller und EU-Importeur

Rocky Mountain  
 Division of Industries RAD inc.  
 9095, 25th Avenue  
 Saint-Georges, Qc,  
 Canada, G6A 1A1

### Autorisierter europäischer Vertreter

Bikeaction GmbH  
 Weiskircher Str. 102  
 63110 Rodgau  
 Deutschland

### Schweiz

CHRIS Sports AG  
 Wittenwilerstrasse 12,  
 8355 Aadorf  
 Schweiz

### Norwegen

Vertical Playground AS  
 Ola Setroms Veg 17  
 7340 Oppdal  
 Norwegen

**(EU) 2023/1542 ARTICLE 10 PART A OF ANNEX IV**

Model Name	Rated capacity and capacity fade		Power and power fade <small>*This value is for reference only.</small>				Internal resistance and internal resistance increase <small>*This value is for reference only.</small>		The expected life-time of the battery under the reference conditions for which is has been designed
	Rated capacity (Ah)	Capacity fade (%)	Power (W)		Power fade (%)		Internal resistance ( $\Omega$ )	Internal resistance increase (%)	Under the cycles (times)
			Power capability		Power capability				
			at 80%	at 20%	at 80%	at 20%			
<b>1972002</b>	14.3	>25	680	581	93	92	>0.143	195	1000
<b>1972011</b>	8.8	>50	676	581	96	95	>0.133	109	500
<b>1974005</b>	4.75	>25	383	328	91	89	>0.330	199	1000
<b>1975006</b>	9.5	>25	731	626	91	90	>0.162	196	1000

## AVVIO RAPIDO

### Collegare il Jumbotron

Per rispettare le norme di spedizione, la fonte di alimentazione deve essere scollegata durante il trasporto. Individuare e collegare la fonte di alimentazione principale (batteria) al motore.

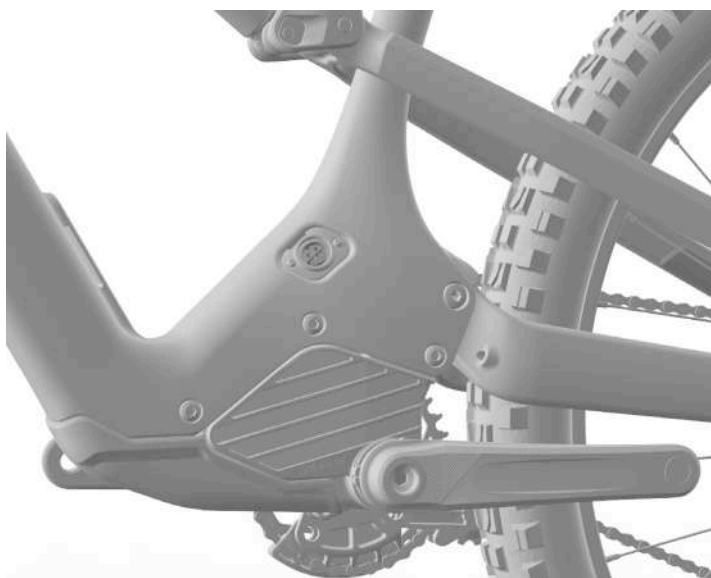

## AVVIO RAPIDO

### Ricarica della batteria

La batteria deve essere spedita con circa il 50% di carica. Carica la bicicletta prima del primo utilizzo. PRENDI NOTA DELL'ORIENTAMENTO DEL CONNETTORE. Il mancato allineamento del connettore può causare danni permanenti.



## AVVIO RAPIDO

### Accensione della bicicletta

Tieni premuto il pulsante di accensione del Jumbotron per 2 secondi per accendere la bicicletta.



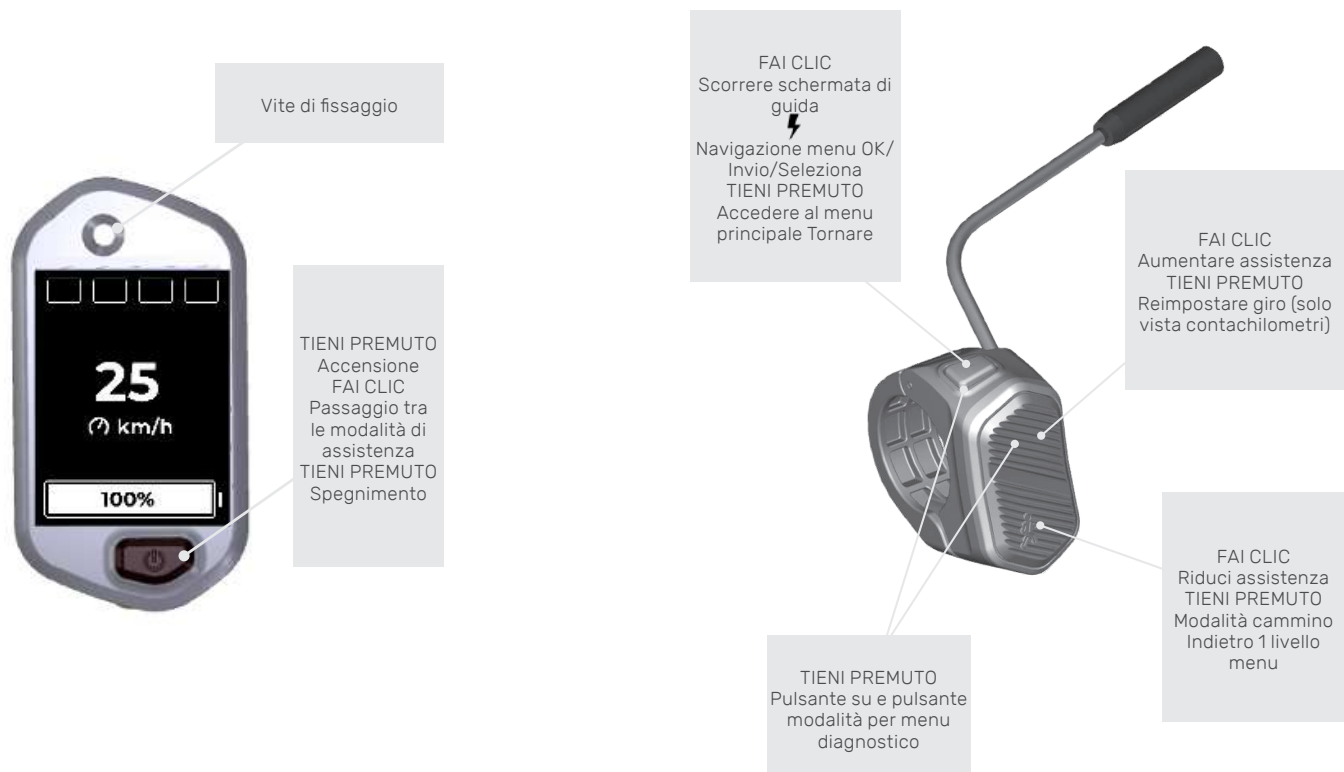

### Configurazione della bicicletta

Alla prima attivazione della bicicletta, verrà richiesto al ciclista di inizializzare le impostazioni. Questo passaggio può essere saltato e puoi iniziare subito a usare la tua bicicletta premendo ⚡. Per tornare al menu principale in qualsiasi momento, tieni premuto ⚡.



## AVVIO RAPIDO



### Come accedere al menu

Per accedere al menu principale in qualsiasi momento, tieni premuto . Per uscire, seleziona l'icona INDIETRO o tieni premuto .

### Come accedere alla diagnostica

Per accedere al menu diagnostico in qualsiasi momento, tieni premuto  insieme al pulsante di assistenza SU. Per uscire, seleziona l'icona INDIETRO o tieni premuto .

### Come navigare nel menu

Per navigare all'interno di un menu, usa i pulsanti di assistenza del telecomando SU e GIÙ; usa il pulsante  per confermare i comandi. Per uscire, seleziona l'icona INDIETRO o tieni premuto .

### Calibrazione prima dei 100 km

Il sistema di trasmissione Dyname S4 Lite utilizza la tensione della catena per misurare l'azione del ciclista. Quando una nuova trasmissione è sottoposta a rodaggio, è sempre raccomandato di calibrare il sistema dopo circa 75 km. Tieni premuto il pulsante  per accedere al menu principale, seleziona Calibrazione e segui le istruzioni.

## AVVERTIMENTO!

### MODALITÀ BAMBINO

Questa bici elettrica è dotata di un limitatore di potenza e di velocità, nonché di un blocco per bambini. Per ulteriori informazioni su come attivare e regolare queste impostazioni, consultare la sezione USO DELLA BICICLETTA di questo manuale.

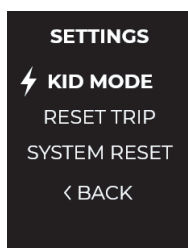

### Letture del manuale

Infine, cosa più importante, leggi il resto del manuale o consultalo online all'indirizzo [support.bikes.com](http://support.bikes.com).

## INTRODUZIONE

Il vostro istinto, elettrificato. L'Instinct Powerplay™ SL racchiude una grande potenza in un pacchetto leggero. Grazie al nuovo sistema di trasmissione Dyname S4 Lite, abbiamo progettato una bici che si guida come una trail bike, ma con la potenza necessaria per esplorare più a fondo che mai. Costruito attorno al nostro sistema di sospensioni a perno medio-alto, il telaio è stato completamente rivisto con una geometria e una cinematica delle sospensioni aggiornate, migliorando la sensazione di guida e offrendo numerose regolazioni del telaio.

Questo manuale contiene importanti informazioni sulla sicurezza, la manutenzione e l'utilizzo. Assicuratevi di leggerlo attentamente e di comprenderlo a fondo prima della prima uscita con la vostra nuova bicicletta Rocky Mountain Instinct Powerplay™ SL. Questo materiale si applica solo alla piattaforma specifica scelta e deve essere utilizzato insieme al Manuale d'uso Rocky Mountain, incluso nella bicicletta. Leggere il Manuale d'uso prima della prima uscita. Se non si dispone di una copia del Manuale d'uso, è possibile ottenerlo presso il rivenditore autorizzato Rocky Mountain più vicino o online, sulla pagina del prodotto del modello di bicicletta.

## SHREDIQUETTE

### Utenti

Sii sempre educato con chi si trova sugli stessi sentieri. Presta particolare attenzione agli animali domestici, come cani e cavalli. Dai sempre la precedenza agli altri passanti, sia in salita che in discesa.

I modelli Instinct Powerplay SL™ sono progettati per la guida trail in aree approvate. Ne è previsto l'uso su terreni più difficili che includono salti moderati e caratteristiche tecniche. Questi modelli non sono progettati per utilizzi estremi, con salti eccessivi o discese su percorsi accidentati a velocità superiori a 40 km/h, o una loro combinazione: ciclismo hardcore dirt jumping, freeride, downhill, sentieri e terreni di tipo North Shore. Questi modelli non sono adatti a precipizi, salti, lanci da strutture in legno o altre acrobazie che prevedono atterraggi su terreno duro e ostacoli rigidi.

### Sentieri

Utilizza la tua bicicletta Powerplay™ solo su sentieri dove è consentito il passaggio di veicoli a motore. Rispetta tutte le leggi e le normative locali. Come tutti gli utenti dei sentieri, anche i ciclisti devono prestare attenzione a evitare impatti sul sentiero o sull'ambiente. Non sbandare sui sentieri e non modificarli.

### Strade pubbliche

Prima di utilizzare il tuo modello Rocky Mountain Instinct Powerplay SL, informati su tutti i requisiti legali e i regolamenti applicabili nel tuo paese e nella tua zona. Potrebbero esserci restrizioni all'utilizzo della tua bicicletta Powerplay™ su sentieri, piste ciclabili o strade pubbliche. Potrebbero esserci anche norme sull'utilizzo del casco e delle luci, limitazioni di età o requisiti di patente o assicurazione. Rocky Mountain non rilascia né rilascerà alcuna promessa, dichiarazione o garanzia riguardo all'uso della tua bicicletta Powerplay™. Poiché le leggi e i regolamenti riguardanti le biciclette elettriche variano a seconda del paese e della zona e sono in continua evoluzione, assicurati di ottenere informazioni aggiornate. Rivolgiti inoltre regolarmente al tuo rivenditore autorizzato Rocky Mountain Bicycles per informazioni aggiornate.

### Visibilità e Sicurezza

Prima di utilizzare la tua bicicletta Rocky Mountain Powerplay, assicurati che tutti i dispositivi di visibilità e sicurezza inclusi con la tua bicicletta Powerplay siano installati su di essa per garantire il rispetto degli obblighi legali o delle norme in vigore nel tuo Paese, Stato o provincia.

Se con la tua bicicletta Rocky Mountain Powerplay è incluso un campanello (Francia, Regno Unito, Australia e Nuova Zelanda), è obbligatorio installarlo sulla bicicletta Powerplay prima dell'uso.

## AVVERTIMENTI

### Potenza

La bicicletta Powerplay™ è dotata di una potente funzionalità di pedalata assistita quando si esercita forza sui pedali. Prendi confidenza con le caratteristiche di guida e di pedalata assistita della tua bicicletta su un giro sicuro e piano prima di usarla sui percorsi fuoristrada.

### Avviamento istantaneo

La bicicletta Powerplay™ è dotata della tecnologia "Avviamento istantaneo", che usa un sofisticato circuito di rilevazione della coppia per erogare istantaneamente una potenza uniforme e naturale. Tale circuito è molto sensibile e quindi è necessario prestare attenzione a evitare che la bicicletta acceleri da ferma in modo inatteso o incontrollato.

### Prestare attenzione ai sui sentieri

La bicicletta Powerplay™ accelera più rapidamente e si comporta diversamente rispetto alle biciclette tradizionali non assistite. Occorre prestare un'attenzione adeguata sui sentieri e tenere a mente le particolari caratteristiche di comportamento e accelerazione della bicicletta.

### Mantenere lontane le dita

Non avvicinare le dita o qualsiasi attrezzo all'unità di trasmissione. La manutenzione e la riparazione dell'unità di trasmissione devono essere eseguite esclusivamente da un centro di assistenza autorizzato Rocky Mountain.



### Non modificare

Non modificare l'unità di trasmissione Powerplay o qualsiasi componente collegato direttamente all'unità di trasmissione. La manutenzione e la riparazione dell'unità di trasmissione devono essere eseguite esclusivamente da un centro di assistenza autorizzato Rocky Mountain. Qualsiasi tentativo di modificare l'unità di trasmissione Powerplay può causare gravi lesioni personali o la morte e invalida immediatamente la garanzia della bicicletta.

## AVVERTIMENTI

Non agganciare un portabebè, un rimorchio o un accessorio simile a una parte o componente in materiale composito o in fibra di carbonio, direttamente o indirettamente. Ad esempio, non fissare un rimorchio a un asse posteriore quando il triangolo posteriore è fatto di materiale composito o di fibra di carbonio. Analogamente, non agganciare un rimorchio a un reggisella in materiale composito o in carbonio o un portabebè a una forcella in composito o in carbonio. Entrambi potrebbero applicare sul telaio o sul componente della bicicletta forze inusuali che potrebbero provocare danni e causare un guasto totale, con il rischio di lesioni gravi o fatali. Se hai già fissato in precedenza un accessorio a una parte o un componente in materiale composito o in carbonio, non usare la bicicletta finché il tuo rivenditore autorizzato Rocky Mountain non avrà condotto un'attenta ispezione di sicurezza. Prima di trasportare bambini sulla bicicletta, informati su tutti i requisiti legali e i regolamenti applicabili nel tuo paese e nella tua zona. Potrebbero esserci delle restrizioni all'uso della bicicletta con determinati accessori. Ciò vale in particolare per le biciclette elettriche e a pedalata assistita.

### Avviso 1

Come tutti i componenti meccanici, il componente EPAC è sottoposto a usura e a forti sollecitazioni. Materiali e componenti diversi possono reagire all'usura o alla fatica da stress in modi diversi. Se si supera la durata di vita prevista di un componente, questo può improvvisamente cedere e causare lesioni al ciclista. Qualsiasi incrinatura, graffio o cambiamento di colore in aree sottoposte a forti sollecitazioni indica che la vita del componente è stata raggiunta e che è necessaria la sua sostituzione.

### Avviso 2

Per i componenti in materiale composito, i danni da impatto possono essere invisibili all'utente; il produttore deve spiegare le conseguenze dei danni da impatto e che, in caso di impatto, i componenti in materiale composito devono essere restituiti al produttore per un'ispezione, oppure distrutti e sostituiti.

### Avviso 3

Non esporre la bicicletta per periodi prolungati alla luce solare diretta o a un calore eccessivo, come all'interno di un'auto parcheggiata o vicino a una fonte di calore come un radiatore. Il calore eccessivo può degradare le proprietà dei materiali di componenti e parti come batterie, parti come manubri, pedivelle e altri elementi realizzati in materiali compositi, nonché di vari componenti in plastica che contribuiscono all'integrità complessiva della bicicletta.

### Avviso 4

Il carico utile totale massimo consentito (ciclista più bagagli e peso a vuoto dell'EPAC) è di 130 kg per la Instinct Powerplay SL in carbonio e di 140 kg per la versione in alluminio.

### Avviso 5

Il mancato rispetto delle avvertenze contenute in questa sezione può provocare danni ai componenti della bicicletta e invalidare la garanzia ma, soprattutto, può provocare lesioni personali gravi o fatali. Se la bicicletta mostra segni di danni, non la utilizzare ma portala immediatamente al tuo rivenditore Rocky Mountain Bicycles per un controllo.

### Avviso 6

In caso di incidente o di montaggio non corretto, il manubrio e i comandi sul manubrio possono essere compromessi, con effetti negativi sulla sicurezza della risposta alle azioni di sterzo e frenata.

### Avviso 7

Non gonfiare mai uno pneumatico oltre il valore di pressione massima più basso tra quello indicato sul lato dello pneumatico e quello indicato sul cerchione dove è montato lo pneumatico. Il superamento della pressione massima consigliata può far fuoriuscire lo pneumatico dal cerchione, con possibilità di danni alla bicicletta e lesioni per il ciclista e le persone nelle immediate vicinanze.

## CONOSCERE LA TUA BICICLETTA



### DETTAGLI TECNICI

- L'Instinct Powerplay™ SL è Costruita attorno al nostro nuovissimo sistema di trasmissione Dyname S4 Lite. Caratterizzato da un design del telaio completamente nuovo, Con nuovi profili dei tubi, il telaio dell'Instinct Powerplay SL è più leggero e offre maggiori possibilità di regolazione rispetto al suo predecessore, per adattarsi meglio ad ogni persona.
- La nuova unità Dyname S4 Lite vi farà sfrecciare sulle salite con una coppia di picco fino a 65 Nm e una potenza di picco fino a 550 watt. A una cadenza di 80 RPM, il motore può offrire fino a 500 Watt di potenza, ogni volta che ne avete bisogno.
- Costruito attorno al nostro sensore di coppia esterno brevettato, il sistema Dyname S4 Lite legge la tensione applicata direttamente alla catena ed elimina il tempo di ritardo indesiderato per dare una risposta istantanea e naturale quando viene applicata la potenza. Dotato della nuova batteria da 480 Wh, leggera e sottile, il nuovo sistema Dyname S4 Lite offre oltre il 90% dell'autonomia e della verticalità del sistema Dyname 4.0 (test effettuati in modalità Ludicrous, Boost +2).
- Dyname S4 Lite è dotato di un display Jumbotron, perfettamente integrato nel tubo superiore, che mostra tutti i dati e le informazioni principali in una posizione comoda e facile da vedere. Le schermate possono essere navigate utilizzando il telecomando del manubrio o i pulsanti del Jumbotron stesso.
- Il cinematismo Mid-High Pivot rivisitato è caratterizzato da una sensibilità abbinata a un maggiore sostegno lungo tutta l'escursione, con l'obiettivo di aumentare il sostegno e il comfort nelle corse brevi e lunghe.
- Disponibile in un'ampia gamma di misure di telaio e ruote. Il telaio XS è dotato di ruote anteriori e posteriori da 27,5". I telai SM-MD-LG-XL sono dotati di ruote anteriori e posteriori da 29". Queste misure sono anche compatibili con il mullet con l'uso di un leveraggio specifico per sospensioni MX.
- Il sistema di regolazione RIDE-4™ consente ai ciclisti di mettere a punto rapidamente la geometria con una sola chiave a brugola.
- Tutti i telai sono dotati di serie sterzo con regolazione del reach per regolare con precisione il reach. Sul telaio è installata una serie sterzo neutra da 0 mm. Nella scatola di minuteria che accompagna ogni telaio e ogni bicicletta completa, c'è un set aggiuntivo di tappi da 5 mm per la serie sterzo che possono essere utilizzati per la regolazione del reach.
- I cuscinetti sigillati all'occhiello dell'ammortizzatore migliorano drasticamente la sensibilità dell'ammortizzatore (compatibile con gli ammortizzatori aftermarket), mentre gli schermi dei cuscinetti su tutto il telaio aiutano a prevenire la contaminazione da parte di sentieri accidentati o stazioni di lavaggio post corsa.
- Le nostre sospensioni Smoothlink sono dotate di cuscinetti satndar e di facile manutenzione, abbinati a un design resistente dei perni.
- Il passaggio interno completamente chiuso dei nostri modelli in carbonio e in lega, grazie al manicotto guida cavi integrato, consente una facile installazione di cavi e tubi, comprese le configurazioni dei freni in stile moto.
- I telai sono dotati di un'ampia protezione in gomma per ridurre il rumore e prevenire l'abrasione da contatto.

## GEOMETRIA E DIMENSIONI

L'Instinct Powerplay™ SL è un telaio specifico per la taglia che presenta numerosi dettagli che migliorano la vestibilità e la geometria per ogni ciclista.

### Dimensioni della ruota

- Il telaio XS è dotato di ruote da 27,5" davanti e dietro.
- Il telaio XS non è compatibile con le ruote da 29" o MX.
- I modelli SM, MD, LG e XL sono dotati di ruote da 29" davanti e dietro.
- SM, MD, LG e XL sono compatibili con mullet/MX sostituendo il leveraggio della sospensione.

### Serie sterzo con regolazione del reach

Tutti i telai sono dotati di serie sterzo con regolazione precisa del reach. Sul telaio è installata una serie sterzo neutra da 0 mm. Nella scatola delle minuterie in dotazione con ogni telaio e bicicletta completa c'è un set aggiuntivo di coppe della serie sterzo da 5 mm che possono essere utilizzate per regolare il reach. Quando consulti la tabella delle geometrie con le coppe per offset da 5 mm installate, ti basta aggiungere o sottrarre 5 mm dalle misure reach, lunghezza tubo orizzontale e interasse, in base all'orientamento delle coppe. Per le istruzioni sull'installazione, consulta la sezione sulle caratteristiche del telaio.

Serie sterzo in carbonio 0 mm



Serie sterzo in carbonio 5 mm



Serie sterzo in lega 0 mm



Serie sterzo in lega 5 mm



### Dimensioni del telaio

This chart is a rough guide only. Rider proportions, riding style, and personal preferences all factor in choosing the correct bike size. Generally, shorter reach bikes tend to have a more dynamic, lively feel. Longer bikes tend to have a more stable, muted feel. Rocky Mountain always recommends test riding and professional bike fitting at an authorized dealer.

CM	147.5	150	152.5	152.5	155	157.5	160	162.5	165	167.5	170	172.5	175	177.5	180	183	185.5	188	190.5	193	195.5	198
FT-IN	4'7"	4'8"	4'9"	5'0"	5'1"	5'2"	5'3"	5'4"	5'5"	5'6"	5'7"	5'8"	5'9"	5'10"	5'11"	6'	6'1"	6'2"	6'3"	6'4"	6'5"	6'6"
	XS			SM			MD			LG			XL									
XS	[Red bar]																					
SM	[Red bar]																					
MD	[Red bar]																					
LG	[Red bar]																					
XL	[Red bar]																					

## GEOMETRIA E DIMENSIONI

### RIDE-4 Adjustment

Il sistema di regolazione RIDE-4™ consente ai ciclisti di mettere a punto rapidamente la geometria con una sola chiave a brugola da 5 mm. Sono possibili quattro configurazioni grazie a una coppia di chip rotanti. Per sapere come ogni posizione influisce sulla geometria, consultare la tabella delle geometrie. Per le istruzioni di regolazione, consultare la sezione Caratteristiche del telaio.

**PRONTO PER QUALSIASI PERCORSO**

Il sistema di regolazione RIDE-4™ consente di regolare rapidamente la geometria e le sospensioni con una sola chiave a brugola da 5 mm.

PIÙ RIPIDO ANGOLO TESTA-TUBO

SOSPENSIONE MENO PROGRESSIVA

SLACKER ANGOLO DEL TUBO DI STERZO

SOSPENSIONI PIÙ PROGRESSIVE



#### Position 1



Il movimento centrale più basso e le sospensioni progressive aumentano la stabilità alle alte velocità. Consigliata per i trail più aggressivi

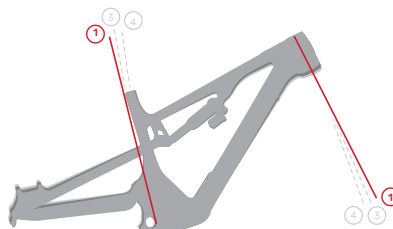

#### Position 3



Questa posizione offre una miscela equilibrata di geometria e prestazioni delle sospensioni per soddisfare un'ampia varietà di percorsi.

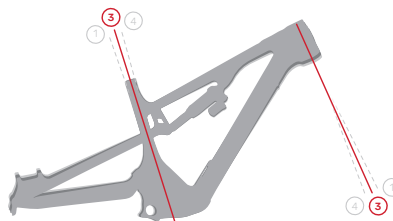

#### Position 4



Il movimento centrale più alto e la sospensione lineare consentono un migliore spazio per i pedali, un tasso di sospensione iniziale più sostenuto e una posizione sulla bicicletta più adatta alla salita.

## GEOMETRIA E DIMENSIONAMENTO

MISURA TELAIO		XS	SM	MD	LG	XL
DIMENSIONI RUOTE		27.5		29		
Angolo canotto di sterzo (gradi)		63.5	63.5	63.5	63.5	63.5
Angolo tubo piantone (gradi)		76.4	77.0	76.5	76.5	76.5
Lunghezza tubo piantone (mm)		355.0	365.0	410.0	440.0	470.0
Lunghezza tubo orizzontale (mm)		542.0	567.0	599.0	627.0	659.0
Lunghezza canotto di sterzo (mm)		105.0	105.0	110.0	125.0	135.0
Interasse posteriore (mm)	Position 1 - Slack	433.0	442.0	442.0	452.0	452.0
Drop movimento centrale (mm)		24.2	38.8	38.8	38.7	38.8
Altezza standover (mm)		775.0	785.0	809.0	808.0	807.0
Interasse (mm)		1157.0	1205.0	1232.0	1274.0	1308.0
Reach (mm)		399.0	425.0	450.0	475.0	505.0
Stack (mm)		590.0	618.0	622.0	636.0	645.0
Angolo canotto di sterzo (gradi)		63.7	63.7	63.7	63.7	63.7
Angolo tubo piantone (gradi)		76.6	77.2	76.7	76.7	76.7
Lunghezza tubo piantone (mm)		355.0	365.0	410.0	440.0	470.0
Lunghezza tubo orizzontale (mm)		541.0	567.0	599.0	627.0	659.0
Lunghezza canotto di sterzo (mm)		105.0	105.0	110.0	125.0	135.0
Interasse posteriore (mm)	Position 2	430.0	440.0	440.0	450.0	450.0
Drop movimento centrale (mm)		17.0	32.0	32.0	32.0	32.0
Altezza standover (mm)		780.0	790.0	813.0	813.0	813.0
Interasse (mm)		1154.0	1203.0	1230.0	1272.0	1306.0
Reach (mm)		405.0	430.0	455.0	480.0	510.0
Stack (mm)		586.0	614.0	618.0	632.0	641.0

## GEOMETRIA E DIMENSIONAMENTO

MISURA TELAIO		XS	SM	MD	LG	XL
DIMENSIONI RUOTE		27.5		29		
Angolo canotto di sterzo (gradi)		64.0	64.0	64.0	64.0	64.0
Angolo tubo piantone (gradi)		77.0	77.5	77.0	77.0	77.0
Lunghezza tubo piantone (mm)		355.0	365.0	410.0	440.0	470.0
Lunghezza tubo orizzontale (mm)		540.0	566.0	598.0	626.0	658.0
Lunghezza canotto di sterzo (mm)		105.0	105.0	110.0	125.0	135.0
Interasse posteriore (mm)	Position 3 - Neutral	430.0	440.0	440.0	450.0	450.0
Drop movimento centrale (mm)		17.0	32.0	32.0	32.0	32.0
Altezza standover (mm)		780.0	790.0	813.0	813.0	813.0
Interasse (mm)		1154.0	1203.0	1230.0	1272.0	1306.0
Reach (mm)		405.0	430.0	455.0	480.0	510.0
Stack (mm)		586.0	614.0	618.0	632.0	641.0
<hr/>						
Angolo canotto di sterzo (gradi)		64.2	64.2	64.2	64.2	64.2
Angolo tubo piantone (gradi)		77.2	77.7	77.2	77.2	77.2
Lunghezza tubo piantone (mm)		355.0	365.0	410.0	440.0	470.0
Lunghezza tubo orizzontale (mm)		540.0	566.0	597.0	625.0	657.0
Lunghezza canotto di sterzo (mm)		105.0	105.0	110.0	125.0	135.0
Interasse posteriore (mm)	Position 3 - Neutral	429.0	439.0	439.0	449.0	449.0
Drop movimento centrale (mm)		14.1	29.2	29.1	29.1	29.0
Altezza standover (mm)		782.0	792.0	816.0	815.0	815.0
Interasse (mm)		1153.0	1202.0	1229.0	1271.0	1305.0
Reach (mm)		407.0	432.0	457.0	482.0	512.0
Stack (mm)		585.0	612.0	617.0	630.0	639.0

## MONTAGGIO DEL REGGISELLA TELESCOPICO

I reggisella telescopici svolgono un ruolo importante per l'adattamento e il comfort della bicicletta. Di seguito troverai le dimensioni e le misure fondamentali che ti guideranno nella configurazione del reggisella OEM, oltre ad alcune delle possibili opzioni in caso di installazione di un reggisella telescopico post-vendita. La tabella mostra il montaggio del reggisella con l'escursione completamente estesa, consentendoti di determinare la posizione più bassa o più alta in cui il reggisella può essere regolato per ottenere l'altezza corretta in una posizione di pedalata da seduti. La tabella ti aiuta anche a determinare la misura del reggisella da installare se quello OEM non è della misura desiderata. La dimensione indicata è misurata dal centro del movimento centrale alla parte superiore della sella OEM. La lunghezza del set pedivelle può influenzare l'adattamento della seduta e deve essere presa in considerazione se si cambia questo componente.

Come usare la tabella

1. Misura l'attuale altezza della sella dal centro del movimento centrale alla parte superiore della sella, proprio sopra il reggisella.
2. Scegli il modello del reggisella, l'escursione/drop e il telaio.
3. Assicurati che la tua misura sia compresa tra la lunghezza di inserimento minima e massima indicate nella tabella.

Esempio: la mia misura sulla mia bici attuale è di 795 mm. Se scelgo un modello OneUp V3, con escursione di 210 mm, su un telaio LG in carbonio, vedo che questa combinazione di escursione del reggisella e misura del telaio è adatta a me, dato che le misure minime e massime possibili sono 725 mm e 855 mm.

POST MODEL	POST TRAVEL	FRAME SIZE	CARBON					ALLOY				
			XS	SM	MD	LG	XL	XS	SM	MD	LG	XL
		Seat Tube Length	355	365	410	440	470	355	365	410	440	470
		Minimum Insertion	100	100	100	100	100	100	100	100	100	100
		Maximum Insertion	220	230	275	305	335	220	230	275	305	335
<b>X Fusion Manic</b>	125	Minimum saddle height	541	547	592	622	652	541	547	592	622	652
	125	Maximum saddle height	623	633	678	708	738	623	633	678	708	738
	150	Minimum saddle height	605	605	617	647	677	605	605	617	647	677
	150	Maximum saddle height	687	697	742	772	802	687	697	742	772	802
	170	Minimum saddle height	649	649	649	667	697	649	649	649	667	697
	170	Maximum saddle height	701	711	756	786	816	701	711	756	786	816
	190	Minimum saddle height	702	702	702	702	717	702	702	702	702	717
	190	Maximum saddle height	734	744	789	819	849	734	744	789	819	849
<b>2025 Fox Transfer</b>	120	Minimum saddle height	556	566	611	641	671	556	566	611	641	671
	120	Maximum saddle height	646	656	701	731	761	646	656	701	731	761
	150	Minimum saddle height	619	619	642	672	702	619	619	642	672	702
	150	Maximum saddle height	711	721	766	796	826	711	721	766	796	826
	180	Minimum saddle height	684	684	684	701	731	684	684	684	701	731
	180	Maximum saddle height	776	786	831	861	891	776	786	831	861	891
	210	Minimum saddle height	749	749	749	749	761	749	749	749	749	761
	210	Maximum saddle height	841	851	896	926	956	841	851	896	926	956
	240	Minimum saddle height	819	819	819	819	819	819	819	819	819	819
	240	Maximum saddle height	911	921	966	996	1026	911	921	966	996	1026

POST MODEL	POST TRAVEL	FRAME SIZE	CARBON					ALLOY				
			XS	SM	MD	LG	XL	XS	SM	MD	LG	XL
<b>2020-2024 Race Face Turbine R Fox Transfer</b>	125	Minimum saddle height	572	573	618	648	678	572	573	618	648	678
	125	Maximum saddle height	664	674	719	749	779	664	674	719	749	779
	150	Minimum saddle height	626	626	643	673	703	626	626	643	673	703
	150	Maximum saddle height	718	728	773	803	833	718	728	773	803	833
	175	Minimum saddle height	683	683	683	698	728	683	683	683	698	728
	175	Minimum saddle height	775	785	830	860	890	775	785	830	860	890
	200	Minimum saddle height	739	739	739	739	754	739	739	739	739	754
	200	Maximum saddle height	781	791	836	866	896	781	791	836	866	896
<b>OneUp V3 Dropper</b> *Travel can be reduced by up to 20mm, in 10 mm increments.	120	Seat Tube Length	550	560	605	635	665	550	560	605	635	665
	120	Minimum Insertion	650	660	705	735	765	650	660	705	735	765
	150	Maximum Insertion	595	595	635	665	695	595	595	635	665	695
	150	Minimum saddle height	700	710	755	785	815	700	710	755	785	815
	180	Maximum saddle height	660	660	665	695	725	660	660	665	695	725
	180	Minimum saddle height	750	760	805	835	865	750	760	805	835	865
	210	Maximum saddle height	725	725	725	725	755	725	725	725	725	755
	210	Minimum saddle height	800	810	855	885	915	800	810	855	885	915
	240	Maximum saddle height	790	790	790	790	790	790	790	790	790	790
240	Minimum saddle height	850	860	905	935	965	850	860	905	935	965	
<b>Reverb AXS</b> *Min post insertion is 80mm, however frame requires 100mm	125	Minimum saddle height	593	600	645	675	705	593	600	645	675	705
	125	Maximum saddle height	710	720	765	795	825	710	720	765	795	825
	150	Minimum saddle height	643	643	670	700	730	643	643	670	700	730
	150	Maximum saddle height	760	770	815	845	875	760	770	815	845	875
	170	Minimum saddle height	683	683	690	720	750	683	683	690	720	750
170	Maximum saddle height	800	810	855	885	915	800	810	855	885	915	

## SPECIFICHE E DIMENSIONI

### Serie sterzo con regolazione del reach

Tutti i telai sono dotati di serie sterzo con regolazione precisa del reach. Sul telaio è installata una serie sterzo neutra da 0 mm. Nella scatola delle minuterie in dotazione con ogni telaio e bicicletta completa c'è un set aggiuntivo di coppe della serie sterzo da 5 mm che possono essere utilizzate per regolare il reach.

Il telaio Carbon Instinct Powerplay™ SL utilizza calotte ovali di tipo drop-in. Non sono necessari attrezzi per rimuovere e installare le coppe nel telaio. Le coppe sono allineate automaticamente grazie alla forma ovale combaciante delle coppe e del canotto di sterzo. Le coppe sono dotate di un anello integrato al loro esterno che le mantiene fissate al telaio e riduce i movimenti potenzialmente rumorosi. Il modello delle serie sterzo dei telai in carbonio è il n. 85-1, prodotto da FSA. Utilizza parti di assemblaggio standard di FSA, come i cuscinetti e i race, per garantire che la sostituzione delle parti soggette a usura avvenga senza problemi.

Il telaio Alloy Instinct Powerplay™ SL utilizza coppe della serie sterzo sovradimensionate da inserire con pressione. Per rimuovere e installare le coppe nel telaio sono necessari attrezzi specializzati per l'installazione della serie sterzo. L'allineamento non è guidato dalla forma delle coppe e del canotto di sterzo e pertanto deve essere gestito con attenzione per essere portato a termine correttamente. Le coppe presentano un segno sul lato esterno per l'allineamento al telaio. Il modo più semplice per assicurarsi che l'allineamento delle coppe sia corretto è allineare un righello dal bordo dritto lungo questo segno e la lunghezza del tubo orizzontale (coppa superiore) o del tubo obliquo (coppa inferiore). Il modello delle serie sterzo dei telai in lega è HS-RM-01, prodotto da FSA. Utilizza parti di assemblaggio standard di FSA, come i cuscinetti e i race, per garantire che la sostituzione delle parti soggette a usura avvenga senza problemi.

### Montaggio della cuffia Instinct Powerplay SL Carbon

QTÀ	ELEMENTO	CODICE SERIALE	DESCRIZIONE
N/A	Serie sterzo	14100078000013	Numero di parte FSA   No.85-1 0mm Offset Headset, completo
N/A	Serie sterzo	1194001	RMB Numero di parte   No.85-1 0mm Cuffia offset, completa
1	Set coppe serie sterzo	141-0079000011	Numero di parte FSA   No.85-1 Solo calotte offset da 5 mm
1	Set coppe serie sterzo	1194002	Numero di parte RMB   No.85-1 Coppe offset da 5 mm incl. O-ring
1	Anello in gomma	160-7042	FSA Top Cap O-Ring interno in gomma
1	Tappo superiore	161-4430	FSA 5,3 mm Top Cap con guarnizione in gomma
1	Race diviso	160-7626	Anello di compressione della serie sterzo FSA da 1 1/8
1	Cuscinetto	160-6465	FSA Stainless ACB 1 1/8" 36°x45° Cuscinetto
1	Cuscinetto	160-67400E	FSA Stainless ACB 1,5" 36°x45° Cuscinetto
1	Gara della corona	160-5536	Corona da 1,5" FSA

### Montaggio della cuffia in lega Instinct Powerplay SL

QTÀ	ELEMENTO	CODICE SERIALE	DESCRIZIONE
N/A	Serie sterzo	1194003	RMB ZS56 66 0mm Cuffia con offset, completa
N/A	Set coppe serie sterzo	1194004	RMB Upper ZS56   Set di tazze offset da 5 mm
1	Anello in gomma	160-7042	O-Ring interno in gomma del tappo superiore
1	Tappo superiore	161-4430	Tappo superiore FSA da 5,3 mm con guarnizione in gomma
1	Race diviso	160-7626	Anello di compressione della serie sterzo FSA da 1 1/8
1	Cuscinetto	160-6465	FSA Stainless ACB 1 1/8" 36°x45° Cuscinetto
1	Cuscinetto	160-67400E	FSA Stainless ACB 1,5" 36°x45° Cuscinetto
1	Gara della corona	160-5536	Corona da 1,5" FSA

## SHOCK BEARING EYELET AND HARDWARE

Il telaio è dotato di cuscinetti a cartuccia nell'occhiello posteriore, che consentono una migliore aderenza ai piccoli urti. Questi cuscinetti sono sostenuti da coppe che si inseriscono a pressione nello stelo dell'ammortizzatore. In caso di manutenzione dell'ammortizzatore, consigliamo vivamente di rimuovere questi componenti, poiché i centri di assistenza per le sospensioni non possono garantirne la restituzione.

L'hardware dell'ammortizzatore anteriore è un kit standard fornito dal produttore dell'ammortizzatore. Per informazioni tecniche su tutta la viteria dell'ammortizzatore, diagrammi di riferimento e istruzioni per la rimozione del sistema di occhielli dei cuscinetti, consultare la tabella sottostante.



**Montaggio** Occhiello del cuscinetto dell'ammortizzatore posteriore Instinct Powerplay SL

**Dimensioni** 40 x 8 mm (larghezza x diametro della ferramenta)

NUMERO ELEMENTO	QTÀ	ELEMENTO	CODICE SERIALE	DESCRIZIONE
N/A	1	KIT OCCHIELLO CUSCINETTO AMMORTIZZATORE	1811007	Kit di occhielli per cuscinetti ammortizzatori da 8 x 40 mm
6	2	Cuscinetto	1801010	ENDURO 688 LLU MAX 16X8X5
17	2	Coppa del cuscinetto	1800031	OCCHIELLO PER CUSCINETTO PER 16X8X5 BRG
71	1	Manicotto	1807028	CUSCINETTO OCCHIELLO MANICOTTO CENTRALE
18	2	Distanziale per cuscinetti	1800032	DISTANZIALE PER CUSCINETTI A OCCHIELLO, T:6,3, PER LARGHEZZA MAGLIA 40 MM

**Montaggio** Hardware dell'ammortizzatore anteriore Instinct Powerplay SL

**Dimensioni** 25 x 8 mm (larghezza del perno di shock x diametro dell'hardware)

NUMERO ELEMENTO	QTÀ	ELEMENTO	CODICE SERIALE	DESCRIZIONE
N/A	1	Fox Kit completo	803-03-328	Hardware di montaggio FOX - 9 pezzi AL 8 mm x 25 mm/0,984
N/A	1	RockShox Kit completo	11.4118.091.816	RockShox, Hardware ammortizzatore, 8 X 25,0 mm

Suggerimento professionale: Il kit completo Fox è compatibile con gli occhielli degli ammortizzatori Rock Shox. Rimuovere la boccia in teflon dall'occhiello Rock Shox prima di installare il kit Fox.

## OCCHIELLO E MINUTERIA CUSCINETTI AMMORTIZZATORE

### Rimozione dell'occhiello del cuscinetto

#### Per rimuovere il sistema, segui questi passaggi:

- Utilizzare il kit di utensili per occhielli ammortizzatori Rocky Mountain (codice# 1810031)
- Installare la calotta copri cuscinetto su un lato dell'occhiello del cuscinetto
- Quindi, installare uno degli strumenti per la rimozione della coppa sopra la coppa del cuscinetto con la calotta copri cuscinetto installato.
- Avvitare saldamente la vite M8 contro la calotta copri cuscinetto
- Installare l'altro strumento di rimozione della coppa sopra l'altra coppa del cuscinetto
- Avvitare la vite M8 fino in fondo fino a quando non inizia a spingere sull'altro lato. È a contatto con l'interno della calotta copri cuscinetto.
- Continuare a infilare fino a quando una delle coppe non è completamente estratta.
- Quindi inserire il punteruolo attraverso l'occhiello dell'ammortizzatore e appoggiarlo saldamente contro la coppa del cuscinetto che è ancora premuta nell'occhiello dell'ammortizzatore.

- Delicatamente, ma con fermezza, martellare il punteruolo fino a rimuovere completamente la coppa del cuscinetto dall'occhiello dell'ammortizzatore.

#### Se non si dispone del kit di strumenti per occhielli per cuscinetti Rocky Mountain, utilizzare un estrattore per cuscinetti a foro cieco:

- Utilizzare un estrattore per cuscinetti a foro cieco (estensione di 8mm) per rimuovere entrambi i cuscinetti.
- Rimuovere la boccola centrale.
- Utilizzare l'estrattore per cuscinetti a foro cieco (estensione da 10mm) per rimuovere le coppe vuote.

*NOTA: il diametro interno delle coppe è di 11 mm, il che significa che l'estensione da 12mm non si adatta (quindi non forzarla); utilizzare l'estensione da 10mm.*

Per installare nuove coppe, utilizzare una pressa per cuscinetti o una morsa con ganasce morbide installate, assicurandosi di premere sul bordo esterno delle coppe e non dimenticare la boccola distanziatrice centrale tra le coppe.

## CONFIGURAZIONE DELLE SOSPENSIONI

Prima di cambiare le impostazioni degli ammortizzatori, è importante informarsi sulle varie regolazioni possibili.

### Regolazione della molla

A seconda del modello di ammortizzatore, potrebbe essere necessario regolare il tasso della molla elicoidale o la pressione dell'aria per ottenere il sag raccomandato per l'Instinct Powerplay™ SL. Consultare la tabella delle molle riportata di seguito per le raccomandazioni relative alle molle elicoidali e alle pressioni dell'aria.

### Rimbalzo

La regolazione del ritorno controlla la velocità alla quale la sospensione ritorna a estensione completa dopo un urto. Se il controllo del ritorno è eccessivo, la forcella o l'ammortizzatore si sposteranno troppo lentamente, affondando sempre di più nella loro escursione a seguito di urti ripetuti, dando una sensazione di rigidità. Se il controllo del ritorno è insufficiente, la sospensione e la molla possono ritornare indietro troppo velocemente, causando una perdita di trazione e di controllo.

LSR (Low Speed Rebound, ritorno a bassa velocità) si riferisce alla bassa velocità della forcella o dell'ammortizzatore, non alla velocità su sentiero. Questa regolazione influisce sulla velocità del ritorno nella prima parte dell'escursione. Per comodità, possiamo ipotizzare un'escursione compresa tra lo 0% e il 40%.

HSR (High Speed Rebound, ritorno ad alta velocità) si riferisce all'alta velocità della forcella o dell'ammortizzatore, non alla velocità su sentiero. Questa regolazione influisce sulla velocità del ritorno nella seconda parte dell'escursione. Per comodità, possiamo ipotizzare un'escursione compresa tra il 40% e il 100%.

## CONFIGURACIÓN DE LA SUSPENSIÓN

### Comprensione

La regolazione della compressione controlla la velocità con cui la sospensione si muove nella sua corsa quando colpisce un dosso. Se la regolazione della compressione è eccessiva, la forcella o l'ammortizzatore si muoveranno troppo lentamente e la forza dell'impatto dipenderà troppo dal pneumatico e dal corpo per assorbire il movimento. Se la compressione è troppo bassa, la forcella o l'ammortizzatore si muoveranno troppo velocemente e la bicicletta risulterà fiacca e poco reattiva.

La compressione a bassa velocità (LSC) si riferisce alla bassa velocità della forcella o dell'ammortizzatore, non alla velocità della pista. Controlla gli spostamenti del peso del ciclista, il pompaggio attraverso il terreno, le uscite in G e altri input lenti. Una quantità eccessiva di LSC determina una sensazione di guida più dura; una quantità troppo bassa di LSC determina una sensazione di guida troppo morbida e poco reattiva. L'LSC è efficace su tutta la gamma di escursione.

La compressione ad alta velocità (HSC) si riferisce all'alta velocità della forcella o dell'ammortizzatore, non alla velocità del sentiero. Controlla la capacità di assorbire gli impatti di grandi dimensioni, come le rocce squadrate e i colpi di fondo. Una quantità eccessiva di HSC determina una sensazione di guida più dura quando si percorrono sentieri veloci e accidentati con molte asperità di grandi dimensioni; una quantità insufficiente di HSC determina un sostegno insufficiente quando si colpiscono le asperità di grandi dimensioni e potrebbe portare all'utilizzo di tutta l'escursione della sospensione.

### Fondo idraulico

Il Bottom Out idraulico (HBO) si riferisce alla resistenza al bottom out che alcuni ammortizzatori possono fornire in combinazione con un regolatore esterno. Questa caratteristica riguarda l'ultimo 20% dell'escursione dell'ammortizzatore ed è utilizzata in caso di forti impatti in cui la bicicletta può andare a fondo corsa.

Le tabelle seguenti riportano tutte le configurazioni degli ammortizzatori OEM per l'Instinct Powerplay SL. A causa dell'elevato numero di ammortizzatori compatibili con l'Instinct Powerplay SL, non possiamo fornire guide di configurazione per modelli che non rientrano nelle specifiche OEM.

Suggerimenti e trucchi per le sospensioni

Quando mettete a punto le sospensioni, annotate le impostazioni in modo da poterle consultare in seguito. Meglio ancora, utilizzate un foglio di calcolo online sul vostro telefono!

La rimozione dell'ammortizzatore dell'Instinct Powerplay™ SL con il suo design di sospensione Smoothlink è facile, ma può richiedere alcuni suggerimenti e trucchi. Ecco una guida passo passo per la rimozione. Per l'installazione, è sufficiente seguire le istruzioni al contrario. Assicurarsi di osservare i valori di coppia inclusi nella sezione SOP di questo manuale.

1. Passare al pignone piccolo della cassetta e bloccare la gabbia del deragliatore aperta, se possibile.
2. Rimuovere la ruota.
3. Assicuratevi che le aree del telaio tra il tubo sella e la maglia siano pulite e prive di detriti.
4. Rimuovere il bullone dell'ammortizzatore anteriore.
  - a. Ricordate di sostenere il triangolo posteriore una volta rimossa la ferramenta dell'ammortizzatore anteriore e di estenderlo delicatamente all'indietro fino a quando il ponte del tubo sella non entra in contatto con il tubo di sicurezza.
5. Rimuovere il bullone dell'ammortizzatore posteriore.
  - a. Se necessario, è possibile rimuovere i chip Ride4 su entrambi i lati del collegamento.
6. Rimuovere l'urto
  - a. I distanziali dell'occhiello del cuscinetto su ciascun lato cadranno, quindi assicuratevi di mettere una mano sotto l'area dell'occhiello del cuscinetto per prenderli.

## CONFIGURAZIONE DELLE SOSPENSIONI

### 2025 INSTINCT POWERPLAY SL AMMORTIZZATORE FOX FLOAT X AIR SHOCK

DIMENSIONI AMMORTIZZATORE	SM - MD - LG - XL = 230 X 57.5MM	REGOLAZIONE AMMORTIZZATORE	0.4 SPACER, CS40, RL40, LMF, REZI B40			
NOTE	AUMENTARE LA PRESSIONE DI 10PSI   0.7BAR FOR SM *CONTEGGIO CLIC DA CHIUSO: 0 CLIC = CHIUSO*					
PESO DEL CICLISTA	PRESSIONE	SAG DELL'AMMORTIZZATORE	LSR	HBO	LSC	HSC
100lbs   45kg	120psi   8.3bar		10		9 - Open	
110lbs   50kg	130psi   9bar		10		9	
120lbs   55kg	140psi   9.7bar		10 - 9		8 - 9	
130lbs   59kg	150psi   10.3bar		9		8	
140lbs   64kg	160psi   11bar		9 - 8		7 - 8	
150lbs   68kg	170psi   11.7bar		8		7	
160lbs   73kg	180psi   12.4bar	SM - XL	8 - 7	Non disponibile	6 - 7	Non disponibile
170lbs   77kg	190psi   13.1bar	17 - 20mm	7		6	
180lbs   82kg	200psi   13.8bar		7 - 6		5 - 6	
190lbs   86kg	210psi   14.5bar		6		5	
200lbs   91kg	220psi   15.2bar		6 - 5		4 - 5	
210lbs   95kg	230psi   15.9bar		5		4	
220lbs   100kg	240psi   16.5bar		5 - 4		3 - 4	
230lbs   105kg	250psi   17.2bar		4		3	
240lbs   109kg	260psi   17.9bar		4 - 3		2 - 3	
250lbs   114kg	270psi   18.6bar		3		2	

### 2025 INSTINCT POWERPLAY SL AMMORTIZZATORE FOX FLOAT AIR SHOCK

DIMENSIONI AMMORTIZZATORE	XS = 210 X 52.5MM	REGOLAZIONE AMMORTIZZATORE	0.2 SPACER, CL, RM, CMF			
NOTE	AUMENTARE LA PRESSIONE DI 10PSI   0.7BAR FOR SM *CONTEGGIO CLIC DA CHIUSO: 0 CLIC = CHIUSO*					
PESO DEL CICLISTA	PRESSIONE	SAG DELL'AMMORTIZZATORE	LSR	HBO	LSC	HSC
100lbs   45kg	120psi   8.3bar		10			
110lbs   50kg	130psi   9bar		10			
120lbs   55kg	140psi   9.7bar		10 - 9			
130lbs   59kg	150psi   10.3bar		9			
140lbs   64kg	160psi   11bar		9 - 8			
150lbs   68kg	170psi   11.7bar		8			
160lbs   73kg	180psi   12.4bar	XS	8 - 7			
170lbs   77kg	190psi   13.1bar	15 - 18mm	7	Non disponibile	Avvio Aprire Regolare in base alle preferenze	Non disponibile
180lbs   82kg	200psi   13.8bar		7 - 6			
190lbs   86kg	210psi   14.5bar		6			
200lbs   91kg	220psi   15.2bar		6 - 5			
210lbs   95kg	230psi   15.9bar		5			
220lbs   100kg	240psi   16.5bar		5 - 4			
230lbs   105kg	250psi   17.2bar		4			
240lbs   109kg	260psi   17.9bar		4 - 3			
250lbs   114kg	270psi   18.6bar		3			

## CONFIGURAZIONE DELLE SOSPENSIONI

### 2025 INSTINCT POWERPLAY SL AMMORTIZZATORE PNEUMATICO ROCK SHOX SUPER DELUXE

REGOLAZIONE AMMORTIZZATORE	SM - MD - LG - XL = 230 X 57.5MM   BC EDITION = 230 X 60MM	REGOLAZIONE AMMORTIZZATORE	MD - LG - XL = 0 NEG 1 POS TOKEN - REBOUND 25 - COMP 30 - LOCKOUT 4 SM = 0 NEG 0 POS TOKENS - REBOUND 25 - COMP 26 - LOCKOUT 4			
NOTE	AUMENTARE LA PRESSIONE DI 10PSI   0.7BAR FOR SM *CONTEGGIO CLIC DA CHIUSO: 0 CLIC = CHIUSO*					
PESO DEL CICLISTA	PRESSIONE	SAG DELL'AMMORTIZZATORE	LSR	HBO	LSC	HSC
100lbs   45kg	120psi   8.3bar		11 - 12			
110lbs   50kg	130psi   9bar		10 - 11	Inizio a impostazione neutra (3a posizione)		
120lbs   55kg	140psi   9.7bar		9 - 11	Regola 1 clic alla volta per ottenere la sensazione di fondocorsa desiderata. Il fondocorsa idraulico	Inizio a impostazione neutra (3a posizione)	Inizio a impostazione neutra (3a posizione)
130lbs   59kg	150psi   10.3bar		8 - 9	opzionale interviene per limitare il flusso dell'olio nell'ultimo 20% dell'escursione, offrendo un morbido	Regola 1 clic alla volta per ottenere il supporto desiderato nei movimenti dell'albero a bassa velocità, come il pompaggio dei dossi,	Regola 1 clic alla volta per ottenere il supporto desiderato nei movimenti dell'albero ad alta velocità, come l'impatto contro spigoli vivi, i terreni rocciosi e i grandi salti.
140lbs   64kg	160psi   11bar	SM - XL 17 - 20mm	8 - 10	cuscino idraulico che riduce l'impatto del fondocorsa.	il precarico per un salto o una caduta, o un maggiore supporto nelle salite.	
150lbs   68kg	170psi   11.7bar		6 - 7			
160lbs   73kg	180psi   12.4bar	BC Edition 18 - 21mm	6 - 7			
170lbs   77kg	190psi   13.1bar		5 - 6			
180lbs   82kg	200psi   13.8bar		5 - 6			
190lbs   86kg	210psi   14.5bar		4 - 5			
200lbs   91kg	220psi   15.2bar		4 - 5			
210lbs   95kg	230psi   15.9bar		3 - 4			
220lbs   100kg	240psi   16.5bar		2 - 3			
230lbs   105kg	250psi   17.2bar		2 - 3			
240lbs   109kg	260psi   17.9bar		1 - 2			
250lbs   114kg	270psi   18.6bar		1 - 2			

### 2025 INSTINCT POWERPLAY SL AMMORTIZZATORE ROCKSHOX DELUXE AIR SHOCK

REGOLAZIONE AMMORTIZZATORE	XS = 210 X 52.5MM   BC EDITION = 210 X 55MM	REGOLAZIONE AMMORTIZZATORE	MD - LG - XL = 0 NEG 1 POS TOKENS, PROGRESSIVE REB-LOW COMP TUNE, 320LB LOCKOUT SM = 0 NEG 0 POS TOKENS, PROGRESSIVE REB-L1 COMP TUNE, 320LB LOCKOUT XS = 0 NEG 0 POS TOKENS, PROGRESSIVE REB-LOW COMP TUNE, 320LB THRESHOLD			
NOTE	AUMENTARE LA PRESSIONE DI 10PSI   0.7BAR FOR SM *CONTEGGIO CLIC DA CHIUSO: 0 CLIC = CHIUSO*					
PESO DEL CICLISTA	PRESSIONE	SAG DELL'AMMORTIZZATORE	LSR	HBO	LSC	HSC
100lbs   45kg	120psi   8.3bar		10			
110lbs   50kg	130psi   9bar		10			
120lbs   55kg	140psi   9.7bar		10 - 9			
130lbs   59kg	150psi   10.3bar		9			
140lbs   64kg	160psi   11bar		9 - 8			
150lbs   68kg	170psi   11.7bar	XS	8			
160lbs   73kg	180psi   12.4bar	15 - 18mm	8 - 7			
170lbs   77kg	190psi   13.1bar	BC Edition	7			
180lbs   82kg	200psi   13.8bar	16 - 19mm	7 - 6	Non disponibile	Avvio Aprire Regolare in base alle preferenze	Non disponibile
190lbs   86kg	210psi   14.5bar		6			
200lbs   91kg	220psi   15.2bar		6 - 5			
210lbs   95kg	230psi   15.9bar		5			
220lbs   100kg	240psi   16.5bar		5 - 4			
230lbs   105kg	250psi   17.2bar		4			
240lbs   109kg	260psi   17.9bar		4 - 3			
250lbs   114kg	270psi   18.6bar		3			

## DIMENSIONI CRITICHE

ITEM NUMBER	CATEGORY	ITEM	DIMENSION	PART NUMBER	DESCRIPTION	
1	Headset	Carbon Frame Headset	FSA No.85-10mm Offset		FSA No.85-10mm Offset Headset, complete. See Headset chart for information	
		Carbon Frame Headset Cup Set	FSA No.85-15mm Offset		FSA No.85-15mm Offset cups only. See Headset chart for information	
		Alloy Frame Headset	FSA ZS56 66 0mm Offset		FSA RMB ZS56 66 0mm Offset Headset, complete. See Headset chart for information	
		Alloy Frame Headset Cup Set	FSA ZS56 66 5mm Offset		FSA RMB ZS56 66 5mm Offset cups only. See Headset chart for information	
2	Fork	Fork Travel	150mm		Compatible with 160mm	
		Fork Offset	27.5"   XS = 37mm			
		Maximum Axle to Crown Height	29"   SM - MD - LG - XL = 42 - 44mm			
			27.5"   XS = 557.6mm			
3	Shock	Shock Size	XS = 210 x 52.5mm		XS frames are compatible with 210 x 55mm shocks. This increases rear wheel travel to 150mm.	
			SM - MD - LG - XL = 230 x 57.5mm		SM - MD - LG - XL frames are compatible with 230 x 60mm shocks. This increases rear wheel travel to 150mm.	
		Shock Tune	See Description		Refer to Shock Setup chart for tune information	
		Forward Shock Hardware	25 x 8mm		See Shock Hardware chart for information	
		Rear Shock Hardware	40 x 8mm	1811007	Requires custom bearing eyelet hardware. See Shock Hardware chart for information	
		Approved Shock Fitment	See Description		All Fox rear shock models. All RockShox rear shock models. All Cane Creek Shock models. Other rear shock manufacturers' models may fit, but will require fitment on frame to check clearances at full extension and compression.	
4	Seatpost	Seat Tube Inner Diameter	30.9mm		For seatpost fitment information, refer to the seatpost fitment section in this manual	
		Seat Tube Outer Diameter	34.9mm			
		Seat Tube Minimum Insertion	100mm			
		Seat Tube Machined Ream Depth (Identical on Carbon & Alloy)	XS = 220mm			
			SM = 230mm			
			MD = 275mm			
LG = 305mm						
	XL = 335mm					

## DIMENSIONI CRITICHE

ITEM NUMBER	CATEGORY	ITEM	DIMENSION	PART NUMBER	DESCRIPTION
		Chainring Size Range	34T		Instinct Powerplay SL bikes are only compatible with 34 tooth chainrings.
		OEM Chainring Size   Chain Length	27.5"   XS = 34T   122L 29"   SM - MD = 34T   122L 29"   LG - XL = 34T   124L		
5	Crankset	Lower Chain Guide Kit	See Description	1995026	Bashguard bracket with idler, 2025 Instinct Powerplay SL
		Chain Guide	See Description	1995013	Motor Output Chainguide, 2025 Instinct Powerplay SL
		Bashguard	2-Bolt Custom Mount		2-Bolt mounting pattern to fit Instinct Powerplay SL bashguards only
		Bottom Bracket	PressFit BB92		Remove the bottom bracket's inner plastic sleeve to install.
		Chainline	51mm		Compatible Rocky Mountain Ratchet Spider assembly only.
7	Brake	Maximum Rotor Diameter	223mm		
		Maximum Rotor Thickness	2.0mm		
8	Wheel	Wheel Size	XS = 27.5"		XS is only compatible with 27.5" wheels.
			SM - MD - LG - XL = 29"		MX compatible on all sizes with dedicated link (Link C   1815087)
		Maximum Tire Width	2.5"   63mm		
9	Rear Hub	Hub Spacing	12 x 148mm		
		Rear Axle	12 x 1.0 x 173mm	3222000	Diameter 12mm x Thread Pitch 1.0mm x Length 173mm
		Complete Hanger Kit	See Description	1812002	Includes Hanger, nut, and washer. For individual parts see exploded diagram
		UDH   Transmission	See Description		Frame is UDH and Eagle Transmission compatible.

## SPECIFICHE DI COPPIA DEI DISPOSITIVI DI FISSAGGIO

La corretta coppia di serraggio degli elementi di fissaggio filettati è molto importante per la vostra sicurezza. Serrare sempre gli elementi di fissaggio alla coppia corretta. In caso di conflitto tra le istruzioni del presente manuale e le informazioni fornite dal produttore del componente, consultare il rivenditore o il rappresentante del servizio clienti del produttore per ottenere chiarimenti. I bulloni troppo stretti possono allungarsi e deformarsi. I bulloni troppo allentati possono muoversi e affaticarsi. Entrambi gli errori possono portare a un cedimento improvviso del bullone.

Utilizzate sempre una chiave dinamometrica correttamente calibrata per serrare gli elementi di fissaggio critici della vostra bicicletta. Seguite attentamente le istruzioni del produttore della chiave dinamometrica sul modo corretto di impostarla e utilizzarla per ottenere risultati accurati.

### VISTA ESPLOSA

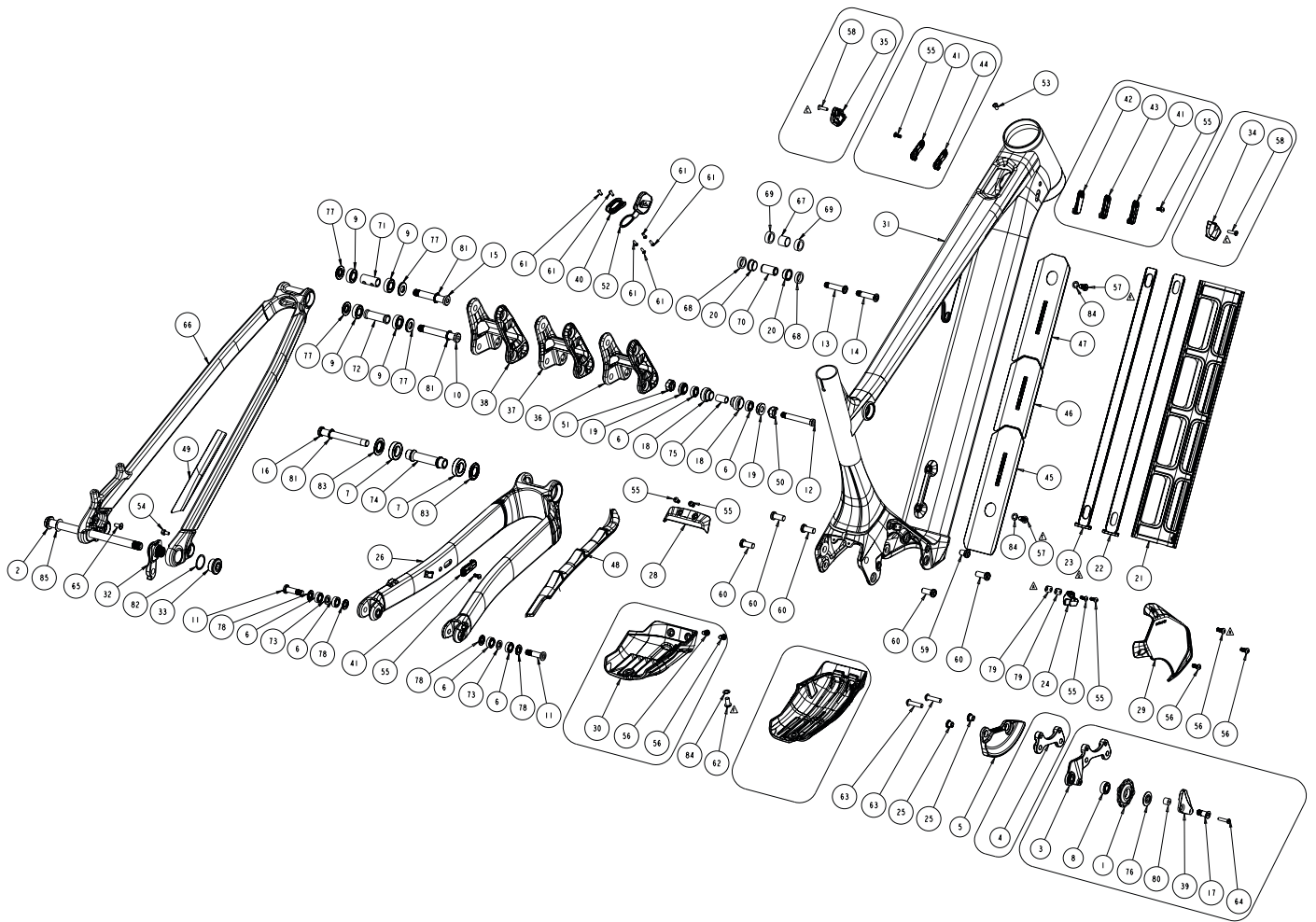

## ELENCO DEI KIT DI MINUTERIA

2025 INSTINCT POWERPLAY SL CARBON ALLOY							
# LIST	P1	QTY	ITEM	PART NO.	SUPPLIER	REVISION	DESCRIPTION
37	1	LINK		1815085 1095002	ZCA013		<b>2025 INSTINCT PP LINK 29"</b> MY25 INSTINCT POWERPLAY - LINK B
36	1	LINK		1815086 1095001	ZCA013		<b>2025 INSTINCT PP LINK 27.5"</b> MY25 INSTINCT POWERPLAY - LINK A
38	1	LINK		1815087 1095003	ZCA013		<b>2025 INSTINCT PP MULLET LINK</b> MY25 INSTINCT POWERPLAY - LINK C
32	1	HANGER		1812002 1092003	PTW047		<b>2022 HANGER KIT 12 x1.0</b> MY22 REAR DER. HANGER, M12X1, UDH COMPATIBLE
33	1	HANGER NUT		1801008	PTW047		RMB UDH HANGER NUT, 7075_T6, HARD BLACK ANODIZED
82	1	WASHER		1801009	PTW047		WASHER, 20X24X0.5MM, 304 SS
16	1	BOLT		1815088 1805154	PTW047		<b>2025 INSTINCT PP PIVOT BOLT KIT</b> BOLT, MAIN PIVOT, 10 MM OD, M10x1.25, 86 MM L, 6 MM HEX
10	1	BOLT		1801004	PTW047		LINK BOLT, LOWER, M10X1.0, L:70.5, 6MM HEX
15	1	BOLT		1804058	PTW047		UPPER LINK BOLT, M10x1.0, L:59.4
11	2	BOLT		1801007	PTW047		ALTITUDE DROPOUT BOLT, M8X1.0, L:30, 6MM HEX
71	1	SLEEVE		1800008	PTW047		TT BEARING SLEEVE, ID:10, OD:14, L:29
72	1	SLEEVE		1800010	PTW047		SS BEARING SLEEVE, ID:10, OD:14, L:41, NECKED
74	1	SLEEVE		1805156	PTW047		SLEEVE, MAIN PIVOT, 10MM ID, 52.5 MM L
73	2	SLEEVE		1800040	PTW047		DROPOUT BEARING SLEEVE, OD:14, ID:8, T:1.8, 6061 ALU
77	4	SPACER		1800009	PTW047		LINK BEARING SPACER, OD:22, ID:10, T:2.5
78	4	SPACER		1800039	PTW047		DO BEARING SPACER, OD:16, ID:8, T:1.75, 6061 ALU
81	3	WASHER		1800019	PTW047		WASHERID: 10.2, OD: 15.5, T:1
83	2	WASHER		1805155	PTW047		WASHER, MAIN PIVOT, 15MM ID, 27.5MM OD, 2.5MM T
11	2	BOLT		1814055 1801007	PTW047		<b>DROPOUT PIVOT BOLT KIT</b> ALTITUDE DROPOUT BOLT, M8X1.0, L:30, 6MM HEX
6	6	BEARING		1815089 1801010	ZCA013		<b>2025 INSTINCT PP PIVOT BEARING KIT</b> ENDURO 688 LLU MAX 16X8X5
9	4	BEARING		1807042			ENDURO 6900 2RS MAX 22X10X6
7	2	BEARING		1805159			ENDURO 6902 LLU MAX 28X15X7
12	1	BOLT		1815090 1802008	PTW047		<b>2025 INST PP AL SHOCK BOLT KIT</b> RIDE 4 BOLT, M8 x 1, OD: 8 mm, L:56, 5 mm Hex
14	1	BOLT		1804057			SHOCK BOLT, M8X1.0, L:35, 5mm HEX
12	1	BOLT		1815091 1802008	PTW047		<b>2025 INST PP CR SHOCK BOLT KIT</b> RIDE 4 BOLT, M8 x 1, OD: 8 mm, L:56, 5 mm Hex
13	1	BOLT		1803026			SHOCK BOLT, M8X1.0, L:36.5, 5mm hex
6	2	BEARING		1811007 1801010	ZCA013		<b>SHOCK BEARING EYELET KIT 2021</b> ENDURO 688 LLU MAX 16X8X5
75	1	SLEEVE		1807028	PTW047		BEARING EYELET CENTRE SLEEVE
18	2	BRG CUP		1800031	PTW048		BEARING EYELET FOR 16X8X5 BRG
19	2	BRG SPACER		1800032	PTW049		EYELET BEARING SPACER, T:6.3, FOR 40 MM LINK WIDTH
2	1	AXLE, REAR		1812007 3222000	PTW047		<b>AXLE KIT BOOST 12X1.0</b> REAR AXLE 12X1.0 L:173MM, HARD BLACK ANODIZE
85	1	WASHER		3227006	PTW047		WASHER, 12x19x0.5MM, 304 SS
34	1	HT PORT COVER		1815092 1803012	PTW047		<b>**** 2025 INST PP HT PANEL KIT (NEW)</b> 2023 SLAYER CARBON HT PORT COVER, RIGHT
35	1	HT PORT COVER		1803013	PTW047		2023 SLAYER CARBON HT PORT COVER, LEFT
58	2	SCREW		1805077-BK	PTW048		C'SUNK SOCKET SCREW, M4X16, STAINLESS STEEL, BLACK

## ELENCO DEI KIT DI MINUTERIA

		<b>1815093</b>	<b>ZCA013</b>	<b>POWERPLAY ALLOY FRAME HT CABLE PORT KIT</b>
55	3 SCREW	1804060		M4X0.7, 10MM, 2.5 HEX, BUTTON HEAD, SS, BLACK
41	3 PORT COVER	1093011		ALLOY CABLE PORT COVER DOUBLE HOLE
42	1 PORT COVER	1093012		ALLOY CABLE PORT COVER BLANK
43	1 PORT COVER	1093013		ALLOY CABLE PORT COVER SINGLE 4mm HOLE
44	1 PORT COVER	1093014		ALLOY CABLE PORT COVER SINGLE 5mm HOLE
		<b>1815094</b>		<b>ALLOY POWERPLAY FRAME CS CABLE PORT KIT STD SIZE</b>
41	1 PORT COVER	1093011		ALLOY CABLE PORT COVER DOUBLE HOLE
55	1 SCREW	1804060		M4X0.7, 10MM, 2.5 HEX, BUTTON HEAD, SS, BLACK
		<b>1812010</b>	<b>PTW047</b>	<b>RIDE 4 THREADED CHIP KIT</b>
50	1 RIDE 4 CHIP	1802009	PTW047	RIDE 4 CHIP, NO THREAD.
51	1 RIDE 4 CHIP	1802010	PTW047	RIDE 4 CHIP, THREADED, M8 x 1.
		<b>1815095</b>	<b>ZCA013</b>	<b>2025 INSTINCT PP PROTECTION KIT XS/SM</b>
48	1 PROTECTOR	1705006		2025 INSTINCT POWERPLAY CHAINSTAY PROTECTOR
49	1 PROTECTOR	3702021		SEATSTAY PROTECTOR, TRIMMED
45	1 PROTECTOR	1705003		DOWNTUBE PROTECTOR - A - 2025 INSTINCT POWERPLAY
46	2 PROTECTOR	1705004		DOWNTUBE PROTECTOR - B - 2025 INSTINCT POWERPLAY
		<b>1815096</b>	<b>ZCA013</b>	<b>2025 INSTINCT PP PROTECTION KIT MD/LG/XL</b>
48	1 PROTECTOR	1705006		2025 INSTINCT POWERPLAY CHAINSTAY PROTECTOR
49	1 PROTECTOR	3702021		SEATSTAY PROTECTOR, TRIMMED
45	1 PROTECTOR	1705003		DOWNTUBE PROTECTOR - A - 2025 INSTINCT POWERPLAY
46	1 PROTECTOR	1705004		DOWNTUBE PROTECTOR - B - 2025 INSTINCT POWERPLAY
47	1 PROTECTOR	1705005		DOWNTUBE PROTECTOR - C - 2025 INSTINCT POWERPLAY
		<b>1815097</b>		<b>2025 INSTINCT PP BB COVER SM/MD/LG/XL</b>
27	1 COVER	1995005		BOTTOM BRACKET COVER, CO-MOLDED, 2025 IPP
62	1 SCREW	1805170		SCREW, BUTTON HEAD, 18-8 SS, RAW STAINLESS, M6X1.0, 12MM LENGTH
84	1 WASHER	1805172		WASHER, 6x10x0.5MM, 304 SS
		<b>1815098</b>		<b>2025 INSTINCT PP BB COVER XS</b>
30	1 COVER	1995018		FOR X-SMALL ONLY, BOTTOM BRACKET COVER, 2025 INSTINCT POWERPLAY
62	1 SCREW	1805170		SCREW, BUTTON HEAD, 18-8 SS, RAW STAINLESS, M6X1.0, 12MM LENGTH
84	1 WASHER	1805172		WASHER, 6x10x0.5MM, 304 SS
56	2 SCREW	1804063		LOW PROFILE SOCKET HEAD SCREW, M5X10, STAINLESS STEEL, BLACK
		<b>1815099</b>		<b>2025 INSTINCT PP MAIN PIVOT COVER</b>
28	1 COVER	1995016		MAIN PIVOT COVER, 2025 INSTINCT POWERPLAY
55	2 SCREW	1804060		M4X0.7, 10MM, 2.5 HEX, BUTTON HEAD, SS, BLACK
		<b>1815100</b>	<b>PTW047</b>	<b>UDH STOP SCREW KIT M4X8</b>
54	1 SCREW	1802012		UDH STOP SCREW M4X8
		<b>1814050</b>	<b>ZCA013</b>	<b>5M OFFSET HEAD SET CUPS KIT CR BIKES</b>
1	HEAD SET CUP	1194002	PUS105	FSA 5MM OFFSET OVAL CUPS W/ORING CR BIKES
		<b>1814051</b>	<b>ZCA013</b>	<b>5M OFFSET HEAD SET CUPS KIT AL BIKES</b>
1	HEAD SET CUP	1194004	PUS105	FSA 5MM OFFSET CUPS AL BIKES
		<b>1814052</b>	<b>ZCA013</b>	<b>OVAL OFFSET HEADSET KIT CR BIKES</b>
1	HEADSET	1194001	PUS105	FSA NO.85 1.5" OMM OFFSET OVAL CUPS STAINLESS
		<b>1814053</b>	<b>ZCA013</b>	<b>OFFSET HEADSET KIT AL BIKES</b>
1	HEADSET	1194003	PUS105	FSA ZS56   66 OMM OFFSET HS STAINLESS STEEL
		<b>1815101</b>		<b>2025 INSTINCT PP BASH GUARD KIT</b>
5	1 BASH GUARD PLATE	1995028		BASH GUARD PLATE - 2025 INSTINCT POWERPLAY
25	2 CHAINRING BOLT	1805173		CHAINRING BOLT, CUSTOM, M8 X 0.75, LENGTH 6MM

**ELENCO DEI KIT DI MINUTERIA**

		<b>1815102</b>		<b>2025 INSTINCT PP CHAIN GUIDE KIT W/BASH GUARD</b>
5	1 BASH GUARD PLATE	1995028		BASH GUARD PLATE - 2025 INSTINCT POWERPLAY
4	1 BASH GUARD BRACKET	1995027		BASH GUARD BRACKET, WITHOUT IDLER - 2025 INSTINCT POWERPLAY
63	2 SCREW	1805171		SCREW, BUTTON HEAD, 18-8 SS, BLACK, M6X1.0, 25MM LENGTH
25	2 CHAINRING BOLT	1805173		CHAINRING BOLT, CUSTOM, M8 X 0.75, LENGTH 6MM
		<b>1815103</b>		<b>2025 INSTINCT PP CHAIN GUIDE KIT W/ BASH GUARD &amp; IDLER</b>
3	1 BASH GUARD BRACKET	1995026		BASH GUARD BRACKET, WITH IDLER - 2025 INSTINCT POWERPLAY
17	1 BOLT, M8X18	1807126		BOLT M8 X 18MM CUSTOM. 6061 HARD BLACK ANO.
39	1 PLATE	1094020		REAPER POWERPLAY LOWER PULLEY PLATE
64	1 SCREW, M4X20	1809011		C'SUNK SOCKET SCREW, M4x20mm, STAINLESS STEEL 316
80	1 SPACER	3399006		LOWER CHAIN GUIDE SPACER
1	1 11T COG	1347012	REV B	11T COG, FOR 19mm BEARING
8	1 BEARING	1807036		ENDURO 698 LLU 19X8X6
76	1 SPACER	1347013		CHAINSTAY PULLEY GUIDE SPACER,
5	1 BASH GUARD PLATE	1995028		BASH GUARD PLATE - 2025 INSTINCT POWERPLAY
63	2 SCREW	1805171		SCREW, BUTTON HEAD, 18-8 SS, BLACK, M6X1.0, 25MM LENGTH
25	2 CHAINRING BOLT	1805173		CHAINRING BOLT, CUSTOM, M8 X 0.75, LENGTH 6MM
		<b>1998024</b>		<b>CHAIN STAY PULLEY KIT</b>
1	1 11T COG	1347012	REV B	11T COG, FOR 19mm BEARING
8	1 BEARING	1807036		ENDURO 698 LLU 19X8X6
76	1 SPACER	1347013		CHAINSTAY PULLEY GUIDE SPACER,
		<b>1815104</b>	<b>PTW047</b>	<b>2025 INSTINCT POWERPLAY SL UPPER CHAIN GUIDE KIT</b>
24	1 CHAIN GUIDE	1995013		MOTOR OUTPUT CHAIN GUIDE, 2025 INSTINCT POWERPLAY
55	2 SCREW	1804060		M4X0.7, 10MM, 2.5 HEX, BUTTON HEAD, SS, BLACK
79	2 SPACER	1805191		CHAINGUIDE SPACER, 0.5MM, 304 STAINLESS STEEL, 2025 IPP
		<b>1815105</b>	<b>PTW047</b>	<b>2025 INSTINCT POPWERPLAY BATTERY BOLT KIT</b>
57	2 SCREW	1804065		M6 X 14MM, LOW BUTTON HEAD SCREW, SS, BLACK COATED
84	1 WASHER	1805172		WASHER, 6x10x0.5MM, 304 SS
		<b>1815106</b>	<b>PTW047</b>	<b>2025 INSTINCT POWERPLAY CHARGE PORT KIT</b>
40	1 PLATE	1995015		CHARGE PORT PLATE, 2025 INSTINCT POWERPLAY
52	1 RUBBER CAP	1995014		CHARGE PORT RUBBER CAP, 2025 INSTINCT POWERPLAY
61	6 SCREW	1805160		SCREW, BUTTON HEAD, 18-8 SS, BLACK, M3X0.5, L:8MM
		<b>1815107</b>	<b>PTW047</b>	<b>2025 INSTINCT PP SL ALLOY CABLE FLUTE XS/SM</b>
21	1 CABLE GUIDE	1995006		DOWNTUBE CABLE GUIDE FLUTE - 2025 INSTINCT POWERPLAY
22	1 CABLE GUIDE	1995007		DOWNTUBE CABLE GUIDE WEDGE - 2025 INSTINCT POWERPLAY
		<b>1815114</b>	<b>PTW047</b>	<b>2025 INSTINCT PP SL ALLOY CABLE FLUTE MD/LG/XL</b>
21	1 CABLE GUIDE	1995006		DOWNTUBE CABLE GUIDE FLUTE - 2025 INSTINCT POWERPLAY
23	1 CABLE GUIDE	1995048		DOWNTUBE CABLE GUIDE WEDGE - SLIM - 2025 IPP
		<b>1815108</b>	<b>PTW047</b>	<b>2025 INSTINCT POWERPLAY SL DRIVE SIDE MOTOR COVER</b>
29	1 COVER	1995017		DS COVER, 2025 INSTINCT POWERPLAY
56	3 SCREW	1804063		LOW PROFILE SOCKET HEAD SCREW, M5X10, STAINLESS STEEL, BLACK
		<b>1815109</b>	<b>PTW047</b>	<b>2025 INSTINCT POWERPLAY SL MOTOR MOUNT BOLT KIT</b>
60	5 SCREW	1805158		MOTOR MOUNTING SCREW, M8x1.25, 18 MM L, 304 SS, BUTTON HEAD
59	1 SCREW	1805157		MOTOR MOUNTING SCREW, M8x1.25, 10 MM L, 304 SS, BUTTON HEAD

## ELENCO DELLE PARTI E ISTRUZIONI DI MONTAGGIO

#	QTY ITEM	PART NO.	DESCRIPTION	SUPPLIER	TORQUE(Nm)	INSTALLATION NOTES
1	1	1347012	11T COG, FOR 19mm BEARING	OVERTOP		
2	1	3222000	REAR AXLE 12X1.0 L:173MM, HARD BLACK ANODIZE	OVERTOP		10 Grease axle shaft and threads
3	1	1995026	BASH GUARD BRACKET, WITH IDLER - 2025 INSTINCT POWERPLAY	SHING FONG		
4	1	1995027	BASH GUARD BRACKET, WITHOUT IDLER - 2025 INSTINCT POWERPLAY	SHING FONG		
5	1	1995028	BASH GUARD PLATE - 2025 INSTINCT POWERPLAY	CREATE THINK		
6	6	1801010	ENDURO 688 LLU MAX 16X8X5	ABI		Grease bearing race faces before installation
7	2	1805159	ENDURO 6902 LLU MAX 28X15X7	ABI		Grease bearing race faces before installation
8	1	1807036	ENDURO 698 LLU 19X8X6	ABI		Grease bearing race faces before installation
9	4	1807042	ENDURO 6900 2RS MAX 22X10X6	ABI		Grease bearing race faces before installation
10	1	1801004	LINK BOLT, LOWER, M10X1.0, L:70.5, 6MM HEX	OVERTOP		10 Grease axle shaft, Loctite 243 (blue) on threads
11	2	1801007	ALTITUDE DROPOUT BOLT, M8X1.0, L:30, 6MM HEX	OVERTOP		10 Grease axle shaft, Loctite 243 (blue) on threads
12	1	1802008	RIDE 4 BOLT, M8 x 1, OD: 8 mm, L:56, 5 mm Hex	OVERTOP		10 Grease axle shaft, Loctite 243 (blue) on threads
13	1	1803026	SHOCK BOLT, M8X1.0, L:36.5, 5mm hex	OVERTOP		10 Grease axle shaft, Loctite 243 (blue) on threads
14	1	1804057	SHOCK BOLT, M8X1.0, L:35, 5mm HEX	OVERTOP		10 Grease axle shaft, Loctite 243 (blue) on threads
15	1	1804058	UPPER LINK BOLT, M10x1.0, L:59.4	OVERTOP		10 Grease axle shaft, Loctite 243 (blue) on threads
16	1	1805154	BOLT, MAIN PIVOT, 10 MM OD, M10x1.25, 86 MM L, 6 MM HEX	OVERTOP		14 Grease axle shaft, Loctite 243 (blue) on threads
17	1	1807126	BOLT M8 X 18MM CUSTOM. 6061 HARD BLACK ANO.	OVERTOP		8 Grease axle shaft, Loctite 243 (blue) on threads
18	2	1800031	BEARING EYELET FOR 16X8X5 BRG	OVERTOP		
19	2	1800032	EYELET BEARING SPACER, T:6.3, FOR 40 MM LINK WIDTH	OVERTOP		
20	2	N/A	FOX_IGUS_BUSHING			
21	1	1995006	DOWNTUBE CABLE GUIDE FLUTE - 2025 INSTINCT POWERPLAY	CREATE THINK		
22	1	1995007	DOWNTUBE CABLE GUIDE WEDGE - 2025 INSTINCT POWERPLAY	CREATE THINK		
23	1	1995048	DOWNTUBE CABLE GUIDE WEDGE - SLIM - 2025 IPP	CREATE THINK		USE ONLY FOR ALLOY FT SIZE X-SMALL & SMALL
24	1	1995013	MOTOR OUTPUT CHAIN GUIDE, 2025 INSTINCT POWERPLAY	CREATE THINK		
25	2	1805173	CHAINRING BOLT, CUSTOM, M8 X 0.75, LENGTH 6MM	OVERTOP		
26	1	SEE TABLE	CHAINSTAYS - MY25 INSTINCT POWERPLAY	MK (RANBOW)		
27	1	1995005	BOTTOM BRACKET COVER, CO-MOLDED, 2025 IPP	CREATE THINK		
28	1	1995016	MAIN PIVOT COVER, 2025 INSTINCT POWERPLAY	CREATE THINK		
29	1	1995017	DS COVER, 2025 INSTINCT POWERPLAY	CREATE THINK		
30	1	1995018	FOR X-SMALL ONLY, BOTTOM BRACKET COVER, 2025 INSTINCT POWERPLAY	CREATE THINK		
31	1	SEE TABLE	FRONT TRIANGLE - MY25 INSTINCT POWERPLAY	MK (RANBOW)		
32	1	1092003	MY22 REAR DER. HANGER, M12X1, UDH COMPATIBLE	OVERTOP		
33	1	1801008	RMB UDH HANGER NUT, 7075_T6, HARD BLACK ANODIZED	OVERTOP		20 Apply loctite 243 (Blue) on hanger's external threads only
34	1	1803012	2023 SLAYER CARBON HT PORT COVER, RIGHT	OVERTOP		
35	1	1803013	2023 SLAYER CARBON HT PORT COVER, LEFT	OVERTOP		
36	1	1095001	MY25 INSTINCT POWERPLAY - LINK A	MK (RANBOW)		
37	1	1095002	MY25 INSTINCT POWERPLAY - LINK B	MK (RANBOW)		
38	1	1095003	MY25 INSTINCT POWERPLAY - LINK C	MK (RANBOW)		DO NOT ORDER, DO NOT INCLUDE
39	1	1094020	REAPER POWERPLAY LOWER PULLEY PLATE	OVERTOP		
40	1	1995015	CHARGE PORT PLATE, 2025 INSTINCT POWERPLAY	CREATE THINK		
41	3	1093011	ALLOY CABLE PORT COVER DOUBLE HOLE	CREATE THINK		
42	1	1093012	ALLOY CABLE PORT COVER BLANK	CREATE THINK		
43	1	1093013	ALLOY CABLE PORT COVER SINGLE 4mm HOLE	CREATE THINK		
44	1	1093014	ALLOY CABLE PORT COVER SINGLE 5mm HOLE	CREATE THINK		
45	1	1705003	DOWNTUBE PROTECTOR - A - 2025 INSTINCT POWERPLAY	CREATE THINK		
46	1	1705004	DOWNTUBE PROTECTOR - B - 2025 INSTINCT POWERPLAY	CREATE THINK		
47	1	1705005	DOWNTUBE PROTECTOR - C - 2025 INSTINCT POWERPLAY	CREATE THINK		
48	1	1705006	2025 INSTINCT POWERPLAY CHAINSTAY PROTECTOR	CREATE THINK		
49	1	3702021	SEATSTAY PROTECTOR, TRIMMED	VELO		
50	1	1802009	RIDE 4 CHIP, NO THREAD.	OVERTOP		
51	1	1802010	RIDE 4 CHIP, THREADED, M8 x 1.	OVERTOP		
52	1	1995014	CHARGE PORT RUBBER CAP, 2025 INSTINCT POWERPLAY	CREATE THINK		
53	1	1800024-BK	C'SUNK SOCKET SCREW, M4x10MM, 10.9 STEEL, BLACK	OVERTOP		1 Apply grease on screw threads
54	1	1802012	UDH STOP SCREW M4X8	OVERTOP		2 Apply loctite 243 (Blue) on screw threads
55	7	1804060	M4X0.7, 10MM, 2.5 HEX, BUTTON HEAD, SS, BLACK	OVERTOP		1 Apply grease on screw threads
56	5	1804063	LOW PROFILE SOCKET HEAD SCREW, M5X10, STAINLESS STEEL, BLACK	OVERTOP		2 Apply grease on screw threads
57	2	1804065	M6 X 14MM, LOW BUTTON HEAD SCREW, SS, BLACK COATED	OVERTOP		4 Dry installation
58	2	1805077-BK	C'SUNK SOCKET SCREW, M4X16, STAINLESS STEEL, BLACK	OVERTOP		1 Apply grease on screw threads
59	1	1805157	MOTOR MOUNTING SCREW, M8x1.25, 10 MM L, 304 SS, BUTTON HEAD	OVERTOP		10 Apply Loctite 243 (blue) on screw threads
60	5	1805158	MOTOR MOUNTING SCREW, M8x1.25, 18 MM L, 304 SS, BUTTON HEAD	OVERTOP		14 Apply Loctite 243 (Blue) on screw threads
61	6	1805160	SCREW, BUTTON HEAD, 18-8 SS, BLACK, M3X0.5, L:8MM	OVERTOP		0.5 Apply grease on screw threads
62	1	1805170	SCREW, BUTTON HEAD, 18-8 SS, RAW STAINLESS, M6X1.0, 12MM LENGTH	OVERTOP		4 Dry installation
63	2	1805171	SCREW, BUTTON HEAD, 18-8 SS, BLACK, M6X1.0, 25MM LENGTH	OVERTOP		8 Apply loctite 243 (Blue) on screw threads
64	1	1809011	C'SUNK SOCKET SCREW, M4x20mm, STAINLESS STEEL 316	OVERTOP		2 Apply loctite 243 (Blue) on screw threads
65	1	1807152	C'SUNK SOCKET SCREW, M5-0.8x12mm. STAINLESS BLACK	OVERTOP		2 Apply loctite 243 (Blue) on threads
66	1	SEE TABLE	SEATSTAYS - MY25 INSTINCT POWERPLAY	MK (RANBOW)		
67	1	N/A	SHOCK BUSHING, ID:12.7mm, OD:15mm, L:12.7mm, STEEL			
68	2	N/A	FOX STD REDUCER FOR 25MM PIN			
69	2	N/A	SRAM STD REDUCER FOR 25MM PIN			
70	1	N/A	SHOCK PIN: ID:8 x 25 mm LONG; ALUMINUM			
71	1	1800008	TT BEARING SLEEVE, ID:10, OD:14, L:29	OVERTOP		
72	1	1800010	SS BEARING SLEEVE, ID:10, OD:14, L:41, NECKED	OVERTOP		
73	2	1800040	DROPOUT BEARING SLEEVE, OD:14, ID:8, T:1.8, 6061 ALU	OVERTOP		

## ELENCO DELLE PARTI E ISTRUZIONI DI MONTAGGIO

74	1 SLEEVE	1805156 SLEEVE, MAIN PIVOT, 10MM ID, 52.5 MM L	OVERTOP	Grease bearing contact surfaces before installation
75	1 SLEEVE	1807028 BEARING EYELET CENTRE SLEEVE	OVERTOP	
76	1 SPACER	1347013 CHAINSTAY PULLEY GUIDE SPACER,	OVERTOP	
77	4 SPACER	1800009 LINK BEARING SPACER, OD:22, ID:10, T:2.5	OVERTOP	
78	4 SPACER	1800039 DO BEARING SPACER, OD:16, ID:8, T:1.75, 6061 ALU	OVERTOP	
79	2 SPACER	1805191 CHAINGUIDE SPACER, 0.5MM, 304 STAINLESS STEEL, 2025 IPP	OVERTOP	
80	1 SPACER	3399006 LOWER CHAIN GUIDE SPACER	SHING FONG	
81	3 WASHER	1800019 WASHERID: 10.2, OD: 15.5, T:1	OVERTOP	
82	1 WASHER	1801009 WASHER, 20X24X0.5MM, 304 SS	OVERTOP	
83	2 WASHER	1805155 WASHER, MAIN PIVOT, 15MM ID, 27.5MM OD, 2.5MM T	OVERTOP	
84	3 WASHER	1805172 WASHER, 6x10x0.5MM, 304 SS	OVERTOP	
85	1 WASHER	3227006 WASHER, 12x19x0.5MM, 304 SS	OVERTOP	

## IMMAGINI



## JUMBOTRON

Il display Jumbotron è il centro di comunicazione della bicicletta Powerplay™. Serve per far funzionare il sistema, visualizzare informazioni e diagnosticare e riparare i guasti. Gli aggiornamenti del firmware saranno eseguiti attraverso il modulo USB e il computer come necessario.



## IMMAGINI

### Telecomando TMI (Thumb-Machine Interface, interfaccia pollice-macchina)



## DISPLAY



## USO DELLA BICICLETTA

### Avvertenza

Assicurati di azionare i freni prima di esercitare qualsiasi pressione sui pedali o anche solo di appoggiarvi i piedi. La trasmissione Powerplay™ usa un circuito di rilevamento coppia sofisticato per erogare una potenza uniforme, istantanea e naturale. Tale circuito è molto sensibile e devi quindi prestare attenzione a evitare che la bicicletta acceleri allontanandosi da te mentre sei fermo.

### Accensione

Per avviare la trasmissione Powerplay™, usa il pulsante sul Jumbotron per accendere la bicicletta, tenendolo premuto per 2 secondi.

Nota: la trasmissione Powerplay™ si avvia sempre nella seconda modalità di assistenza più bassa. Il ciclista può quindi aumentare l'assistenza utilizzando l'unità di controllo remoto o il Jumbotron.

### Livelli di potenza

La trasmissione Powerplay™ offre diversi livelli di potenza dell'assistenza:

#### Livello 1: Eco

È l'impostazione di potenza più bassa, utilizzata per aumentare al massimo la durata della batteria e l'azione del ciclista.

#### Livello 2: Trail

Questo livello bilancia assistenza e durata della batteria per la guida generica su sentieri.

#### Livello 3: Trail+

Questo livello dà al ciclista una spinta sufficiente per una guida emozionante e una buona velocità nelle salite, senza scaricare eccessivamente la batteria.

#### Livello 4: Ludicrous

Questo livello eroga potenza elevata alla ruota posteriore, per dare la massima velocità e assistenza. Tieni presente che l'uso prolungato della modalità Ludicrous scarica la batteria piuttosto rapidamente. Per cambiare livello di assistenza, usa l'unità di controllo remoto (pulsante su o giù) o clicca il pulsante sul Jumbotron.

NOTA: IL CICLISTA PUÒ PERSONALIZZARE SIA LE IMPOSTAZIONI DI POTENZA DI TUTTE LE 4 MODALITÀ, SIA LA SPINTA DEL MOTORE (SENSIBILITÀ DI COPPIA) NEL  MENU PRINCIPALE. TIENI PREMUTO PER ACCEDERE.

## USO DELLA BICICLETTA

Il sistema di trasmissione Dyname S4 Lite è dotato di una modalità bambini regolabile che permette ai genitori di impostare un limite di velocità e di potenza per la bicicletta

Instinct Powerplay SL™ del proprio figlio.

Per attivare la modalità bambini, tieni premuto il pulsante  sul microtelecomando e accedi alle impostazioni.

### Blocco MENU per bambini

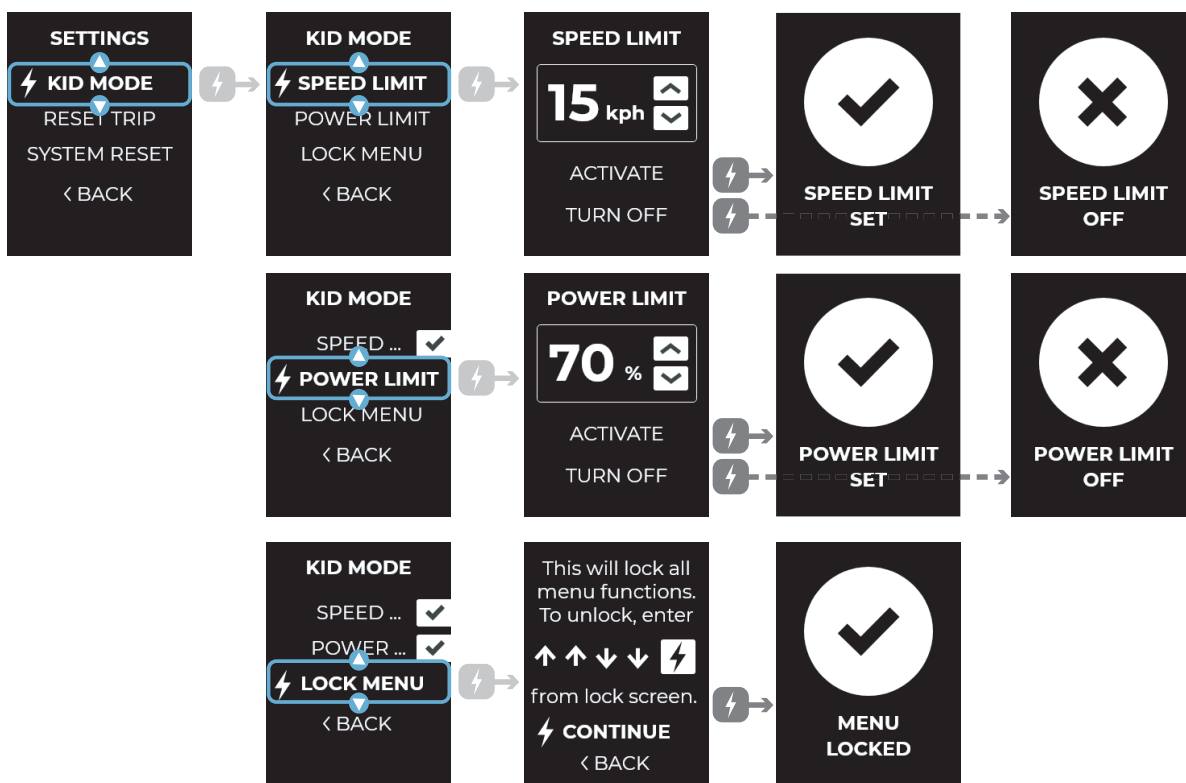

#### Con blocco attivo



La pressione del pulsante del menu fa apparire la schermata Menu bloccato. \*La schermata si chiude dopo 5 secondi se non si inserisce il codice.

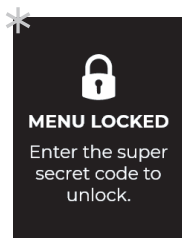

#### Sequenza di sblocco



Se si inserisce questa sequenza, viene visualizzato "Menu sbloccato" e vengono ripristinate le normali funzioni del menu

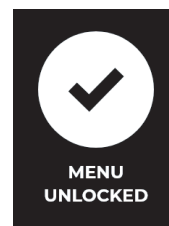

## REGOLAZIONE ASSISTENZA

I livelli di assistenza possono essere regolati all'inizio o in qualsiasi momento durante la corsa. Il sistema Dynamé™ 4.0 può tenere in memoria 3 diverse mappe di assistenza: una mappa FACTORY predefinita e due impostazioni personalizzabili. Il ciclista può scegliere tra le mappe a seconda della reazione desiderata del sistema di trasmissione.

### Selezione impostazione



### Regolazione impostazione

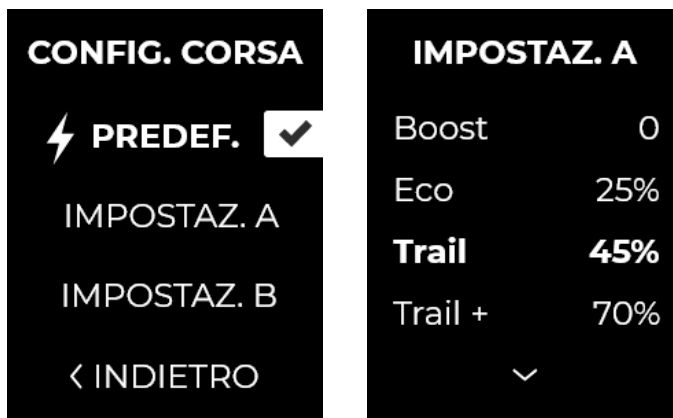

#### 2 parametri regolabili

- Boost: come il motore risponde all'input del ciclista (sensibilità di coppia o % di boost)
- Potenza assistenza: % della potenza disponibile per ciascuno dei 4 livelli di assistenza

## REGOLAZIONE ASSISTENZA

### Motor boost



#### Anpassung von +2 bis -2

**+2** Minimo sforzo richiesto al ciclista. Spinta massima, autonomia della batteria minima: BRAAAAAAP

**0** Prestazioni equilibrate, buona risposta e autonomia della batteria

**-2** Sforzo di pedalata significativo richiesto al ciclista, autonomia della batteria massima, ottimale per allenamento.

### Potenza assistenza

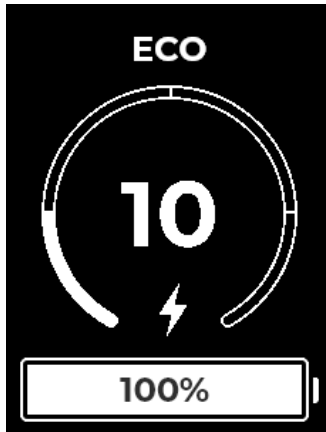

#### Regolazione da 1% a 100%

Per ciascuna delle 4 modalità di assistenza (Eco, Trail, Trail+, Ludicrous) puoi selezionare la potenza erogata. La percentuale si riferisce al picco di potenza disponibile. Non puoi regolare la potenza di una modalità di assistenza alta su un livello inferiore a quello di una modalità di assistenza bassa; ad es., la modalità Trail non può essere regolata su una potenza più bassa della modalità Eco.

## BATTERIA

La Instinct Powerplay SL™ ha comandi, motori e componenti della batteria proprietari. Alcuni di questi componenti sono sensibili e richiedono precauzioni aggiuntive. Vogliamo assicurarci che tu abbia più informazioni possibili. Prendi nota dei seguenti dettagli aggiornati relativi alla batteria della Powerplay™ di Rocky Mountain e alla sua ricarica e manutenzione. Il mancato rispetto delle istruzioni e delle linee guida contenute in questa sezione può provocare danni ai componenti elettrici della bicicletta e invalidare la garanzia. Ancora più importante, il mancato rispetto delle istruzioni può provocare lesioni personali gravi o letali.

### Informazioni generali

- Le batterie utilizzate in tutti i dispositivi Powerplay™ di Rocky Mountain hanno tutte le certificazioni richieste e un sistema di gestione della batteria (Battery Management System, BMS) che prevede più livelli di protezione dai guasti, per prevenire i pericoli. Nonostante queste misure di sicurezza, una batteria carica che ha raggiunto temperature estreme o una porta di ricarica che ha subito danni può comportare pericoli, causando scosse elettriche, incendi o lesioni.
- Se la batteria o il caricabatterie mostrano segni di danni, non li utilizzare e porta immediatamente la bicicletta al tuo rivenditore autorizzato Rocky Mountain per un controllo.
- La batteria e l'unità di trasmissione, così come gli altri componenti proprietari della Powerplay™, devono essere riparati solo da meccanici che hanno seguito la formazione di Rocky Mountain sulla Powerplay™.
- Evita il contatto di oggetti piccoli, appuntiti e/o metallici con la batteria o la presa di caricamento della batteria.
- Non modificare, aprire o smontare la batteria o il caricabatterie.
- Non pulire mai una bicicletta Powerplay™ con una lancia ad alta pressione né immergerla in acqua. La pioggia e il normale lavaggio non causano problemi.
- Una batteria integra non rilascia fluidi o gas. Tuttavia, in caso di danni, la batteria può rilasciare un liquido che può causare irritazioni e ustioni alla pelle e un gas irritante per le vie respiratorie. In caso di contatto della pelle o degli occhi con qualsiasi fluido o gas della batteria, lava immediatamente con acqua e rivolgiti a un medico.
- Quando trasporti la bicicletta su un'auto, se la batteria viene rimossa, assicurati che tutti i collegamenti siano coperti per evitare contaminazioni da detriti stradali, acqua e sale.
- Se si verifica un incendio della batteria, non tentare di estinguerlo direttamente con acqua. Puoi usare acqua sui materiali incendiati attorno alla batteria, ma non sulle celle chimiche stesse. Per estinguere correttamente le fiamme da una batteria, utilizza un estintore di classe ABC o BC. Puoi anche utilizzare sabbia per estinguere il fuoco. Se possibile, senza esporti al rischio di lesioni personali, se una batteria si surriscalda o si incendia, porta la batteria o l'intera bicicletta all'aperto per evitare che il fuoco si propaghi. Se la batteria è collegata a un caricabatterie, la prima cosa da fare è scollegare il caricabatterie o staccare la corrente.

### Ricarica

- Usa solo i caricabatterie specifici della Powerplay™ per qualsiasi batteria della Powerplay™.
- Non lasciare il caricabatterie esposto alla luce solare diretta, in particolare durante la ricarica.

### Per ricaricare la batteria:

1. Individua la porta di ricarica sulla bicicletta Powerplay™ e apri la protezione della porta di ricarica.
2. Osserva la forma del connettore del cavo di ricarica e orientalo correttamente verso la porta di ricarica della bicicletta. Collega il caricabatterie alla bicicletta Powerplay™.
3. Inserisci il caricabatterie in una presa elettrica. Il LED sul caricabatterie si illuminerà con luce rossa per indicare che è in corso la ricarica.



## BATTERIA

- Quando la batteria è prossima alla carica completa, il sistema rallenta la velocità di carica per raggiungere la piena capacità delle celle ed equilibrarle. Il LED del caricabatterie può visualizzare alternativamente «in carica (rosso)» e «carica completa (verde)», a intervalli di 30 secondi, per 30 minuti. Se il LED rimane verde per più di 5 minuti, la batteria è completamente carica. Non è necessario scollegare il caricabatterie immediatamente dopo il completamento della ricarica; evita tuttavia di lasciare la bicicletta collegata al caricabatterie per un periodo superiore alle 12 ore.

### NOTE:

- Non confondere questo comportamento di fine carica con un guasto del sistema, che causa invece un lampeggiamento rapido del caricabatterie.
- Questo stato di fine carica rappresenta l'ultimo 3% della carica della batteria. Puoi scollegare il caricabatterie in qualsiasi momento se sei soddisfatto del livello della batteria.
  - Ricarica la tua bicicletta Powerplay™ in un'area aperta con accesso libero a un'uscita esterna.
  - Come per qualsiasi bicicletta e apparecchiatura con batterie agli ioni di litio, si raccomanda di ricaricare la bicicletta solo sotto supervisione.
  - Se la temperatura della batteria raggiunge i 50 °C, la ricarica si arresta fino a quando la temperatura scende a 45 °C. Se la temperatura della batteria scende a 0 °C, la ricarica si arresta fino a quando la temperatura sale a 3 °C.
- Il tempo di ricarica è il seguente:

480 Wh	Caricabatterie da 4 A	Caricabatterie da 2 A
Tempo di ricarica da 0 a 80%	1h55	4h00
Tempo di ricarica da 0 a 95%	2h20	4h40
Tempo di ricarica totale da 0 a	2h35	5h05

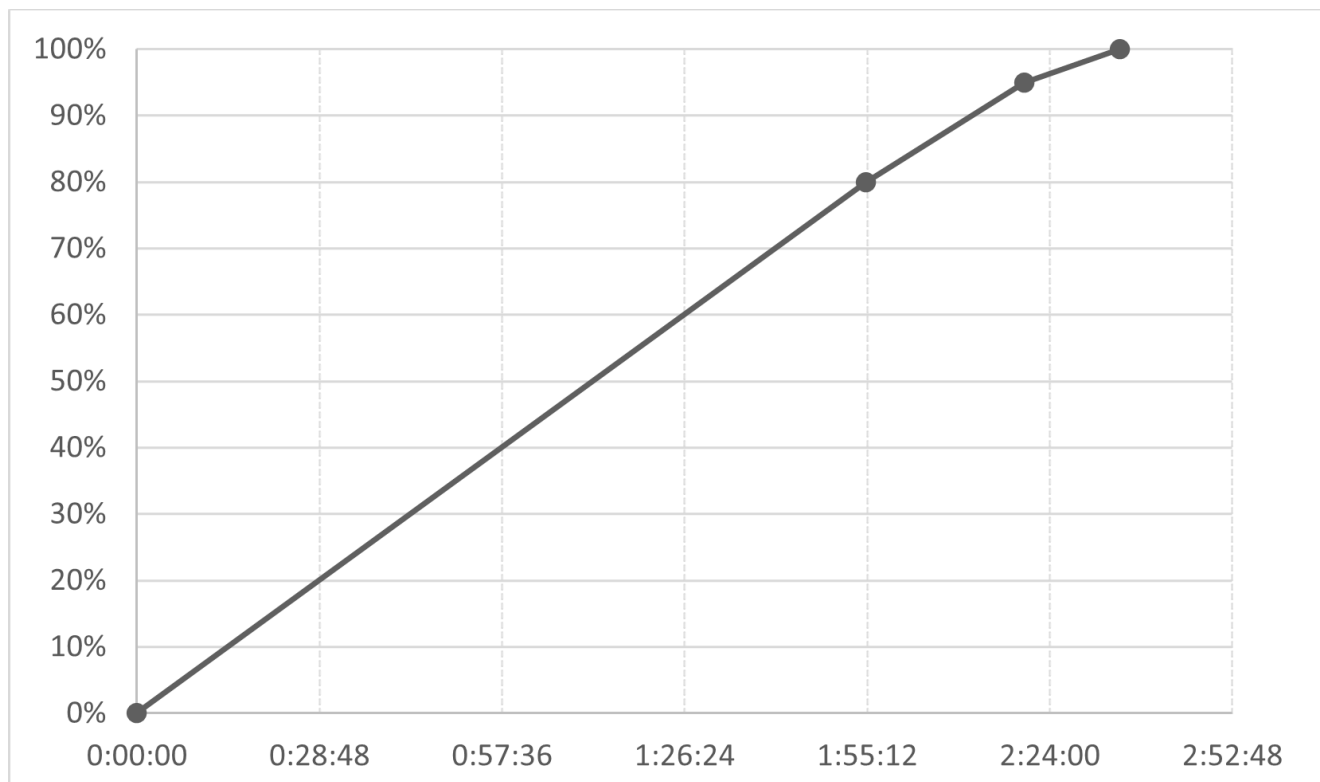

## BATTERIA

### Stoccaggio

- Per stoccare la tua bicicletta Powerplay™, tienila in un luogo sicuro non esposto a temperature estreme (sopra i 30 °C o sotto i -20 °C) o con eccessivo irradiazione solare, umidità o condensa. Se pensi che la bicicletta sia stata conservata nelle condizioni sopra elencate, non utilizzarla e contatta il tuo rivenditore autorizzato Rocky Mountain.
- Conservare una batteria completamente scarica per un periodo prolungato causerà danni e ne ridurrà la capacità. Si consiglia di scollegare la batteria prima della conservazione a lungo termine che supera le 2 settimane. Si consiglia inoltre di ricaricare la batteria almeno fino al 75% della capacità, quando possibile, per evitare danni dovuti a scariche profonde per periodi di conservazione prolungati che superano le 2 settimane.
- If you store your bike for long periods of time, you must recharge the battery periodically, at least once every three months, to maintain its capacity. Failure to do so may cause damage to the battery, and a loss of its capacity. A good way to manage storage recharging is to set calendar reminders in your computer or mobile device.
- Il modo migliore per mantenere la capacità ottimale della batteria nel tempo è quello di stoccare la bicicletta a temperature comprese tra 10 °C e 25 °C e un'umidità relativa inferiore al 65%.
- Dopo 1 mese di conservazione, la batteria entrerà in una modalità di protezione. Per ripristinare la batteria, collegare il caricabatterie.

### Funzionalità della batteria

- La batteria funziona in ambiente freddo, anche se con una capacità ridotta. A una temperatura di -10 °C riscontrerai circa il 70% della capacità piena. Se la bicicletta è fredda, raccomandiamo di riscaldarla prima dell'uso.
- Se la temperatura della batteria raggiunge i 65 °C, si spegnerà per protezione finché non scenderà sotto i 60 °C. Se la temperatura della batteria raggiunge i -20 °C, si spegnerà per protezione finché non tornerà ad almeno -15 °C.
- Quando la capacità residua della batteria è bassa, la trasmissione Powerplay™ ridurrà progressivamente la potenza in uscita per massimizzare l'autonomia.
- Tieni presente che le batterie agli ioni di litio perdono gradualmente capacità in base all'età e all'uso. Una diminuzione netta della capacità può essere un segno che la batteria sta raggiungendo la fine della sua vita e deve essere sostituita. Rivolgiti al tuo rivenditore autorizzato Rocky Mountain per la sostituzione della batteria. In condizioni di uso normale puoi prevedere questa durata:

#### **480 Wh**

Funzionerà all'80% della capacità piena dopo 500 cicli di carica completa (ricarica da 0% a 100%).

## BATTERIA

### LED batteria

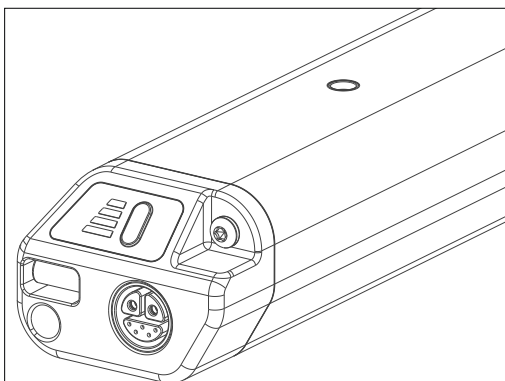

### Indicazione livello batteria

- **Premi brevemente il pulsante della capacità**  
Premi il pulsante della capacità per meno di 1 secondo all'accensione.

#### INDICAZIONE LED CAPACITÀ BATTERIA (LED 4,3,2,1)

#### Capacità residua batteria

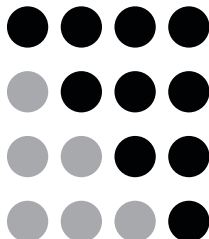

100%-75%

74,9%-50%

49,9%-25%

24,9%-0%

### Durante la caric

- **Indicazione di carica in corso**

#### INDICAZIONE LED CAPACITÀ BATTERIA (LED 4,3,2,1)

#### Capacità residua batteria

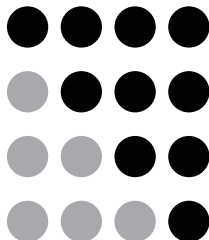

100%-75%

74,9%-50%

49,9%-25%

24,9%-0%

● : luce spenta

● : luce fissa

☀ : lampeggiante

## SCHERMATE DI GUIDA

A seconda della selezione, la schermata visualizzerà un tipo di informazioni, continuando comunque a mostrare i dati critici. Questa schermata mostra informazioni relative alla corsa, come la velocità, la cadenza, il livello di assistenza e il livello di boost, tutto in un'unica schermata.

### Schermate della corsa

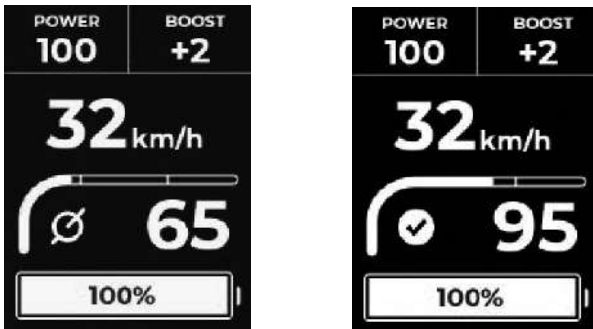

### Vista velocità

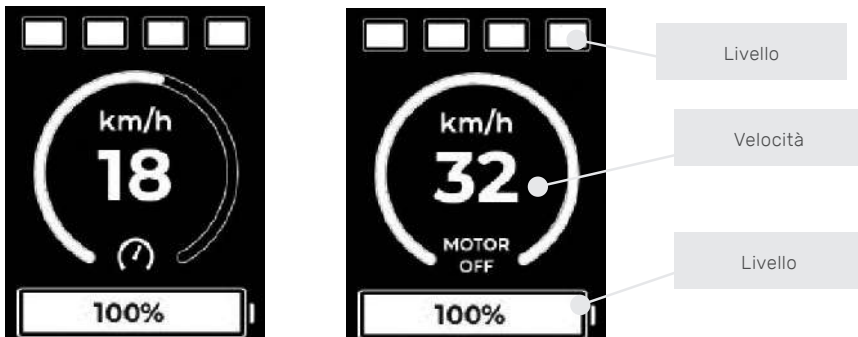

### Vista batteria

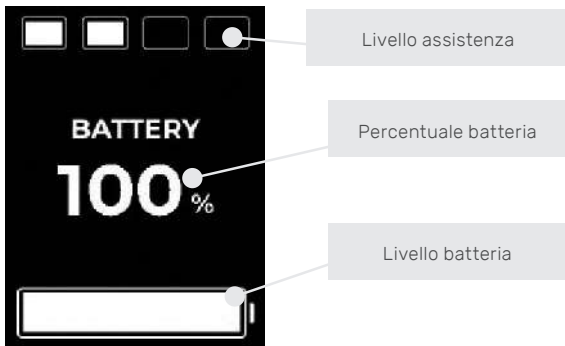

## SCHERMATE DI GUIDA

### Vista assistenza

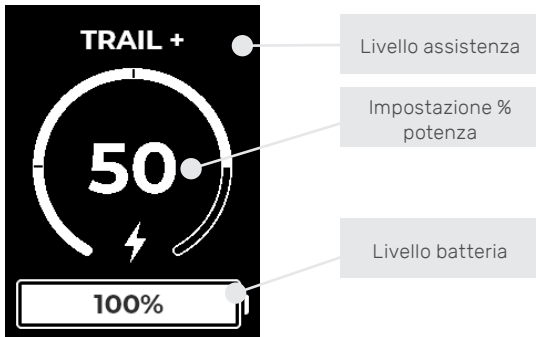

### Vista cadenza

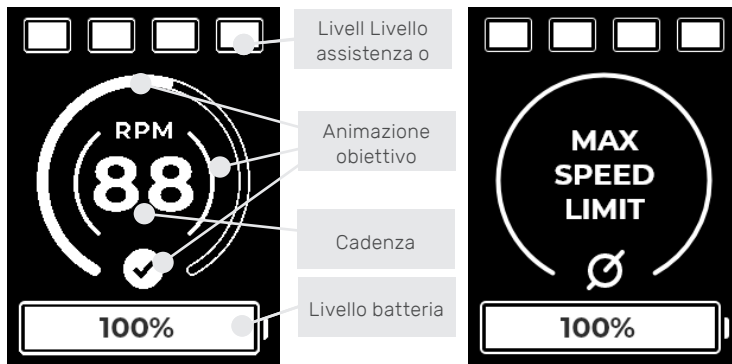

Nota: la cadenza è stimata in base ai giri/min del motore. Questo significa anche che quando il motore è fermo (ad es: sopra la velocità massima), la cadenza non viene rilevata.

### Vista contachilometri/giri

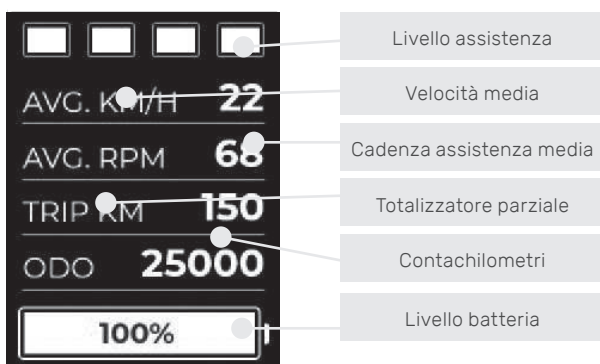

## REIMPOSTAZIONE

Il ciclista può sempre reimpostare le informazioni sul giro (velocità media, cadenza media, distanza), nonché ripristinare le impostazioni originali di fabbrica del sistema Dyname.

### Reimpostazione giro

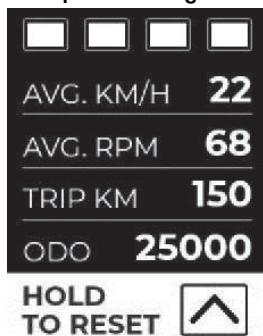

Nella vista del contachilometri, tieni premuto il pulsante SU del TMI

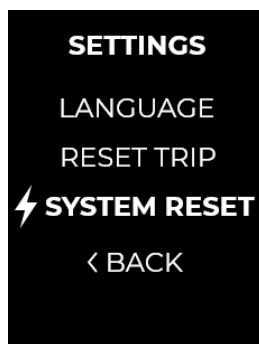
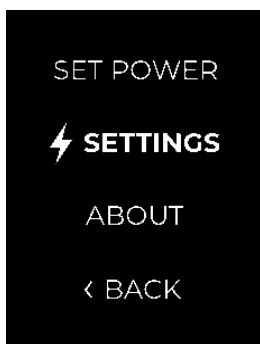

Da qualsiasi schermata di guida, vai al menu principale

TENENDO PREMUTO ⚡. Vai a Impostazioni - Reimpost. sistema.

### Modalità cammino

La Powerplay™ ha una modalità cammino che puoi utilizzare in caso di necessità. La trasmissione Powerplay™ è in grado di assistere la bicicletta a una velocità da cammino. Sul telecomando tieni premuto il pulsante GIÙ. La bicicletta procederà lentamente in salita mentre tieni premuto il pulsante.

La modalità cammino non può essere utilizzata mentre il ciclista è sulla bicicletta. Puoi usare la modalità cammino solo quando cammini a fianco della bicicletta.

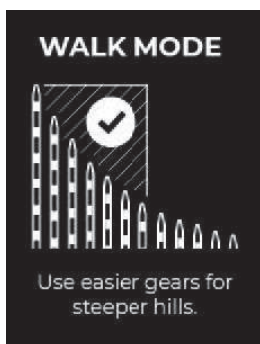

### Spegnimento

Per spegnere la trasmissione Powerplay™, tieni premuto il pulsante sul Jumbotron. Se la bicicletta viene lasciata inutilizzata per 10 minuti, si spegne automaticamente per preservare la durata della batteria.

### Prompt

Appare dopo aver tenuto premuto il pulsante di accensione per 0,5 secondi.



### Spegnimento

Appare dopo aver tenuto premuto il pulsante di accensione per 2,5 secondi.

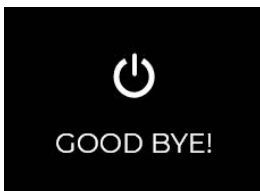

## NOTE

### Danneggiamento del telecomando

Nel caso in cui il telecomando subisca danni e smetta di funzionare, il ciclista può continuare a usare la bicicletta e a cambiare modalità di assistenza utilizzando il Jumbotron.

NOTA: i menu e le regolazioni non sono accessibili tramite il Jumbotron, senza il telecomando.

### Autonomia

La distanza per la quale la batteria è in grado di alimentare il sistema di trasmissione varia a seconda di diversi fattori, come il livello di assistenza e la modalità di boost selezionati, la temperatura ambiente, l'accelerazione, la resistenza del vento, le condizioni di manutenzione, l'età della batteria, i dislivelli e le asperità del terreno e/o il peso del ciclista.

### Suggerimenti di guida

- La trasmissione Dymate S4 Lite eroga una potenza uniforme e naturale alla ruota posteriore e funziona al meglio nelle condizioni seguenti.
- Pedala in modo uniforme e costante, invece di dare colpi ai pedali.
- Cambia spesso rapporto, per mantenere una cadenza tra 80 e 120 giri al minuto, che consente un'efficienza ottimale del motore e il raggiungimento di una coppia elevata e delle massime prestazioni della batteria. Usa la vista cadenza sul Jumbotron, che informa il ciclista quando sta pedalando nella zona di massima efficienza.
- Quando cambi i rapporti, presta attenzione a:
  - Ridurre la pressione sui pedali prima di cambiare per evitare di sollecitare eccessivamente la catena.
  - Non cambiare più di un rapporto alla volta.

## INTERVENTI

### Diagnostica e riparazioni

Il Jumbotron può visualizzare messaggi di errore e, in alcuni casi, fornire al ciclista istruzioni per riparare il sistema.

#### Esempio



### Calibrazione

Occasionalmente può essere necessaria una procedura di calibrazione per mantenere le prestazioni del sistema di trasmissione. Di solito questo viene fatto ogni volta che viene sostituito un componente della trasmissione (catena, ingranaggio, pignone, ecc.) o il motore viene reinstallato nel telaio.



## SERVIZIO

### Risoluzione dei problemi

Per la risoluzione dei problemi rivolgiti al tuo rivenditore locale. Il display Jumbotron può generare codici di errore per la diagnostica. Quando appare un codice d'errore, il sistema visualizzerà istruzioni. In alcuni casi può essere possibile effettuare una riparazione sul posto, in altri casi il ciclista potrebbe doversi rivolgere al rivenditore autorizzato. Alcuni errori attivano una modalità a potenza ridotta che permette al ciclista di tornare a casa.

### Avviso

AVVISO - Non manomettere la tua bicicletta Rocky Mountain. La manomissione consiste nel rimuovere o sostituire qualsiasi equipaggiamento originale o modificare la bicicletta Rocky Mountain in qualsiasi modo che possa cambiarne il design e/o funzionamento. Tali modifiche possono gravemente compromettere la maneggevolezza, la stabilità e altri aspetti della bicicletta, rendendola insicura da guidare. La manomissione può invalidare la garanzia e rendere la tua bicicletta Rocky Mountain non conforme alle leggi e ai regolamenti applicabili nel luogo in cui la bicicletta viene utilizzata. Per garantire sicurezza, qualità e affidabilità, utilizza solo parti originali o ricambi autorizzati Rocky Mountain Bicycles per le riparazioni e le sostituzioni. Rocky Mountain Bicycles non è responsabile di alcun danno diretto, incidentale o conseguente, compresi, senza limitazione, i danni per lesioni personali, danni alla proprietà o perdite economiche dovute alla manomissione.

#### *Attenzione:*

Il livello di pressione sonora delle emissioni con ponderazione A alle orecchie del conducente è inferiore a 70 dB[A].

## MANUTENZIONE GENERALE

Tieni presente che le biciclette elettriche a pedalata assistita causano più stress e sollecitazioni sui componenti rispetto alle mountain bike tradizionali. I controlli e la manutenzione devono quindi essere eseguiti più spesso per massimizzare sicurezza, prestazioni e durata.

### Carica stagionale

Se tieni la bicicletta inutilizzata per lunghi periodi di tempo, assicurati di caricare la batteria almeno una volta ogni tre mesi. In caso contrario, la batteria può danneggiarsi e perdere capacità. Dopo un mese di mancato utilizzo, la batteria entra in modalità di protezione. Per riattivare la batteria, collegala al caricabatterie.

Un buon modo per ricordarsi di ricaricare una batteria non utilizzata è impostare dei promemoria nel computer o nello smartphone.

### Pulizia

Una bicicletta pulita è una bicicletta felice. Il modo migliore per pulire una bicicletta sporca è con un secchio di acqua calda saponata. Evita di usare una lancia ad alta pressione.

NOTA: non spruzzare acqua direttamente su nessun componente elettrico.

### Manutenzione preventiv

Pulizia della trasmissione e controllo dello stato di usura.

- Catena
- Rapporti
- Pulegge (ruota folle inferiore, pulegge del deragliatore)
- Corona
- Pignone trasmissione

Controlla i bulloni e i dispositivi di fissaggio

- Tutti i dispositivi di fissaggio standard della bicicletta: perni, stelo, viti delle pedivelle, bulloni della corona
- Supporti del motore
- Supporto del sensore di coppia
- Prigioniero della batteria
- Controllo della tensione dei raggi
- Ispezione delle pastiglie dei freni e dei rotori
- Mantenere la porta di ricarica pulita/chiusa

## MANUTENZIONE

Lista di controllo per la regolazione e la manutenzione periodica	Lista di controllo					Notes
	500KM	1000KM	1500KM	2000KM	2500KM	
Catena della bicicletta - controllare l'usura, pulire e lubrificare	Prima di ogni utilizzo					Controllarne lo stato (allungamento, crepe) e lubrificarla con il lubrificante raccomandato dal fornitore della catena.
Porta di ricarica	Prima di ogni ricarica					Controllare se vi sono infiltrazioni d'acqua, corrosione o sporcizia e verificare l'allineamento dei piedini
Sensore di coppia - calibrazione	Due volte al mese					OPPURE ogni volta che si sostituisce un componente del sistema di trasmissione
Viti di montaggio motore	●	●	●	●	●	Controllare che la coppia di serraggio sia adeguata
Pignone trasmissione e ghiera	●	●	●	●	●	Controllare lo stato; sostituire quando l'usura raggiunge il limite
Sensore coppia e ruota folle inferiore	●	●	●	●	●	Controllare se ci sono incrinature o danni
Carter e coperchi del motore		●		●		Controllare se ci sono incrinature o danni
Cavi del motore		●		●		Controllare se ci sono danni alla guaina isolante o ai connettori
Alloggiamento batteria	Ispezionare ogni volta che la batteria non è inserita nella bicicletta					Controllare se ci sono danni all'alloggiamento o ai connettori
Unità di controllo remoto sul manubrio e cavo	●	●	●	●	●	Controllare se ci sono danni all'alloggiamento o ai connettori
Display sul tubo orizzontale e cavo	●	●	●	●	●	Controllare se è allentato e se lo schermo è danneggiato
Cavo di prolunga del tubo obliquo	●	●	●	●	●	Controllare se ci sono danni all'alloggiamento o ai connettori
Sensore di velocità e cavo	Ispezionare ogni volta che la ruota è smontata dalla bicicletta					Controllare se ci sono danni all'alloggiamento o ai connettori; verificare che i magneti siano ben fissati
Catena - pulire e lubrificare		●		●		Controllarne lo stato e lubrificarla con lo stesso olio usato per la catena della trasmissione.
Catena - sostituire	Sostituire ogni 2500 KM					Controllare lo stato per evitare rumori e usura interna del motore
Cuscinetto frizione del motore - sostituire	Sostituire ogni 2500 KM					Controllare il funzionamento del cuscinetto
Cuscinetto frizione del motore - sostituire	Sostituire ogni 2500 KM					Controllare il funzionamento del cuscinetto

## GARANZIA

### RICAMBI E ACCESSORI

Si prega di acquistare parti di ricambio e accessori Rocky Mountain tramite il rivenditore autorizzato Rocky Mountain locale. Ti consigliamo vivamente di avere una camera d'aria di scorta e gli strumenti necessari per la sostituzione della camera d'aria quando esci in bicicletta.

### TRASPORTO

Il trasporto e/o la spedizione della tua bicicletta dotata di trasmissione Powerplay™ possono essere soggetti a restrizioni e richiedere procedure speciali di movimentazione, etichettatura e/o imballaggio. Informati in anticipo su tutti i requisiti legali del tuo paese. Quando trasporti la bicicletta su un'auto, se la batteria viene rimossa, assicurati che tutti i collegamenti siano coperti per evitare contaminazioni da detriti stradali, acqua e sale.

### REGISTRAZIONE

La procedura di registrazione della tua bicicletta è il modo ufficiale di accoglierti nella famiglia Rocky Mountain. È inoltre una tappa importante per attivare la garanzia della tua bicicletta. Nel caso in cui si verificasse un problema, potremo gestire il tuo caso in maniera efficiente e farti risalire in sella il più presto possibile. La procedura di registrazione è semplice e richiede solo alcuni minuti.

Register your bike: [bikes.com/register](https://bikes.com/register)



## GARANZIA

La bicicletta Powerplay™ di Rocky Mountain è coperta da garanzia contro i difetti dei materiali e di fabbricazione come da tabella seguente:

CATEGORIA	PERIODO	NOTES
Parti del telaio	5 anni	Triangolo anteriore + triangolo posteriore, link
Hardware	1 anno	Perni, assi, ecc.
Parti della trasmissione	1 anno	Pulegge, pignoni, catena di trasmissione
Batteria	2 anni	Se conservata per più di 3 mesi, caricare la batteria ogni 3 mesi. La mancata osservanza di questa precauzione può causare danni.
Elettronica	3 anni	Trasmissione, unità di controllo remoto, jumbotron, sensori, caricabatterie
Parti della trasmissione soggette a usura	1 anno	Pulegge, pignoni, catena e cuscinetti
Battery	24 Months	The Powerplay™ Drive will progressively reduce power output to maximize range, as the battery depletes. Range varies depending on several factors, such as assist level, ambient temperature, acceleration, wind resistance, poor maintenance, battery age, hilly and rough terrain and rider weight. If stored for more than 3 months, charge battery every 3 months. Failure to do so may cause damage & void warranty.
Componenti	Come previsto nella garanzia originale del fabbricante	

La garanzia limitata di Rocky Mountain copre contro i difetti di materiale e fabbricazione anche le biciclette utilizzate in precedenza per attività personali e commerciali, come il noleggio (anche presso i bike park), i servizi di corriere, di polizia, di sicurezza e così via. La garanzia limitata si applica per il periodo di garanzia rimanente a partire dalla data di acquisto originale da Rocky Mountain. In questi casi, minuteria, cuscinetti, perni e bronzine sono esclusi dalla nostra politica di garanzia. Per tutti i reclami è necessario lo scontrino originale, la conferma di registrazione della bicicletta o un'altra prova d'acquisto.

Per i modelli di bicicletta dal 2021 in poi, la garanzia limitata originale è trasferibile ai proprietari di seconda mano. Per la validità della garanzia limitata, la registrazione della bicicletta deve essere effettuata online sia dal proprietario originale che dal proprietario di seconda mano. La fattura originale non sarà richiesta al proprietario di seconda mano.

### Per trasferire la garanzia è necessario registrare la bicicletta.

#### Materiale del telaio / tipo di utilizzo

- Fibra di carbonio: 5 anni - Limitata\*
- Alluminio: 5 anni - Limitata\*
- Si rimanda alle limitazioni indicate di seguito

#### Altre coperture in garanzia contro i difetti dei materiali e di fabbricazione

- Rivestimento - vernice e decalcomanie: 1 anno
- Hardware del telaio, sospensioni, perni e bronzine: 1 anno
- \* Le maglie fanno parte del telaio.

[bikes.com/registration](https://bikes.com/registration)

## GARANZIA

### NOTA

#### La garanzia non è valida nei casi seguenti:

- Installazione e utilizzo di componenti, parti o accessori non originariamente previsti o compatibili con la bicicletta o il telaio venduti.
- Acquisto di una bicicletta Rocky Mountain da un rivenditore non autorizzato.
- Acquisto di una bicicletta o di un telaio Rocky Mountain su siti internet di terze parti (come eBay), indipendentemente da quanto indicato nell'inserzione.
- Lo sbiadimento della vernice causato dagli effetti della luce ultravioletta (UV) o dall'esposizione all'esterno non è coperto dalla presente garanzia limitata.
- Rocky Mountain non fornisce alcuna garanzia per eventuali danni causati alla bicicletta durante l'applicazione o la rimozione di qualsiasi pellicola protettiva.
- Graffi o scheggiature della vernice causati da sporcizia, sassi, detriti stradali, trasporto su rack, ecc. non sono coperti dalla presente garanzia limitata.
- I danni al movimento centrale Press-fit causati da manutenzione, parti o materiali inadeguati non sono coperti dalla garanzia limitata Rocky Mountain.

#### Dettagli di cosa non è coperto dalla garanzia:

- A. La normale usura di pneumatici, tubi, freni, cavi del cambio, pastiglie dei freni, cuscinetti, ecc. non è coperta da garanzia. Il rivenditore autorizzato Rocky Mountain informerà il cliente su quali sono queste normali parti soggette a manutenzione.
- B. Danni consequenziali o qualsiasi danno causato da incidenti, uso improprio o abuso.
- C. L'assemblaggio improprio o la mancata manutenzione, la sabbatura, la levigatura, la smerigliatura, la spazzolatura a filo, la limatura, la saldatura, la brasatura, la foratura, l'anodizzazione, la riverniciatura o la cromatura non sono coperti dalla nostra garanzia e possono invalidare la garanzia degli altri componenti.
- D. L'utilizzo della bicicletta su terreni estremamente difficili come quelli che si vedono nei video di mountain bike (piste di trial, rampe, acrobazie, piste di BMX, scale, terrapieni, ecc.) è molto pericoloso e annulla la garanzia descritta nella tabella precedente. È importante notare che la piegatura di componenti, telai, forcelle, manubri, reggisella, pedali, pedivelle e cerchi delle ruote è segno di incidenti o uso improprio.
- E. È esclusa la manodopera per la sostituzione dei componenti.
- F. Rocky Mountain si riserva il diritto di riparare o sostituire a sua discrezione qualsiasi parte considerata validamente coperta da garanzia. Si prega di notare che Rocky Mountain farà tutto il possibile per assicurare la corrispondenza del colore con il componente originale, ma non può garantirla.

#### ESCLUSIONE E LIMITAZIONE DEI DANNI

LA GARANZIA DI ROCKY MOUNTAIN SI LIMITA ALLA RIPARAZIONE O ALLA SOSTITUZIONE DEI PRODOTTI E NON CONCEDE ALCUNA GARANZIA ESPRESSA O IMPLICITA, LEGALE O CONVENZIONALE E DECLINA QUALSIASI GARANZIA IMPLICITA DI COMMERCIALIZZABILITÀ E IDONEITÀ PER SCOPI PARTICOLARI; ROCKY MOUNTAIN NON SARÀ IN NESSUN CASO RESPONSABILE PER DANNI DIRETTI O INDIRETTI, SPECIALI, INCIDENTALI O CONSEQUENZIALI, ANCHE QUALORA ROCKY MOUNTAIN SIA STATA AVVISATA DI TALI DANNI, E LA RESPONSABILITÀ DI ROCKY MOUNTAIN SARÀ LIMITATA A 50,00 DOLLARI.

## DICHIARAZIONE DI CONFORMITÀ

Dichiariamo che le piattaforme dotate di sistemi Powerplay™ sono conformi alle pertinenti norme armonizzate dell'Unione Europea.

Rocky Mountain Instinct Powerplay SL™

Per un elenco completo dei modelli, visitare [www.bikes.com](http://www.bikes.com)

I prodotti sopra descritti soddisfano i requisiti delle seguenti direttive:

- Direttiva Macchine 2006/42/CE
- Direttiva EMC 2014/30/UE
- Direttiva RoHS 2011/65/UE

I prodotti sono stati progettati e validati per soddisfare i requisiti delle seguenti norme:

- EN15194:2017: Cicli elettricamente assistiti – biciclette EPAC
- ISO4210-2:2015: Requisiti di sicurezza per le biciclette
- IEC/EN 62133-2:2017: Accumulatori alcalini e altri accumulatori con elettrolita non acido – Requisiti di sicurezza per accumulatori portatili sigillati e per batterie costituite da essi, destinati all'uso in applicazioni portatili – Parte 1: Sistema al litio
- EN50601-1L2016: Accumulatori al litio per applicazioni su veicoli elettrici leggeri – Parte 1: requisiti generali di sicurezza e metodi di prova.

Io, Pierre-Luc Lapointe, Direttore R&D – Propulsione, sono incaricato di preparare la documentazione tecnica in qualità di rappresentante del produttore Rocky Mountain, Division of Industries RAD inc.

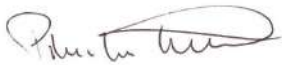

**Pierre-Luc Lapointe, ing.**  
**R&D Director – Propulsion**  
**9095 25th Avenue, St-George, Quebec, Canada**

**Authorized European representative:**



**Carsten Bresser**  
**Managing Director, Bikeaction GmbH**  
**Weiskircher Str. 102, Rodgau, Germany**

### **Produttore e importatore UE**

Rocky Mountain  
Division of Industries RAD inc.  
9095, 25th Avenue  
Saint-Georges, Qc,  
Canada, G6A 1A1

### **Svizzero**

CHRIS Sports AG  
Wittenwilerstrasse 12,  
8355 Aadorf  
vizzero

### **Rappresentante autorizzato in Europa**

Bikeaction GmbH  
Weiskircher Str. 102  
63110 Rodgau  
Germania

### **Norvegia**

Vertical Playground AS  
Ola Setroms Veg 17  
7340 Oppdal  
orvegia

**(EU) 2023/1542 ARTICLE 10 PART A OF ANNEX IV**

Model Name	Rated capacity and capacity fade		Power and power fade <small>*This value is for reference only.</small>				Internal resistance and internal resistance increase <small>*This value is for reference only.</small>		The expected life-time of the battery under the reference conditions for which is has been designed
	Rated capacity (Ah)	Capacity fade (%)	Power (W)		Power fade (%)		Internal resistance (Ω)	Internal resistance increase (%)	Under the cycles (times)
			Power capability		Power capability				
			at 80%	at 20%	at 80%	at 20%			
1972002	14.3	>25	680	581	93	92	>0.143	195	1000
1972011	8.8	>50	676	581	96	95	>0.133	109	500
1974005	4.75	>25	383	328	91	89	>0.330	199	1000
1975006	9.5	>25	731	626	91	90	>0.162	196	1000



**LOVE THE RIDE**

**Development Centre**  
**Centre de développement**  
**Entwicklungszentrum**  
**Centro di Sviluppo**

1225 East Keith Road, Unit #10  
 North Vancouver, BC, Canada, V7J 1J3  
 T. 604-980-9938 F. 604-980-9975

**Head Office**  
**Siège social**  
**Hauptsitz**  
**Sede Centrale**

9095, 25<sup>th</sup> Avenue,  
 St-Georges, QC, Canada, G6A 1A1  
 T. 1-800-663-2512 F. 1-800-570-8356

*Rocky Mountain, its logo and other trade names are registered trademarks.  
 Some technologies on Rocky Mountain products are patented or patent pending.*

*Rocky Mountain, son logo et ses autres noms commerciaux sont des marques déposées.  
 Les produits Rocky Mountain sont munis de technologies brevetées ou en instance de brevet.*

*Rocky Mountain, unser Logo und andere Handelsnamen sind eingetragene Warenzeichen. Einige  
 Technologien der Rocky Mountain Produkte sind patentiert oder zum Patent angemeldet.*

*Rocky Mountain, il suo logo e gli altri nomi commerciali sono marchi registrati.  
 Alcune tecnologie presenti sui prodotti Rocky Mountain sono brevettate o in attesa di brevetto.*